

MINISTRY OF EDUCATION AND SCIENCE OF UKRAINE
NATIONAL AVIATION UNIVERSITY
FACULTY OF ARCHITECTURAL STRUCTURES AND AIRFIELDS
COMPUTER TECHNOLOGIES OF AIRPORT CONSTRUCTION AND
RECONSTRUCTION DEPARTMENT

TO ADMIT TO GUARD

Head of the Department

 O.T. Lapenko

16 10 2023

QUALIFICATION PAPER

(EXPLANATORY NOTE)

SPECIALTY 192 «BUILDING AND CIVIL ENGINEERING»

Educational and professional program: «Industrial and civil engineering»

Theme: Trade pavilion in Kyiv

Performed by: st., 406Ba gr., Pyatenko Maksim Tarasovich

Qualification Paper Advisor: doc. of tech. sc., prof., Barabash Maria 

Design rule check:  PhD, docent, Oleksandr Rodchenko

Kyiv 2023

МІНІСТЕРСТВО ОСВІТИ І НАУКИ УКРАЇНИ
НАЦІОНАЛЬНИЙ АВІАЦІЙНИЙ УНІВЕРСИТЕТ
ФАКУЛЬТЕТ НАЗЕМНИХ СПОРУД І АЕРОДРОМІВ
КАФЕДРА КОМП'ЮТЕРНИХ ТЕХНОЛОГІЙ БУДІВНИЦТВА ТА
РЕКОНСТРУКЦІЇ АЕРОПОРТІВ

ДОНУСТИТИ ДО ЗАХИСТУ

Завідувач випускової кафедри

 І. Лашенко

«16» вересня 2023 р.

КВАЛІФІКАЦІЙНА РОБОТА

(ПОЯСНЮВАЛЬНА ЗАПИСКА)

ВИПУСКНИКА ОСВІТЬНОГО СТУПЕНЯ БАКАЛАВР

ЗА СПЕЦІАЛЬНІСТЮ 192 «БУДІВНИЦТВО ТА ЦИВІЛЬНА ІНЖЕНЕРІЯ»

Освітньо-професійна програма: «Промислове і цивільне будівництво»

Тема: Торговельний павільйон в м. Київ

Виконавець: студент групи 406Ба, П'ятенко Максим Тарасович

(студент, група, прізвище, ім'я, по батькові)

Керівник: д.т.н., професор, Барабаш Марія Сергіївна

(науковий ступінь, вчене звання, прізвище, ім'я, по батькові)

Нормоконтролер:

(підпис)

Родченко О.В.

(ПІБ)

Київ 2023

НАЦІОНАЛЬНИЙ АВАІАЦІЙНИЙ УНІВЕРСИТЕТ

Факультет наземних споруд і аеродромів

Кафедра імені Юрія Івановича Бабанітца та реконструкції аеродромів

Спеціальність: 192 «Будівництво та цивільна інженерія»

Освітньо-професійна програма: «Промислове і цивільне будівництво»

ЗАТВЕРДЖУЮ

Завідувач випускової кафедри

Олександр Лапченко
Олександр ЛАПЧЕНКО

« 11 » травня 2023 р.

ЗАВДАННЯ

на виконання кваліфікаційної роботи

Пятенко Максим Тарасович

1. Тема роботи «Торговельний павільйон у м. Київ»

затверджена наказом ректора від «11» травня 2023р. № 681/ст.

2. Термін виконання роботи: з 29 травня 2023р. по 30 червня 2023р.

3. Вихідні дані роботи: Запроектувати будівлю торговельного павільйону. Основні конструктивні рішення: фундаменти стрічкові монолітні залізобетонні, стіни цегляні товщиною 510 мм; колони, перекриття, покриття – монолітний залізобетонний каркас; сходові марші – залізобетонні; перегородки з гіпсобетонних блоків (400х400х100 мм та 400х400х120 мм).

4. Зміст пояснювальної записки:

Вступ.....

4.1. Інженерні вишукування.....

4.2. Архітектурний розділ.....

4.3. Розрахунково-конструктивний розділ.....





4.4. Технологія будівництва.....

4.5. Охорона праці та навколишнього середовища.....

Література.....

5. Перелік обов'язкового ілюстративного матеріалу: таблиці, рисунки, діаграми, графіки, схеми.

6. Календарний план-графік

| № з/п | Завдання | Термін виконання | Підпис керівника |
|-------|---|------------------|--|
| 1. | Виконати оцінку кліматично-геологічних чинників регіону будівництва, що мають ключовий вплив на вибір конструктивних рішень під час проєктування будівлі. | Травень 2023р. |  |
| 2. | Розробити об'ємно-планувальні рішення будівлі, архітектурно-конструктивні рішення, основні будівельні конструкції. | Травень 2023р. |  |
| 3. | Виконати розрахунок фундаментів та покрівлі з використанням BIM-технологій. | Травень 2023р. |  |
| 4. | Визначити об'єми основних будівельних робіт та розробити технологічну карту на виконання бетонування та влаштування риштування. Виконати підбір монтажного крану. | Червень 2023р. |  |
| 5. | Розробити заходи з контролю викидів в атмосферу шкідливих речовин при виконанні основних будівельно-монтажних робіт та зазначити рекомендації щодо формування екологічної мережі. | Червень 2023р. |  |

7. Дата видачі завдання: « 11 » травня 2023 р.

Керівник кваліфікаційної роботи:

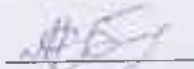

Барабаш М.С.

Завдання прийняв до виконання:

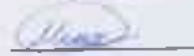

П'ятенко М.Т.

CONTENT

| | |
|---|-----|
| Introduction | ___ |
| 1. Engineering surveys of physical and geographical conditions of the construction area (Kyiv) | ___ |
| 1.1. General information | ___ |
| 1.2. Geographical location | ___ |
| 1.3. Hydrological features | ___ |
| 1.4. Climatic conditions | ___ |
| 1.5. Soil cover..... | ___ |
| 2. Architectural part | ___ |
| 2.1. Space planning solution | ___ |
| 2.2. Constructive solution | ___ |
| 2.3. Key decisions of the master plan | ___ |
| 2.4. Thermal engineering calculation of enclosing structures | ___ |
| 2.5. Engineering systems | ___ |
| 2.6. Fire prevention measures | ___ |
| 3. Calculation and design part | ___ |
| 3.1. Calculation of foundations | ___ |
| 3.2. Calculation of coverage | ___ |
| 3.3. Selection of reinforcement | ___ |
| 4. Construction technology | ___ |
| 4.1. Work technology | ___ |
| 4.2. Methods of work | ___ |
| 4.3. Quality control | ___ |
| 4.4. Safety precautions | ___ |
| 4.5. Installation of hinged ventilated facade..... | ___ |

5. Labour and environmental protection_____

 5.1. Atmospheric air condition....._____

 5.2. Formation of an ecological network....._____

References_____

Introduction

The diploma project aims to provide comfortable working conditions for trade workers and the administration of small businesses, formally included in the city limits of Kiev. Initially, the task was to design a small compact building for retail and office space, which will meet modern requirements for environmental friendliness, microclimate. The construction should be economically sound. In the current economic conditions (since 2018) there is a tendency to enlarge office buildings, to merge them with retail premises, to build powerful retail-office and retail-entertainment complexes. Naturally, for the construction of such a building to be economically feasible, it should be located in the business center of the city, with a large number of active population. In this case the building does not have such conditions, as it is located in a small municipality on the periphery of Kiev. That is why it was decided to refuse a multi-storey office center and try to do with a small volume of construction, based on the size of the population of the settlement.

A detailed plan of the development area is urban planning documentation that determines the planning organization and development of the territory. A detailed plan within a settlement specifies the provisions of the master plan of the settlement and determines the planning organization and development of a part of the territory.

A detailed plan is developed to determine the planning organization and functional purpose, spatial composition and parameters of development, as well as landscape organization of a block, microdistrict, other part of the territory of a settlement intended for complex development or reconstruction.

The detailed plan of the territory development determines:

- principles of planning and spatial organization of development;
- red lines and lines of development regulation;

- functional purpose, regime and parameters of development of one or more land plots, distribution of territories in accordance with building codes, state standards and regulations;

- urban planning conditions and restrictions;

- sequence and scope of engineering preparation of the territory;

- system of engineering networks;

- the procedure for organizing transport and pedestrian traffic;

- the procedure for comprehensive landscaping and gardening;

- boundaries of coastal protection zones and beach areas of water bodies.



1. Engineering surveys of physical and geographical conditions of the construction area (Kyiv)

1.1. General information

With a population of over 2.936 million people, Kyiv is one of the ten largest cities in Europe, and in terms of population and area of 835.6 km², it is second only to such European cities as London, Rome and Berlin.

Geographical coordinates: north latitude - 50° 26'; east longitude - 30° 34'; average height above sea level - 105 m.

The city of Kyiv is located in the center of Eastern Europe on both banks of the Dnipro River, in its middle reaches, below the confluence of the left tributary, the Desna River. The peculiarity and diversity of Kyiv's natural conditions are related to its location on the border of physical and geographical zones: forest-steppe and mixed forests. The northern part of the city is located on the Polissia lowland, the southwestern (right-bank) part is on the Prydniprovskia upland, and the southeastern (left-bank) part is on the Prydniprovskia lowland.

The surface of the right-bank part of the city is an elevated plateau-like plain, dissected by ravines and gullies, valleys of small rivers, and the left-bank part is a lowland plain. The characteristic relief forms of the right bank are the mountain peaks, in particular, Pecherska (its height is 196 m above sea level), Starokyivska (188 m), Batyieva (176 m), Khorevytsia (174 m), Bagrynova (170 m), Shchekavytsia, Zamkova, Zvirynetska, Chorna, Cherepanova, and Lysa. The most famous ravines: Babyn, Khreshchatyi, Smorodynskyi, Kmitiv, Protasiv, Tsymbaliv, and others. The lowest parts of the city correspond to the water level in the Dnipro River - about 92 meters above sea level.

Geologically, Kyiv and its surrounding areas are located at the junction of two regional structures: the northeastern slope of the Ukrainian crystalline shield and the southwestern side of the Dnipro-Donetsk depression. The boundary between them is the Dnipro fault zone of northwestern strike. As a result, Kyiv is

located in a fairly calm tectonic zone. The soil cover of Kyiv is very diverse, given the variety of natural conditions. The northern outskirts of the city, which tend to Polissia, are characterized by sod-podzolic soils formed mainly under coniferous forests. The right-bank highlands of the city are dominated by black soils, which are common to most of Ukraine. They were formed mainly on very peculiar loose, well-ventilated and relatively dry loams - loess. In Kyiv's natural forest parks, dark gray forest soils formed under the canopy of broadleaf forests are common.

The city of Kyiv is rich in water: there are significant reserves of underground water; in addition, there are a large number of surface water bodies: rivers, lakes, and ponds. In total, water bodies in the city cover 6.7 thousand hectares, or 8.0% of the territory.

The hydrographic network of the district is represented by the Dnipro River, rivers of its basin (Desna, Lybid, Syrets, Nyvka, Gorenka, Vita, and Pliakhovyi), lakes, swamps, artificial ponds, and canals.

The Dnipro River and its valley have a decisive influence on the natural conditions of Kyiv and the location of elements of its residential and industrial agglomeration.

The regime of all rivers is characterized by a pronounced spring flood, low summer low water marks, and slightly elevated levels in the fall due to seasonal rains. The rivers are fed by mixed sources, with groundwater predominating.

The city of Kyiv is characterized by a fairly comfortable, temperate continental climate with warm summers and mild winters, and optimal humidity.

The climate of Kyiv is moderately continental, with rather mild winters and warm summers. Kyiv's climate is significantly influenced by the Dnipro River, which is stretched in a submeridional direction within the city. A large movable water area contributes to the formation of breeze air transport: during the day, the temperature difference between water and land creates flows of fresh, moist air into the city. The city is dominated by anticyclonic activity throughout the year, which is characterized by fairly stable, low-cloud weather. The average annual air

temperature is +8.9 - +11.90 °C. The global climate change observed on the globe could not bypass Kyiv. Moreover, the city itself has a significant impact on the climate conditions - heat dissipation from heating mains, buildings, thermal power plants, etc. As a result, the air temperature in the city is higher than in its suburbs. The increase in air temperature in Kyiv in recent decades has been higher than the global average. The average annual rainfall is 600-700 mm. The prevailing wind direction is westerly in summer and northwesterly in winter.

The total area of Kyiv is 835.6 km². The built-up area of the city is 37.0 thousand hectares or 44.3%. By functional use, the territory of Kyiv is divided into the following zones: - rural (urban and rural development); - industrial; - recreational (forests, parks, squares, public green spaces, nature protection facilities, water bodies). Each of the functional zones is characterized by its own specific features, purpose and impact on the environment.

The urban zone is characterized by high-rise buildings in the central right-bank part of the city, in the new residential areas of Obolon, Vynohradar, Teremky, etc., and on the Left Bank - Troyeschyna and Kharkivskyi residential areas, as well as private buildings located mainly on the outskirts of the city along its perimeter. The negative impact of this zone on the environment can be assessed as medium.

The industrial zone consists of industrial and motor transport enterprises. They are grouped into industrial hubs and zones within the Kyiv metropolitan area: Podilsko-Obolonsky, Shulyavka, Nyzhnyolybidsky, Darnytsky, and Telbinsky. The negative impact of this zone on the environment is assessed as severe.

1.2. Geographical location

The city of Kyiv is located in the center of Eastern Europe and enjoys a favorable geographical location and natural conditions. Kyiv lies on both banks of the Dnipro River, below the confluence of the left tributary Desna. The northern part of the city is located on the Polissia Lowland, the southwestern (right bank) part on the Prydniprovia Upland, and the southeastern (left bank) part on the

Prydniprovia Lowland. Relative elevations on the right bank reach 100-105 meters. The left-bank part of Kyiv is a stepped, terraced, poorly dissected plain with a relative elevation of 35 m.

The area of Kyiv within the administrative boundaries is 83.6 thousand hectares (836 square kilometers); including the built-up area - 33.8 thousand hectares or 40.4%, of which residential land occupies 6.2 thousand hectares. Industrial facilities occupy 6.0 thousand hectares, public buildings - 6.7 thousand hectares, streets, squares, embankments - 5.0 thousand hectares, and transport facilities - 2.2 thousand hectares.

More than half of the city's territory is occupied by forests, public green spaces and water bodies. The basis of the city's green space system is a unique water-green diameter of 30 km long and 1.5-5 km wide, which includes the Dnipro water area with islands, coastal parks and Lugopark.

Kyiv has rich recreational resources. The city is surrounded by an almost continuous ring of forests. Coniferous and broadleaf forests are located in the north, northwest, and west (mixed forest zone), and broadleaf forests in the forest-steppe zone. There are significant natural and artificial forests and parks within the city. Per capita, the area allocated for green spaces is more than 200 square meters.

Kyiv's favorable natural conditions have led to the formation and development of two climate resorts: Pushcha-Vodytsia and Koncha-Zaspa (a resort of national importance). In total, there are 37 sanatoriums and health resorts with treatment, rest homes and boarding houses, and 27 sanatoriums and preventive care facilities in the city.

There are 41 objects of nature reserve fund in the city, including 14 of national importance.

1.3. Hydrological features

The city of Kyiv is rich in water: there are significant groundwater reserves; in addition, there is a large number of surface water bodies: rivers, lakes, and

ponds. In total, water bodies in the city occupy 6.7 thousand hectares, or 8.0% of the territory.

There are 422 reservoirs of various types in the city of Kyiv, including 44 artificial reservoirs. These include lakes, pond systems, small rivers, and the Dnipro River, which forms the Kaniv Reservoir below Kyiv. Each body of water has its own hydrological characteristics and anthropogenic load of varying degrees of intensity.

The length of rivers in the city is 104.28 km.

Within the city limits, the Dnipro is 400-600 meters wide and 6-12 meters deep. In shallow waters, the width is 800-1000 meters and the depth is 4-5 meters. The ice cover lasts from late November to early March. Sandy beaches stretch along the banks of the Dnipro (the best are on Trukhaniv Island). The Dnipro forms numerous tributaries (Rusanivka, Desenka), bays (Matviyivska, Havan, Staryk), and floodplain lakes (Radunka, Telbyn). The Lybid, Syrets, Vita (right tributaries of the Dnipro), Horenka, and Nyvka (tributary of the Irpin) also flow through Kyiv. Large sections of the Lybid have been taken into collectors. Some rivers, such as the Syrets and Nyvka, form lakes. The outlines of floodplain lakes increase during floods. The water surface of the lakes does not exceed 3-5 hectares. The ice thickness in winter is about 60 cm. The highest temperature of the lakes is in July.

1.4. Climatic conditions

According to the physical and geographical zoning, the design area is located in subzone II-B1 (Polissya) of climatic zone II-B, which is favorable for all types of construction. The design temperature for the building envelope is -21°C.

According to the urban planning zoning based on natural, geographical and engineering conditions, the design area, in general, belongs to the areas with favorable urban planning conditions.

According to meteorological stations, the climate of the region is temperate continental with moderately hot summers and moderately cold winters. The average annual air temperature is $+6.8^{\circ}\text{C}$, the average annual temperature of the coldest month - January - is -5.9°C , and the warmest month is $+19.1^{\circ}\text{C}$. The lowest absolute temperature of -36°C and the highest of $+39^{\circ}\text{C}$ indicate possible cases of crop freezing in winters with little snow.

The average annual precipitation is 602 mm, with the bulk of it occurring during the warm season.

The average dates when the average daily air temperature crosses 0°C (early spring - late autumn), 5°C (beginning and end of the growing season), 10°C (active growing season) and 15°C (beginning and end of summer).

The growing season lasts 207 days.

On average, the first frosts occur in mid-October, and the last frosts occur at the end of the second decade of April. The duration of the frost-free period in days is: the average is 180, the minimum is 146, and the maximum is 215.

The timing of snow cover formation and melting is largely dependent on weather conditions and can vary greatly from year to year and differ from long-term averages.

On average, stable snow cover is formed in the early third decade of December. The average number of days with snow cover is 102.

The lack of stable snow cover in some winters is due to prolonged and intense thaws.

The first snow cover is usually small in height, but with the establishment of a stable cover, its height begins to increase slowly. At the end of November, the snow cover averages 2 cm, at the end of December it reaches 8 cm, in January - 15 cm, and in February - 20 cm.

The average long-term height of the highest ten-day snow cover over the winter is 8 cm.

From the third ten-day period of February, the snow cover thickness slowly decreases. In the first ten-day period of April, snow melts intensively and by the end of the ten-day period it remains on less than 50% of the territory.

The density of the snow cover largely depends on the weather regime and varies from 250 to 480 gk/km³. The water content in the snow cover varies from 9 to 16 mm during the cold period, reaching a maximum at the beginning of spring melt. The average of the largest winter water reserves is 37 mm.

The average long-term precipitation is 657 mm. About 65% of annual precipitation falls during the warm season (April-October).

The annual variation of the daily maximum clearly shows an increase in precipitation in the summer season due to the prevalence of storm precipitation at this time. The average daily maximum precipitation is 23-25 mm. This is significantly higher than the daily maximum precipitation in other seasons.

The largest number of days with precipitation and the longest duration of precipitation are observed in winter. However, in winter, with a long duration of precipitation, the amount of precipitation is relatively small. During this period, low-intensity precipitation and prolonged drizzle prevail. In some years, the duration of precipitation can exceed 300 hours per month.

The area under consideration is dominated by westerly and northwesterly winds.

In the warm season, northwest winds prevail, and in the cold season, west and southeast winds.

During the movement of atmospheric fronts, wind speeds can increase up to 30 m/s.

1.5. Soil cover

The territory of the region has a peculiar geological structure and consists of two main heterogeneous and different age structural elements. The southwestern part is confined to the Ukrainian Shield. Precambrian crystalline rocks are overlain

by a relatively thin cover of sedimentary rocks, and in the river valleys they are exposed to the surface. The northern and north-eastern parts of the region belong to the Dnipro-Donetsk depression, where the crystalline basement is deeply buried under sedimentary strata of Paleozoic, Mesozoic and Cenozoic rocks.

The surface of the Precambrian basement in the southern part of the region is uneven. Denudation processes in the conditions of the long continental development of the shield caused intensive destruction. The surface of the denuded basement is complicated by widespread erosion depressions alternating with elevated areas of tectonic origin.

On the north-eastern slope of the Ukrainian Shield, at depths of more than 500 m below the Dnipro River level, there is a thickness of sedimentary rocks of different ages.

Kyiv region is located within three orographic regions. The right bank part has a general slope to the northeast and east. On the Left Bank, the surface slopes to the west and southwest. The most elevated is the southwestern part of the region, where the heights within the Tarashchansky district reach 273 meters. In the northern part, they are 190 m, and on the Left Bank they range from 90 to 140 m.

On the Right Bank, especially in the Dnipro strip, which is densely cut by a gully and gully network, the depth of the surface dissection reaches 100...110 m, gradually decreasing to the northwest and west. The surface of the Prydniprovskya Upland within the Kyiv region is dissected by a dense network of river valleys and gullies.

In the Polissya Lowland, the depth of the dissection is much less. The wide valleys of the Dnipro, Prypiat, Uzh, Teteriv, Zdvyzh, and Irpin play an important role in the surface structure. sandbanks, hills, and ridges over 20...25 m high are common on the interfluves and wide terraced surfaces in the river valleys.

The Prydniprovska lowland is a typical terraced plain with rather weak fluctuations in absolute and relative elevations. The surface of the Left Bank is not well dissected.

There are few minerals within the region. Kyiv region has significant reserves of peat, quartz sands, and other building materials.

The climate of the Kyiv region is intermediate between that of the western and eastern regions. The absence of high mountain rises facilitates the free movement of air of various origins, which causes significant variability in weather processes in certain seasons.

The surface of the Kyiv region is characterized by a developed hydrographic network (177 rivers over 10 km long). The rivers are part of the Dnipro and Southern Bug basins. Groundwater is widely used to supply water to settlements. The region as a whole is insufficiently provided with local water resources.

Being located within two natural zones, the territory of the region has a diverse soil and vegetation cover. The northern part of the region is characterized by sod-podzolic soils, and in the river valleys - sod-gley, meadow and marsh soils, large areas of coniferous and mixed forests, large areas of grass and cereal meadows and wetlands. The forest-steppe part of the Kyiv region is characterized by a complex intermixture of gray forest soils formed under broadleaf forests and black soils formed under meadow steppes.

Main types of landscapes in the region:

- Zander plains;
- Moraine hills;
- Glacial valleys;
- Wetlands;
- River terraces;
- Dissected forest plains and uplands.

2. Architectural part

2.1. Space planning solution

The premises of the building can be divided into working, service and auxiliary rooms. Working spaces include retail and office space. Servicing include rooms lobbies, toilets. Auxiliary include technical rooms of the basement, vestibules, corridors, rooms designed to accommodate the engineering equipment of the building, storage rooms.

The basement contains storage rooms for storing goods. Entrance to the storage rooms is from the west facade. Entrance to the corridor is possible from the main staircase, as well as from the street side staircase. Ceiling height in the basement is assumed 2.0 m.

On the first floor is the central entrance. Through the entire building on the longitudinal axis runs a central corridor. It connects four office rooms, a hall, WC, foyer, main staircase and emergency exit. The ceiling height on the first floor is 3.0 m.

On the second floor are office rooms. As on the first floor, a central corridor connects the reception areas and offices. An extensive conference room and toilet facilities are provided.

The third floor is a semi-detached room.

2.2. Constructive solution

Land allotted for the construction of the building is located in Kiev and is free from development. The topography of the site is calm, absolute marks within the allotted area ranging from 8.80 to 8.95.

The building is two-story, with a pitched roof. The size of the plan is 50.4 × 15 m. The premises are designed in accordance with modern requirements, which is reflected in the layout and size of the premises. The constructive diagram of the building - monolithic reinforced concrete frame with load-bearing columns on the

outer and inner sides of the building, and non-bearing internal plaster-concrete walls. Rigidity is provided by the closed monolithic walls of the stairwells and end walls on the side facades. Height of the top of the ridge +11.340 m. Facade cladding - stained glass windows of three layers of tinted glass. Ventilated facade of ceramic granite with 100 mm basalt wool insulation.

The foundation of the building is made of monolithic reinforced concrete, in the base of the foundation there is a cement-sand foundation with a waterproofing carpet on it. The load of the bearing walls is perceived and transmitted to the ground by the foundation pads.

Interfloor ceilings are made of monolithic reinforced concrete 100 mm thick. The toilets shall be waterproofed with several layers of waterproofing mastic.

Partitions between the rooms shall be made of plaster-concrete blocks (400x400x100; 400x400x120). On the first floor between the corridor and the sales rooms the partition wall and the door are made of double-glazed windows. Glass windows are also used for the stained-glass windows and entrance doors of the first floor.

Staircase of reinforced concrete steps, platforms steps of precast concrete slabs, exterior steel staircase with stone slabs finish.

The roof is designed gable. As the roofing material used soft tile. Wooden rafters with purlins are arranged so that people can move around in the attic.

The building is located in the vicinity of busy streets, which makes its adjustments in the construction plan and technology of erection.

In the surrounding area is designed parking for employees of the administration, asphalt paths on the perimeter of the building and a small recreation area in front of the main entrance. The building is fenced metal wrought iron lattice around the perimeter.

2.3. Key decisions of the master plan

The project provides for the main entrance to the office from the side of Vyborgskaya Street. On the west side of the building provides an emergency exit. Tree survey has not been carried out due to the lack of green areas. In order to remove garbage, the customer concludes a contract with an utilities company for garbage removal from an additional garbage container located on the container site of the allotted area.

Main indicators:

Area of the territory - 4260 m²

Building area - 809 m²

The area of roads and sidewalks - 2030 m²

The area of the used area - 870 m²

Greening area - 1350 m²

Building coefficient - 0,19

Land use coefficient - 0,99

Planting coefficient - 0,32

Territory 4260 m²

The project provides for a site with a surface of paving slabs (paving stones). Plan for the organization of the relief of the site is made with the natural terrain, drainage of surface water and permissible slopes for the movement of transport and pedestrians. The area is landscaped. Currently solved the issues of storm water discharge into the storm sewer, there is outdoor lighting.

2.4. Thermal engineering calculation of enclosing structures

Thermal engineering calculations are performed under the assumption of stationary (constant) conditions of heat transfer in the cold season (Table 2.1). Most of the processes occurring in nature are non-stationary (annual and daily fluctuations in outdoor air temperature, changes in heat transfer from heating

devices, changes in air exchange in the room during the operation of ventilation systems, the behavior of people seeking to create comfortable microclimate parameters).

Characteristics of the object.

Table 2.1. Characteristics of heat engineering calculation

| | |
|--|---------------------------|
| Construction area | m. Kyiv |
| Purpose of the object | Public building, 2 floors |
| Estimated temperature of the coldest five-day period | -20 |
| Estimated internal air temperature | 20 |
| Heat transfer coefficient according to DBN | 8,7 |
| Difference between the internal air temperature | |
| Walls (external, internal) | 4 |
| Covering and ceilings of attics | 3 |
| Ceilings over passages and basements | 2 |
| Type of heater | Convector |
| t_{ex} | 95 |
| $t_{вмz}$ | 85 |
| $R_{q,min}$ walls | 3,3 |
| $R_{q,min}$ flooring | 3,75 |
| $R_{q,min}$ roofing | 4,95 |

If the structure consists of several layers, the resistance is calculated for each layer and then summed.

The resistance to heat transfer is the main indicator of the external structure. Its value must exceed the standard value. When performing a thermal engineering

calculation of the building envelope, we must determine the economically justified composition of the walls and roof (Table 2.2).

Table 2.2. Characteristics of the outer wall

| Material | Density of the material in the dry state ρ_0 , kg/m^3 | Thermal conductivity coefficient λ_p , $Wt/(m \cdot K)$ | Layer thickness δ_i , m |
|--|--|--|-------------------------------------|
| Gypsum sheets, facing (dry plaster) | 800 | 0,21 | 0,012 |
| Ordinary clay brick on cement-sand mortar | 1800 | 0,81 | 0,510 |
| Thermal insulation from | 70 | 0,034 | 0,100 |

The façade is insulated with 100 mm thick mineral wool boards, followed by decorative plastering and painting of the façade.

The calculation is carried out for temperature zone I, according to DBN B.2.6-31:2006 "Thermal insulation of buildings".

Thermal resistance value of the building envelope (formula I.1, DBN B.2.6-31:2006):

$$R_{\Sigma} = \frac{1}{\alpha_B} + \sum_{i=1}^4 \frac{\delta_i}{\lambda_{ip}} + \frac{1}{\alpha_s} = \frac{1}{\alpha_B} + \frac{\delta_1}{\lambda_{1p}} + \frac{\delta_2}{\lambda_{2p}} + \frac{\delta_3}{\lambda_{3p}} + \frac{1}{\alpha_s}.$$

(2.1)

As a result of the calculation, the following condition must be met:

$$R_{\Sigma np} \geq R_q \max.$$

$$R_{nn} = 3,3 \text{ (} m^2K/Wt \text{),}$$

$$\frac{1}{8,7} + \frac{0,012}{0,21} + \frac{0,510}{0,81} + \frac{0,1}{0,034} + \frac{1}{23} \geq 3,3,$$

$$R_0 = 3,8 (m^2K/Wt).$$

Thus, the thermal resistance condition is fulfilled, since $3,8 \geq 3,3$.

According to the thermal engineering calculation of the outer wall, we assume a brick wall thickness of 510 mm with external insulation with 100 mm mineral wool boards, i.e. the wall thickness is 610 mm.

2.5. Engineering systems

The construction site of the administrative and office complex is located in the quarter of the existing development, which has engineering networks and facilities, so the water supply is carried out from the water supply network of the city. The building is designed with a system of cold domestic and drinking water supply for domestic and drinking needs.

The water supply system of the building consists of the following main elements: water meter input, distribution main, standpipes and appliance connections, water intake and control valves, fire protection system.

The inlet, in turn, consists of the following elements:

- the underground pipeline to the water-metering node;
- water meter station with the connection to the input of the underground water supply system, located in the basement of the building with the placement of the shut-off valve.

Internal networks of cold water are made of galvanized steel pipes. Shut-off valves are installed at the base of risers, on the branches.

The building is designed for domestic sewage, which is used for the disposal of domestic and fecal water.

Pipelines internal and courtyard sewage designed gravity.

Internal sewage networks are made of cast iron pipes $\varnothing 50$ and $\varnothing 100$ mm.

The layout of the internal drainage system includes:

- the drainage pipes connecting the sanitary appliances to the risers;

- risers running through all floors of the house;
- outlets through which wastewater from the risers flows via an outlet pipe to the city sewer system.

For rainwater runoff, galvanized iron downspouts are provided in the corners of the building. Around the building on the blind area there is a drainage gutter, through which the water flows into the underground channel, which leads to the sewer manhole in the roadway.

Heating, as well as hot water supply is centralized. Heating of the building is carried out from external heating networks with the parameters of the coolant:

$$T_P = 95 \text{ }^{\circ}\text{C}, T_T = 70 \text{ }^{\circ}\text{C}.$$

Heating networks are designed of steel pipes, hot water supply networks of steel galvanized water and gas pipes. Hot water supply, centralized with circulation at the inlet. The inputs of the hot and circulating are laid together with the heating pipes in the channel heating network. Anticorrosive protection of pipelines adopted four layers of organosilicate paint type OS -51-03 with a curing agent of natural drying. Two independent heating system risers are designed. Each riser of the heating system is accepted as two-pipe with the flow of the coolant. Insulation of the pipeline heating system consists of mineral wool products $s = 30 \text{ mm}$ with a subsequent coating of roofing felt and glass wool. The slope of the pipelines is accepted $i = 0,003$. Convectors M140-AO* (lightweight) are accepted for installation as heating devices.

On the supply lines to the heating devices are installed double-adjustment cocks, air removal from the heating system is carried out through the air venting cocks of convectors installed in the upper plugs of the heating device. Uninsulated places of pipelines and heating units are painted with oil paint (on site or in the factory) in 2 times. Gaskets between convector sections are made of 2 mm thick paronite.

The building is designed as a duct system of natural ventilation, its advantage is the simplicity of installation, economic operation and quietness. It is

carried out naturally through brick ducts in the internal and external walls of the building.

The air exchange is calculated in the volume of 50 m³/h per 1 m² of area.

Power supply is performed from the city substation with two sections of power supply by two cables - the main and the spare brand AAB 2L-1000, section 3h50h1h25. Electric switchboard is located in the basement. The voltage of low-frequency network 380/220 V.

Cables lie in the ground in a reinforced concrete trench at a depth of 0.7 m from the level (level marking) of the ground surface of the area. When crossing each other, other communication lines and street passages, cables are laid in asbestos-cement pipes with a diameter of 100 mm.

2.6. Fire prevention measures

The development of a fire in buildings and structures is significantly influenced by the ability of individual building elements to resist the effects of heat, i.e. their fire resistance.

Fire resistance is the ability of building elements and structures to retain their load-bearing capacity, as well as to resist heating to a critical temperature, the formation of through cracks and the spread of fire. The fire resistance of structures and building elements is characterized by the fire resistance limit.

The fire resistance limit is the time (in hours) from the beginning of the fire standard test of samples to the occurrence of one of the limit states of elements and structures (loss of load-bearing and heat-insulating capacity, density). Fire resistance limits and maximum fire spread limits are determined by testing in special furnaces under the appropriate load.

Fire spread limit is the maximum size of damage, cm, which is considered to be charring or burning of the material, which is determined visually, as well as by melting of thermoplastic materials.

Fire barriers. When designing and constructing industrial enterprises, measures are provided to prevent the spread of fire by:

- dividing the building by fireproof ceilings into fire compartments;
- dividing the building into sections with fire partitions;
- installation of fire barriers to limit the spread of fire on structures, combustible materials (ridges, sides, canopies, belts);
- installation of fire doors and gates;
- fire breaks between buildings.

A fire barrier is a structure in the form of a wall, partitions, ceilings or a three-dimensional element of a building designed to prevent the spread of fire in adjacent premises within a normalized time. There are a number of requirements for fire barriers. Fire walls must be supported by foundations and foundation beams, be installed to the full height of the building, and cross all floors and structures. They must be at least 60 cm higher than the roof if at least one of the attic elements is made of combustible materials and 30 cm higher if the attic elements are made of hard-to-combust materials (except for the roof). Fire walls may not rise above the roof if all elements of the attic, except for the roof, are made of non-combustible materials. Ventilation and smoke ducts may be installed in fire walls so that the fire resistance limit of the fire wall on each side of the duct is not less than 2.5 hours.

To divide the building into fire compartments, fire zones are allowed instead of fire walls, which are made in the form of an insert across the entire width and height of the building. Insertion is a part of the building volume formed by fire walls (minimum fire resistance limit is 0.75 hours). The width of the zone is at least 12 meters. Combustibles are not allowed to be stored within the zone. Vertical diaphragms and drainage water curtains are provided on the boundaries of the zone with fire compartments. Within the zone, fire escapes are placed on the roof, and doors or gates are placed in the outer walls of the zone.

Openings in fire walls, partitions and ceilings must be equipped with protective devices (fire doors, fireproof doors, fireproof valves, water curtains) against the spread of fire and combustion products. It is not allowed to install any devices that prevent the normal closing of fire and smoke protection doors, as well as to remove devices for their self-closing. If fire barriers (walls, partitions, ceilings, barrier structures) are crossed by various communications, the gaps (openings) formed between these structures and communications shall be tightly sealed with non-combustible material that provides the fire resistance and smoke and gas tightness required by the building codes for these barriers.

When drawing up master plans for enterprises, it is important to ensure appropriate distances from the boundaries of enterprises to other enterprises and buildings from a fire safety perspective. Fire distances between buildings should prevent the neighboring building from catching fire during the time it takes to activate fire extinguishing equipment.

To protect structures made of metal, wood, and polymers, appropriate substances are used (plaster, special paints, varnishes, and coatings). Reducing the flammability of polymeric materials is achieved by introducing fillers, flame retardants, and applying fire retardant coatings. Chalk, kaolin, graphite, vermiculite, perlite, expanded clay are used as fillers. Flame retardants protect wood and polymers. When heated, they release non-combustible substances, prevent wood decomposition and the release of combustible gases.

When mixed with polymers, they form a homogeneous mixture. After impregnation of wooden structures, fabrics and other combustible materials with flame retardants, a contractor must draw up a report on the work performed. After the expiration of the impregnation period and in case of loss or deterioration of fire protection properties, the treatment (impregnation) should be repeated. The condition of the fire protection treatment should be checked at least once a year and an inspection report should be drawn up.

3. Calculation and design part

3.1. Calculation of foundations

Table 3.1. Characteristics of the engineering and geological elements

| № | Ground name | Natural humidity | Humidity at the yield point | Humidity at the rolling border | Soil density | Soil particle density | Angle of the inner thorn | Clutch | Filtration coefficient | Coefficient of internal friction |
|---|---|------------------|-----------------------------|--------------------------------|-------------------------------|---------------------------------|---------------------------|-------------------|------------------------|----------------------------------|
| | | W | W_l | W_p | ρ , kN/m ³ | ρ_s , kN/m ³ | φ_{II} , degr. | c_{II} , kPa | k_0 , sm/s | m_0 , kPa ⁻¹ |
| 1 | Bulk soil, capacity 1,60m | 0,28 | 0,36 | 0,22 | 16,2 | 26,6 | 45 | 5 | $5,2 \cdot 10^{-7}$ | $4 \cdot 10^{-5}$ |
| 2 | Coarse sand, capacity 1,4m | 0,08 | - | - | 19,2 | 26,6 | 40 | - | $4,0 \cdot 10^{-2}$ | $5 \cdot 10^{-5}$ |
| 3 | Sandy sandy loam, brown- gray, power 4,8m | 0,23 | 0,25 | 0,18 | 18,2 | 26,5 | 21 | 4 | $2,1 \cdot 10^{-5}$ | $18 \cdot 10^{-5}$ |
| 4 | Loam dusty, ribbon gray, power 5,4m | 0,456 | 0,50 | 0,35 | 17,5 | 26,6 | 6 | 4 | $1,0 \cdot 10^{-7}$ | $59 \cdot 10^{-5}$ |

Determining the depth of the foundation

Normative depth of ground frost penetration:

$$d_{fn} = d_o \sqrt{M_t};$$

where m - the value assumed for gravelly, coarse and medium sands;

$$M_t = 7,8 + 7,8 + 3,9 + 0,3 + 5 = 24,8 - \text{dimensionless coefficient numerically}$$

equal to the sum of absolute values of average monthly negative temperatures during the winter in the area.

$$d_{fn} = 0,30\sqrt{24,8} = 1,50m;$$

The calculated depth of seasonal soil freezing d_f , m, is determined by the formula:

$$d_f = k_h d_{fn};$$

$k_h = 0,7$ - coefficient, taking into account the effect of the thermal regime of the structure, taken: for external foundations of heated.

$$d_f = 0,7 \cdot 1,50 = 1,05m;$$

Setting the depth of the foundation

$$h = d_f + 0,5 = 1,05 + 0,5 \approx 1,6m;$$

Collection of loads on the foundation

Table 3.2. Collection of loads per 1 m² pavement

| | Name | p^H , kN/m ² | k | p^P , kN/m ² |
|----|---|---------------------------|-----|---------------------------|
| I | <u>Temporary load:</u> Snow load. (III snow district) | 126 | | 180 |
| II | <u>Constant loads:</u> | | | |
| | - Shinglas soft shingles | 10 | 1,3 | 13 |
| | - OSB sheets 12mm | 7,9 | 1,2 | 9,5 |
| | - Continuous planking | 32 | 1,2 | 38,4 |
| | - Purlins (50×100 bar) | 4 | 1,2 | 5 |
| | - Trusses (step 1,8 m) | 15 | 1,2 | 18 |
| | | 68,9 | | 83,9 |
| | TOTAL: | 194,9 | | 263,9 |
| | To calculate: | 195 | | 264 |

Table 3.3. Collection of loads per 1 m² of floorin

| | Name | p ^h , kN/m ² | k | p ^p , kN/m ² |
|----|---|------------------------------------|-----|------------------------------------|
| I | <u>Temporary load:</u> Useful for office space | 200 | 1,2 | 240 |
| II | <u>Constant loads:</u> | | | |
| | - Linoleum 5 mm | 4 | 1,3 | 5,2 |
| | - Self-leveling floor 10 mm | 1,5 | 1,3 | 1,9 |
| | - 20mm cement-sand screed | 36 | 1,3 | 46,8 |
| | - Monolithic reinforced concrete slab 200 mm | 500 | 1,1 | 550 |
| | - Suspended ceiling | 20 | 1,2 | 24 |
| | | 561,5 | | 627,9 |
| | TOTAL: | 761,5 | | 867,9 |
| | To calculate: | 762 | | 870 |

Collection of loads per 1 m of the foundation along the axis 1:

The width of the conditional strip: 3.6m.

- Load from the pavement:

$$N_1^h = 195 \cdot 3,6 = 702N;$$

$$N_1^p = 264 \cdot 3,6 = 950N;$$

- Load from the wall:

$$N_1^h = 2400 \cdot 0,4 \cdot 9 = 8640N/m;$$

$$N_1^p = N_1^h \cdot 1,1 = 8640 \cdot 1,1 = 9504N/m;$$

- Load from 2 slabs:

$$N_2^h = 762 \cdot 3,6 \cdot 2 = 5488N/m;$$

$$N_2^p = 870 \cdot 3,6 \cdot 2 = 6264N/m;$$

- Load from the strip foundation:

We take a preliminary foundation 2-step width of 1500:

$$N_3^h = (1,5 \cdot 0,3 + 0,9 \cdot 0,3) \cdot 2400/1,5 = 1152N/m;$$

$$N_3^P = N_1^H \cdot 1,1 = 1152 \cdot 1,1 = 1267N/m;$$

- Load from the ground at the foundation's edges:

$$N_4^H = 0,6 \cdot 1,6 \cdot 1920 \cdot 1 = 2650N/m;$$

$$N_4^P = N_4^H \cdot 1,1 = 2650 \cdot 1,1 = 2915N/m;$$

Total per 1 meter of base:

$$\Sigma^H = 702 + 8640 + 5488 + 1152 + 2650 = 18,63kN/m;$$

$$\Sigma^P = 950 + 9504 + 6264 + 1267 + 2915 = 20,90kN/m;$$

Collection of loads on column foundations for columns in B/C axes:

Cargo area $7,2 \times 3 = 21,6 \text{ m}^2$.

- Load from the coating:

$$N_1^H = 195 \cdot 21,6 = 4212$$

$$N_1^P = 264 \cdot 21,6 = 5702N;$$

- Load from the column:

$$N_1^H = 0,4 \cdot 1 \cdot 8,7 \cdot 2400 = 8352N;$$

$$N_1^P = N_1^H \cdot 1,1 = 8352 \cdot 1,1 = 9187N;$$

- Load from 2 slabs:

$$N_3^H = 762 \cdot 21,6 \cdot 2 = 32918N;$$

$$N_3^P = 870 \cdot 21,6 \cdot 2 = 37584$$

- Load from the ground at the foundation's edges:

$$N_4^H = 0,6 \cdot 1,15 \cdot 1920 \cdot 1 = 1325N/m;$$

$$N_4^P = N_4^H \cdot 1,1 = 1325 \cdot 1,1 = 1457N/m;$$

- Load from the foundation:

Take a preliminary columnar 3-step foundation:

$$N_4^H = (1,8 \cdot 1,8 \cdot 0,3 + 1,2 \cdot 1,2 \cdot 0,3 + 0,6 \cdot 0,6 \cdot 0,3) \cdot 2400 = 3629N;$$

$$N_4^P = N_4^H \cdot 1,1 = 3629 \cdot 1,1 = 3992N;$$

Total for 1 m² base:

$$\Sigma^H = \frac{4212 + 8352 + 32918 + 1325 + 3629}{1,8 \cdot 1,8} = 15,57kN/m^2;$$

$$\Sigma^H = \frac{5702 + 9187 + 37584 + 1457 + 3992}{1,8 \cdot 1,8} = 17,88 \text{ kN/m}^2;$$

Determining the dimensions of the foundations

Determine the bearing capacity of the soil at the base of the building

$$R = \frac{\gamma_{c1} \cdot \gamma_{c2}}{k} [M_y \cdot k_z \cdot b \cdot \gamma_{II} + M_q \cdot d_1 \cdot \gamma'_{II} + (M_q - 1) \cdot d_b \cdot \gamma'_{II} + M_c \cdot C_{II}];$$

Here:

$\gamma_{c1}=1,4$ - coefficient of working conditions (coarse sand);

$\gamma_{c2}=1,2$ - factor of working conditions for the building with a rigid structural scheme at the ratio of the length of the structure to the height

$$L/H=50,4/11,3=4,46>4;$$

$k=1,1$ - strength characteristics of the soil

$$\varphi_{II} = 40^0 \Rightarrow M_g = 2,46;$$

$$M_q = 10,85;$$

$$M_c = 11,73;$$

$$C_{II} = 3\kappa \text{ IIa};$$

$$\gamma_{II} = 1,92 \text{ kN/m}^3;$$

$$\gamma_I = \gamma_{II} \times \gamma_{\text{mri}} = 1,92 \cdot 0,95 = 1,82 \text{ kN/m}^3;$$

$$R = \frac{1,4 \cdot 1,2}{1,1} [2,46 \cdot 1 \cdot 1,5 \cdot 1,82 + 10,85 \cdot 2,6 \cdot 1,82 + (10,85 - 1) \cdot 2 \cdot 1,82 + 11,73 \cdot 0,3] = 149 \text{ kN/m}^2;$$

For

strip foundation under the walls in the axes 1/A-D, 4/A-D, 5/A-D, 8/A-D:

Average pressure under the base of the foundation:

$$P_{cp} = \frac{N^H}{1 \times b} = \frac{18,63}{1 \times 1,5} = 12,42 \text{ kN/m}^2 < R = 149 \text{ kN/m}^2;$$

Since there is a significant understressing, we don't calculate the foundation for the pressure. Let's select the concrete class of the foundation and the reinforcement.

Selection of concrete class and reinforcement

a) Calculation by the edge of the first stage:

Console length 30 cm = 0.3 m.

Table 3.4. Calculation results

| Name of soil layer | Relative depth, m | Absolute Depth, m | Stress change coefficient by depth | Additional Pressure, kPa | Pressure from the weight of the ground, kPa | 0,2*Zg | Deformation modulus, kPa | Layer settlement, mm |
|--------------------|-------------------|-------------------|------------------------------------|--------------------------|---|--------|--------------------------|----------------------|
| Coarse sand | 0,000 | 0,000 | 1,000 | 96,600 | 42,400 | 8,480 | 40000 | 0,39 |
| | 0,267 | 0,200 | 0,973 | 94,024 | 46,294 | 9,259 | | 0,38 |
| | 0,533 | 0,400 | 0,928 | 89,645 | 50,188 | 10,038 | | 0,36 |
| | 0,800 | 0,600 | 0,800 | 77,280 | 54,082 | 10,816 | | 0,31 |
| | 1,067 | 0,800 | 0,716 | 69,166 | 57,976 | 11,595 | | 0,28 |
| | 1,333 | 1,000 | 0,568 | 54,901 | 61,870 | 12,374 | | 0,22 |
| | 1,600 | 1,200 | 0,449 | 43,373 | 65,764 | 13,153 | | 0,17 |
| | 1,867 | 1,400 | 0,388 | 37,449 | 69,658 | 13,932 | | 0,15 |
| | 2,133 | 1,600 | 0,312 | 30,107 | 73,552 | 14,710 | | 0,12 |
| | 2,400 | 1,800 | 0,257 | 24,826 | 77,446 | 15,489 | | 0,10 |
| | 2,667 | 2,000 | 0,219 | 21,155 | 81,340 | 16,268 | | 0,08 |
| Sandy loam | 2,933 | 2,200 | 0,186 | 17,935 | 85,234 | 17,047 | 13000 | 0,22 |
| | 3,200 | 2,400 | 0,160 | 15,456 | 89,128 | 17,826 | | 0,19 |
| | 3,467 | 2,600 | 0,135 | 13,073 | 93,022 | 18,604 | | 0,16 |
| | 3,733 | 2,800 | 0,121 | 11,656 | 96,916 | 19,383 | | 0,14 |
| | 4,000 | 3,000 | 0,108 | 10,433 | 100,810 | 20,162 | | 0,13 |
| | 4,267 | 3,200 | 0,091 | 8,758 | 104,704 | 20,941 | | 0,11 |
| | 4,533 | 3,400 | 0,084 | 8,082 | 108,598 | 21,720 | | 0,10 |
| | 5,867 | 4,400 | 0,048 | 4,637 | 112,492 | 22,498 | | 0,06 |
| | 7,200 | 5,400 | 0,036 | 3,478 | 116,386 | 23,277 | | 0,04 |
| | 8,533 | 6,400 | 0,024 | 2,286 | 120,280 | 24,056 | | 0,03 |
| | 9,867 | 7,400 | 0,016 | 1,546 | 124,174 | 24,835 | | 0,02 |
| | 11,200 | 8,400 | 0,015 | 1,449 | 128,068 | 25,614 | | 0,02 |
| 12,533 | 9,400 | 0,013 | 1,256 | 131,962 | 26,392 | 0,02 | | |
| | | | | | | | Amount | 3,61 |

Calculation pressure under the foundation's underside

$$P_{cp}^p = \frac{N^p}{1 \times b} = \frac{20,90}{1 \times 1,5} = 13,93 \text{ kN/m}^2 < R = 149 \text{ kN/m}^2;$$

Calculation moment on the width of the sole

$$M = \frac{P_p \times b \times C^2}{2} = \frac{13,93 \times 1 \times 0,3^2}{2} = 0,87 \text{ kNm};$$

$$R_s = 3750 \text{ N/cm}^2;$$

$$A_s^{mp} = \frac{M}{0,9 \times R_s \times h_0} = \frac{0,87 \times 10^5}{0,9 \times 3750 \times 25} = 1,03 \text{ cm}^2;$$

b) Calculation on the edge of the sub-column:

$$M = \frac{P_p \times b \times C^2}{2} = \frac{13,93 \times 1 \times 0,6^2}{2} = 3,47 \text{ kNm};$$

$$R_s = 3750 \text{ N/cm}^2;$$

$$A_s^{mp} = \frac{M}{0,9 \times R_s \times h_0} = \frac{3,47 \times 10^5}{0,9 \times 3750 \times 55} = 1,87 \text{ cm}^2;$$

Accept:

4Ø10A400

$$A_s = 4 \times 0,79 = 3,14 \text{ cm}^2 > 1,87 \text{ cm}^2 = A_s^{mp};$$

The foundation slab is reinforced with a grid of Ø 10 A400 with a mesh of 200 × 200 mm.

Calculation of foundation settlement in axes 1,4,5,9/A-D

We calculate by the method of layer-by-layer summation, the natural stresses at the level of the foundation's underside are

$$\sigma_{zp} = N_{zp}^H \cdot 1,6 = 2,650 \cdot 1,6 = 42,40 \text{ kPa};$$

Additional stresses from the load at the foot of the foundation are $P_0 = 139 - 42,40 = 96,60 \text{ kPa}$;

Calculation of foundation settlement in axes 1,4,5,9/A-D

The required footprint of the foundation is determined from the condition

$$A_{\phi}^{mp} = \frac{N}{R_0 - \gamma_{cp} \cdot H} = \frac{50,45}{149 - 1,92 \cdot 1,6} = 0,35m^2;$$

Where $N = 15,57 \cdot 1,8 \cdot 1,8 = 50,45kN$ - force acting on one column.

$\gamma_{cp} = 1,92t/m^3$ - the average volume weight of the soil and the foundation base material;

H - the depth of the foundation is preliminarily equal to 1.6m.

1.8×1.8 - the preliminary dimensions of the foundation.

We see that due to the high load-bearing capacity of the soil, we can see that for a given area of the foundation, there is a low loading of the soil, about half of its capacity. Then, the main condition for selecting the foundation is the strength of the concrete in terms of tangential stresses.

Reactive ground pressure under the sole

$$p'_{cp} = \frac{N}{a_{\phi} \cdot b_{\phi}} = \frac{50,45mc}{1,8m \cdot 1,8m} = 15,57mc/m^2 \leq R_0 = 149kN/m^2;$$

Determine the height and configuration of the foundation based on three conditions:

1. The condition of the strength of the punching:

$$\begin{aligned} h'_{\phi} &= -\frac{h_k + b_k}{4} + \frac{1}{2} \sqrt{\frac{N}{R_{bt} + p'_{cp}}} = \\ &= -\frac{0,4m + 0,4m}{4} + \frac{1}{2} \sqrt{\frac{50,4c}{0,9 \cdot 86,7 + 15,57}} = 0,168m = 16,8cm; \end{aligned}$$

Here $R_{bt} = 86,7kN/m^2$ - design tensile strength of the foundation's concrete of class C8/10.

Given the presence of concrete preparation under the foundation's underside, we take full height: $h'_{\phi} = 16,8cm + 10cm \approx 30cm$;

2. Constructive height condition:

$$h''_{\phi} = 1,5h_{\kappa} + 5 + 20 = 1,5 \cdot 40 + 5 + 20 = 85cm;$$

3. The condition of the column's rigid restraint in the foundation:

$$h_{\phi}''' = 24d_s + 25 = 30 \cdot 1,4 + 25 = 67 \text{ cm};$$

We take the foundation with a height of $h_{\phi} = 90 \text{ cm}$, three-stage (30sm+30sm +30sm).

$$h_o = 90 - 4 = 86 \text{ cm}.$$

Let's check if the height of the bottom step of the foundation is sufficient. Since its height is greater than the required minimum height from the condition of the punching, we do not perform the punching test. Shear strength condition outside the punching pyramid in the absence of transverse reinforcement:

a) Calculation by the first stage facet:

Console length 30 sm = 0,3m.

Calculation moment on the width of the sole:

$$M = \frac{P_p \times b \times C^2}{2} = \frac{15,57 \times 1,8 \times 0,3^2}{2} = 1,52 \text{ kNm};$$

$$R_s = 3750 \text{ N/cm}^2;$$

$$A_s^{mp} = \frac{M}{0,9 \times R_s \times h_0} = \frac{1,52 \times 10^5}{0,9 \times 3750 \times 25} = 1,80 \text{ cm}^2;$$

b) Calculation on the edge of the sub-column:

$$M = \frac{P_p \times b \times C^2}{2} = \frac{15,57 \times 1,8 \times 0,6^2}{2} = 6,09 \text{ m} \cdot \text{M};$$

$$R_s = 3750 \text{ N/cm}^2;$$

$$A_s^{mp} = \frac{M}{0,9 \times R_s \times h_0} = \frac{6,09 \times 10^5}{0,9 \times 3750 \times 55} = 3,28 \text{ cm}^2;$$

Take a reinforcement mesh of $\varnothing 10$ A400 with a mesh of 200×200 mm,
 $A_s = 3,9 \text{ cm}^2$.

Calculation of foundation settlement in axes 2,3,6,7/A-D

We calculate by the method of layer-by-layer summation, the natural stresses at the level of the foundation's underside are $\sigma_{zp} = N_{zp}^H \cdot 1,6 = 1,325 \cdot 1,6 = 21,2 \text{ kPa}$;

Additional stresses from the load at the foot of the foundation are $P_0 = 156 - 21,2 = 134,8 \text{ kPa}$;

Table 3.5. Calculation results

| Name of soil layer | Relative depth, m | Absolute Depth, m | Stress change coefficient by depth | Additional Pressure, kPa | Pressure from the weight of the ground, kPa | $0,2*Zg$ | Deformation modulus, kPa | Layer settlement, mm |
|--------------------|-------------------|-------------------|------------------------------------|--------------------------|---|----------|--------------------------|----------------------|
| Coarse sand | 0,000 | 0,000 | 1,000 | 134,800 | 21,200 | 4,240 | 40000 | 0,54 |
| | 0,267 | 0,200 | 0,985 | 132,733 | 25,094 | 5,019 | | 0,53 |
| | 0,533 | 0,400 | 0,945 | 127,386 | 28,988 | 5,798 | | 0,51 |
| | 0,800 | 0,600 | 0,881 | 118,759 | 32,882 | 6,576 | | 0,48 |
| | 1,067 | 0,800 | 0,797 | 107,436 | 36,776 | 7,355 | | 0,43 |
| Sandy loam | 1,333 | 1,000 | 0,717 | 96,697 | 40,670 | 8,134 | 13000 | 1,19 |
| | 1,600 | 1,200 | 0,642 | 86,542 | 44,564 | 8,913 | | 1,07 |
| | 1,867 | 1,400 | 0,581 | 78,274 | 48,458 | 9,692 | | 0,96 |
| | 2,133 | 1,600 | 0,526 | 70,860 | 52,352 | 10,470 | | 0,87 |
| | 2,400 | 1,800 | 0,477 | 64,300 | 56,246 | 11,249 | | 0,79 |
| | 2,667 | 2,000 | 0,439 | 59,177 | 60,140 | 12,028 | | 0,73 |
| | 2,933 | 2,200 | 0,405 | 54,549 | 64,034 | 12,807 | | 0,67 |
| | 3,200 | 2,400 | 0,374 | 50,415 | 67,928 | 13,586 | | 0,62 |
| | 3,467 | 2,600 | 0,349 | 47,090 | 71,822 | 14,364 | | 0,58 |
| | 3,733 | 2,800 | 0,327 | 44,035 | 75,716 | 15,143 | | 0,54 |
| | 4,000 | 3,000 | 0,306 | 41,249 | 79,610 | 15,922 | | 0,51 |
| | 4,267 | 3,200 | 0,289 | 38,912 | 83,504 | 16,701 | | 0,48 |
| | 4,533 | 3,400 | 0,273 | 36,755 | 87,398 | 17,480 | | 0,45 |
| | 4,800 | 3,600 | 0,258 | 34,778 | 91,292 | 18,258 | | 0,43 |
| | 5,067 | 3,800 | 0,245 | 33,071 | 95,186 | 19,037 | | 0,41 |
| | 5,333 | 4,000 | 0,234 | 31,498 | 99,080 | 19,816 | | 0,39 |
| | 5,600 | 4,200 | 0,223 | 30,060 | 102,974 | 20,595 | | 0,37 |
| | 5,867 | 4,400 | 0,213 | 28,712 | 106,868 | 21,374 | | 0,35 |
| | 6,133 | 4,600 | 0,204 | 27,499 | 110,762 | 22,152 | | 0,34 |
| | 6,400 | 4,800 | 0,196 | 26,421 | 114,656 | 22,931 | | 0,33 |
| 6,667 | 5,000 | 0,189 | 25,432 | 118,550 | 23,710 | 0,31 | | |
| 6,933 | 5,200 | 0,182 | 24,489 | 122,444 | 24,489 | 0,30 | | |
| 7,200 | 5,400 | 0,175 | 23,590 | 126,338 | 25,268 | 0,29 | | |
| | | | | | | | Amount: | 15,46 |

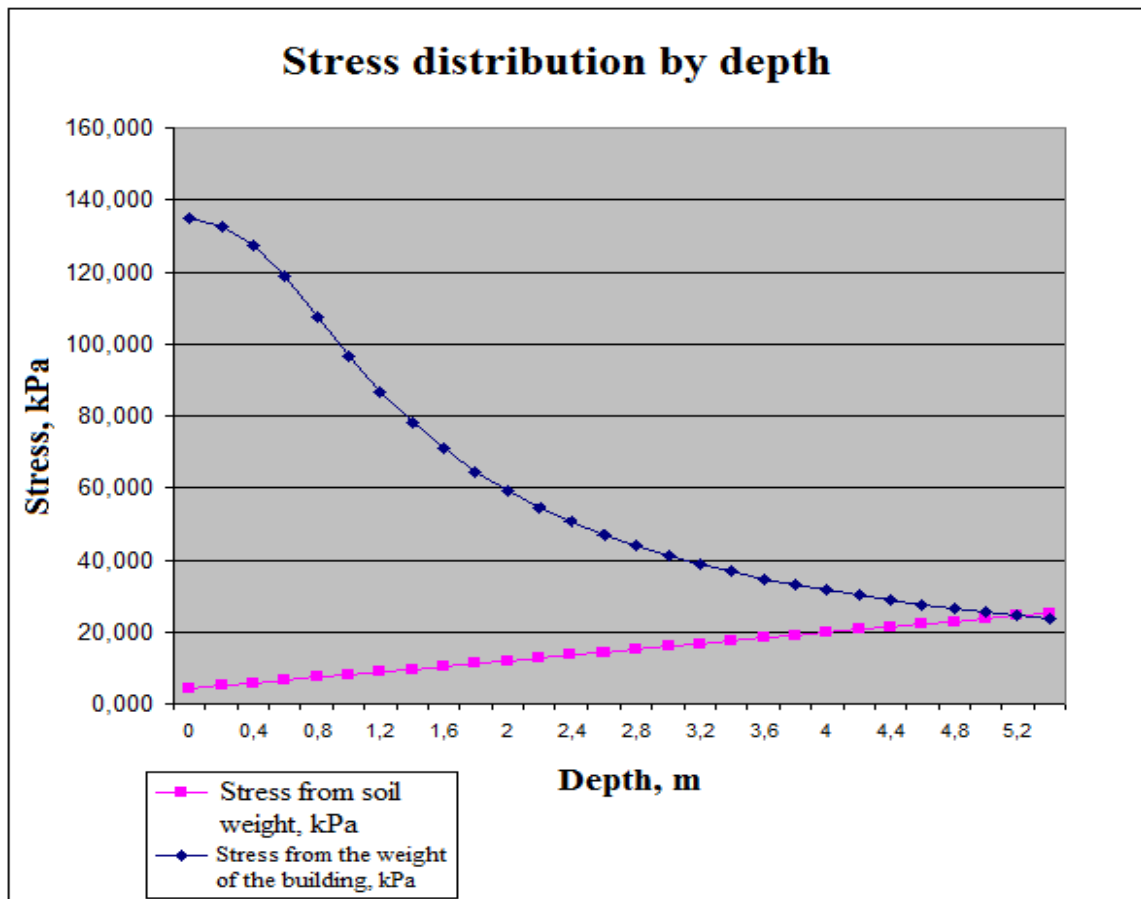

Design of the pile foundation in the axes 1,4,5,9/A-D

Let us design a pile foundation along the axes 2, 3, 6, 7/A-D. We will take the pile C60.30-6 (series 1.011.1-10). The bearing capacity of any type of pile is determined by the following formula:

$$F_d = \gamma_c \left(\gamma_{cR} R A + U \sum \gamma_{cf} f_i h_i \right);$$

Here $R=135 \text{ ts/m}^2$ is the design resistance of the soil under the bottom end of the pile (for sandy soils with $J_L = 0,5$)

$\gamma_c = 1$ - the coefficient of working conditions;

$A=0.09$ - cross-sectional area of the pile;

$U=1,2\text{m}$ - perimeter of the pile cross section;

$\gamma_{cR} = 1, \gamma_{cf} = 1$ - coefficients of soil work under the bottom end of the pile and on the side surface.

f_i, h_i - design resistance on the lateral surface and the thickness of the i-th layer of soil.

$$f_1 = 1,5h_1 = 1m;$$

$$f_2 = 1,7h_2 = 1,4m;$$

$$f_3 = 2,7h_3 = 2m;$$

$$f_4 = 3,1h_4 = 2m;$$

$$f_4 = 3,1h_4 = 0,6m;$$

$$F_d = 1 \cdot [1 \cdot 135 \cdot 0,09 + 1,2(1,5 \cdot 1 + 1,7 \cdot 1,4 + 2,7 \cdot 2 + 3,1 \cdot 0,6)] = 32,65kN;$$

Permissible load on the pile:

$$F = \frac{F_d}{\gamma_g} = \frac{32,65}{1,4} = 23,32kN;$$

Determine the number of piles per 1 p.m. of the rooftop:

$$n = \frac{N_{II}}{f} = \frac{20,90}{23,32} = 0,90 \approx 1;$$

According to the requirements, the minimum distance between piles must be at least

$$S_{\min} = 3d = 3 \times 0,3m = 0,9m, \text{ maximum pile spacing } S_{\max} = 6d = 6 \times 0,3m = 1,8m.$$

take the pitch of the piles 1 m.

The height of the rooftop 30 cm. Coupling piles with the dike take articulated, the depth of embedding piles in the dike 0.1 m. The width of the grill is taken 0.9m.

The weight of the rostrum per 1 m of the foundation:

$$G_p = 2,4 \cdot 0,3 \cdot 0,9 = 0,648m;$$

The weight of the soil on the beam:

$$G_{rp} = 1,92 \cdot 0,6 \cdot 0,9 = 1,037t;$$

Total load per pile:

$$N = 20,90 + 0,648 + 1,037 = 22,85 < F = 23,32.$$

Determination of the conditional width of the pile foundation:

$$\varphi_{II} m t = \frac{\sum \varphi_{II} h_i}{\sum h_i} = \frac{45 \cdot 0,4 + 40 \cdot 1,4 + 23 \cdot 2}{0,4 + 1,4 + 2} = 31,58 - \text{the calculated value of the angles of}$$

internal friction for different soil layers.

$$\alpha = \frac{\varphi_{II} m t}{4} = \frac{31,58}{4} = 7,90 - \text{scattering angle.}$$

$$B_{ycr} = 2tg\alpha \cdot \sum h_i = 2 \cdot 0,139 \cdot 6 = 1,665m;$$

Calculation of pile foundation settlement

We calculate the settlement by the method of layer-by-layer summation. The natural stresses at the level of the foundation's underside are:

$$\sigma_{zp} = (0,3M \cdot 0,6 \cdot 1M) \cdot 1,92mc/M = 0,384mc/\kappa\text{в.м.} = 3,84\kappa\Pi\text{a};$$

Additional stresses from the load at the level of the foundation's underside are

$$P_0 = 186,3 - 3,84 = 182,46 \text{ kPa};$$

Table 3.6. Calculation results

| Name of soil layer | Relative depth, m | Absolute Depth, m | Stress change coefficient by depth | Additional Pressure, kPa | Pressure from the weight of the ground, kPa | $0,2 \cdot Zg$ | Deformation modulus, kPa | Layer settlement, mm |
|--------------------|-------------------|-------------------|------------------------------------|--------------------------|---|----------------|--------------------------|----------------------|
| Coarse sand | 0,000 | 0,000 | 1,000 | 182,460 | 3,840 | 0,768 | 40000 | 0,73 |
| | 0,267 | 0,200 | 0,985 | 179,662 | 7,734 | 1,547 | | 0,72 |
| | 0,533 | 0,400 | 0,928 | 169,323 | 11,628 | 2,326 | | 0,68 |
| | 0,800 | 0,600 | 0,800 | 145,968 | 15,522 | 3,104 | | 0,58 |
| | 1,067 | 0,800 | 0,716 | 130,641 | 19,416 | 3,883 | | 0,52 |
| | 1,333 | 1,000 | 0,568 | 103,698 | 23,310 | 4,662 | | 0,41 |
| | 1,600 | 1,200 | 0,449 | 81,925 | 27,204 | 5,441 | | 0,33 |
| | 1,867 | 1,400 | 0,388 | 70,734 | 31,098 | 6,220 | | 0,28 |
| | 2,133 | 1,600 | 0,312 | 56,867 | 34,992 | 6,998 | | 0,23 |
| | 2,400 | 1,800 | 0,257 | 46,892 | 38,886 | 7,777 | | 0,19 |
| 2,667 | 2,000 | 0,219 | 39,959 | 42,780 | 8,556 | 0,16 | | |
| Sandy loam | 2,933 | 2,200 | 0,186 | 33,877 | 46,674 | 9,335 | 13000 | 0,42 |
| | 3,200 | 2,400 | 0,160 | 29,194 | 50,568 | 10,114 | | 0,36 |
| | 3,467 | 2,600 | 0,135 | 24,693 | 54,462 | 10,892 | | 0,30 |
| | 3,733 | 2,800 | 0,121 | 22,017 | 58,356 | 11,671 | | 0,27 |
| | 4,000 | 3,000 | 0,108 | 19,706 | 62,250 | 12,450 | | 0,24 |
| | 4,267 | 3,200 | 0,091 | 16,543 | 66,144 | 13,229 | | 0,20 |
| | 4,533 | 3,400 | 0,084 | 15,266 | 70,038 | 14,008 | | 0,19 |
| | 4,800 | 3,600 | 0,077 | 14,049 | 73,932 | 14,786 | | 0,17 |
| | | | | | | | Amount: | 6,99 |

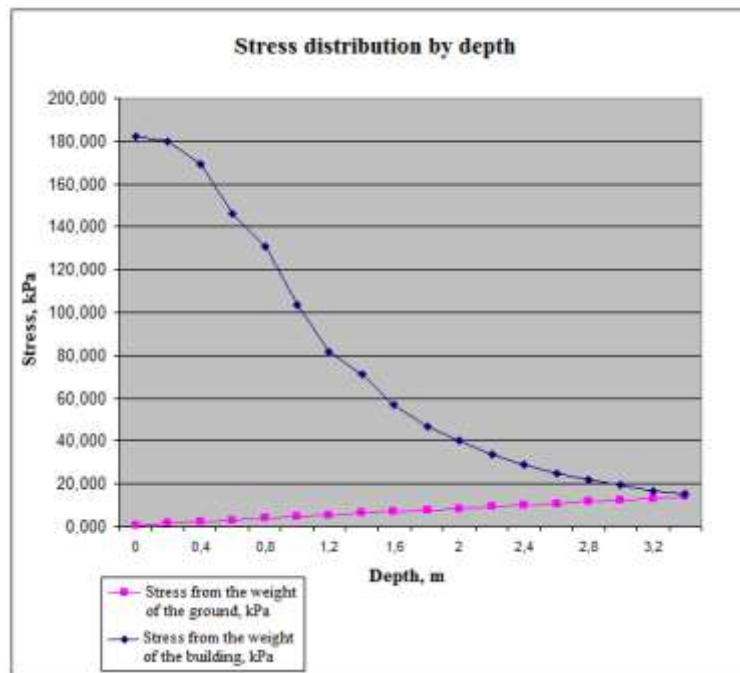

Guidelines for the waterproofing of foundations and the technology for the construction of foundations

All foundations are built with the obligatory preliminary concrete preparation of large-porous concrete of C8/10 class, 10 cm thick and equal to the width of the foundation belt or the rostrum. Along the upper edge of the foundation slab, the filler waterproofing (two layers of roofing felt) is laid with a width slightly greater than the width of the strip. The walls of the excavation are not to be reinforced, since the excavation is carried out taking into account the collapse prism. The depth of the excavation is assumed to be equal to the depth of the foundation. After the geodetic work is completed, set up the formwork on the inner side of the strip, then install the reinforcement cages, perform tying. After the completion of the formwork, proceed to concreting. Concreting is performed in 2 stages, by the number of foundation steps. The break after the first stage concreting is 3 days. To avoid cracking of the concrete during the setting of the strength, abundant watering is required, especially on hot days. When performing concrete, formwork, reinforcing works, follow the safety rules in accordance with the regulatory requirements.

3.2. Calculation of coverage

Background data for the design

| INDICATOR | MEANING |
|--------------------------|--|
| Snow load | $S_o=1,55$ kPa |
| Building type | Reinforced concrete with incomplete frame, with external load-bearing walls and internal columns |
| Cross frame pitch | 7,2 m |
| Span of cover structures | 15 m |
| Loft type | unheated |
| Type of roof | Soft shingles |
| Floor height | 3m |

Calculation of solid coverage

Calculation of solid coverage

We accept the cladding made of 32×150 mm boards of wood of the 2nd grade. Design resistance to compression, buckling and bending $R_i=130$ MPa, elastic modulus $E=105$ MPa.

Preliminary scheme of the cladding:

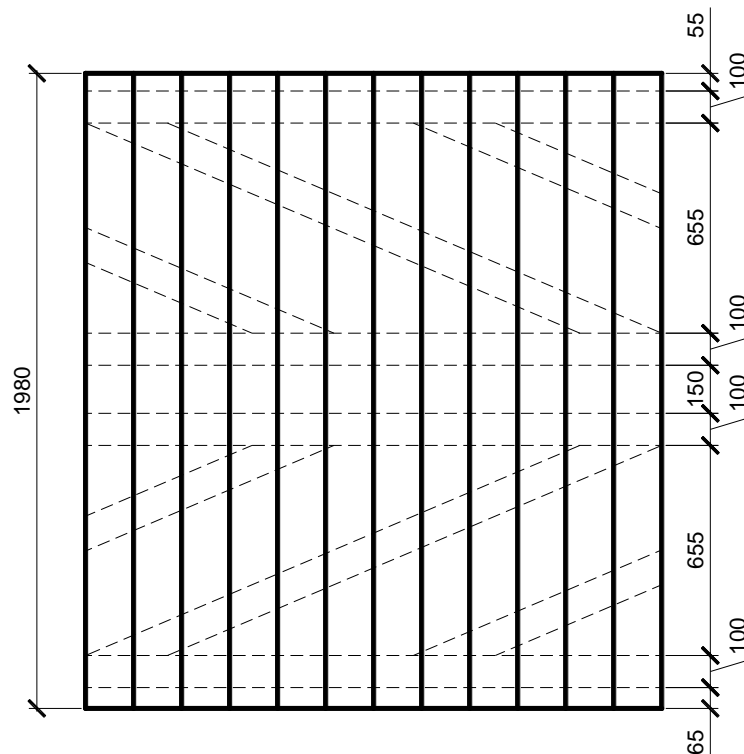

Collecting loads

Consider a 3.6 m wide strip as a design strip.

| <i>Type of load</i> | $q_n, \text{ kN/m}$ | γ_n | $q_p, \text{ kN/m}$ |
|--|---------------------|------------|---------------------|
| <i>Permanent</i> | | | |
| Soft shingles: $12 \text{ kg/m}^2 \times 1,8 \text{ m}$ | 21,60 | 1,3 | 28,08 |
| Transverse and diagonal ribs: $(4 \cdot 1,8 + 4 \cdot 1,67) \cdot 0,05 \cdot 0,100 \cdot 700/2$ | 18,45 | 1,1 | 20,30 |
| Own weight of the decking: $0,032 \cdot 1,8 \cdot 700$ | 40,32 | 1,1 | 44,35 |
| TOTAL: | 80,37 | | 92,73 |
| <i>Temporary</i> | | | |
| Snowy: $180 \cdot 1,8 \cdot 0,921$ | 208,88 | 1,429 | 298,40 |
| TOTAL: | 289,25 | | 391,13 |

Calculation of the combination of loads №1:

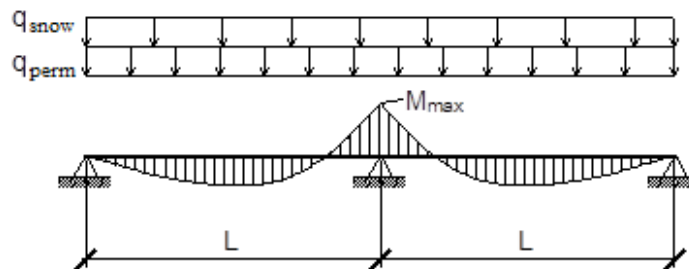

Calculation of the combination of loads number 2:

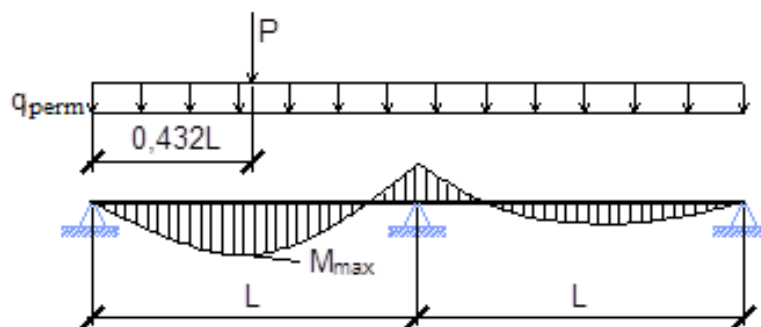

Calculation of the sheathing section

At a cross frame spacing of 1.8 m, we use single-span purlins 1.8 m long with a spacing of 1 m. Calculation is also carried out for two combinations of loads:

1. Constant and snow loads (strength and deflection);
2. Constant and mounting (strength);

Collection of loads per 1 m of purlin:

| <i>Type of load</i> | <i>q_n, kN/m</i> | <i>γ_n</i> | <i>q_p, kN/m</i> |
|--|----------------------------|----------------------|----------------------------|
| <i>Permanent</i> | | | |
| Soft shingles: 12 N/m ² ×1 m | 12 | 1,3 | 15,6 |
| Transverse and diagonal ribs: (2·1,8+1,68)·0,05·0,100·700/1,8 | 10,27 | 1,1 | 11,30 |
| Own weight of the decking: 0,032·1·700 | 22,4 | 1,1 | 24,64 |
| Own weight of the run: 0,080·0,080·700 | 15,75 | 1,1 | 17,32 |
| TOTAL: | 60,42 | | 68,86 |
| <i>Temporary</i> | | | |
| Snowy: 180·1·0,921 | 116,07 | 1,429 | 165,78 |
| TOTAL: | 176,49 | | 234,64 |

Calculation of inclined rafters

The structural solution of the rafter structure is as follows: along the inner walls there are rafters on which two push-pull props are rested, serving to reduce the span of the rafters' legs. The push-pull props are hammered into the rafters at right angles to avoid bending. Above the jamming point of the push-pull props, a brace is installed to absorb the spread of the rafters to the outside wall.

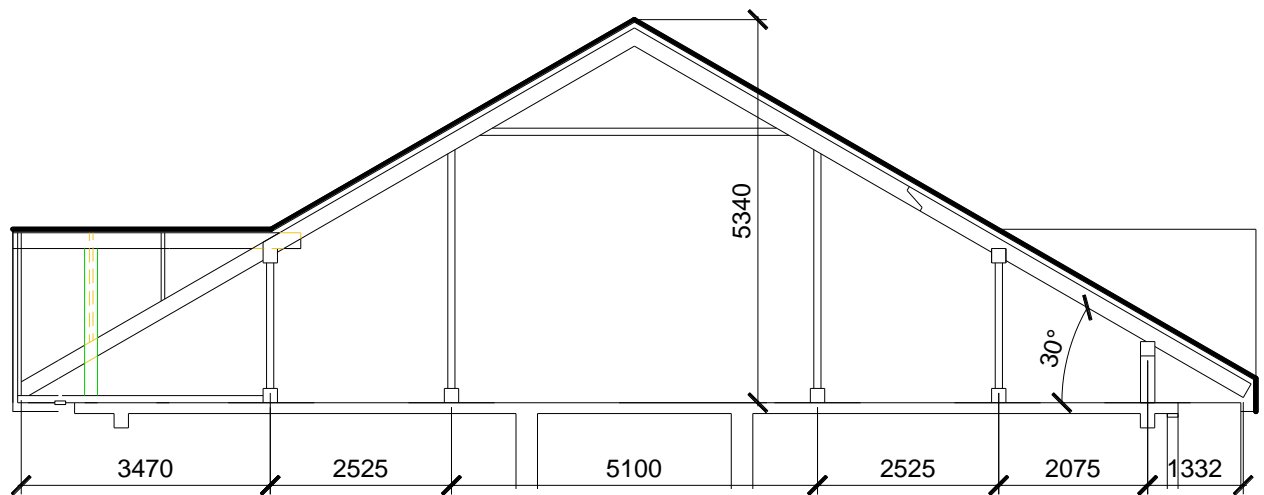

The rafters are placed on the monolithic slab. The pitch of the rafters is 1.8 m.

Collection of loads per 1 m. rafters

| <i>Type of load</i> | $q_n, kN/m$ | γ_n | $q_p, kN/m$ |
|--|-------------|------------|-------------|
| <i>Permanent</i> | | | |
| Soft shingles: $12 \text{ kg/m}^2 \cdot 1,8$ | 21,60 | 1,3 | 28,08 |
| Transverse and diagonal ribs: $4 \cdot (2 \cdot 1,8 + 1 \cdot 1,68) \cdot 0,05 \cdot 0,100 \cdot 700$ | 73,92 | 1,1 | 81,31 |
| Own weight of the decking: $0,032 \cdot 1,8 \cdot 700$ | 40,32 | 1,1 | 44,35 |
| Own weight of the run: $0,120 \cdot 0,140 \cdot 1,8 \cdot 700$ | 21,17 | 1,1 | 23,28 |
| TOTAL: | 157,01 | | 177,02 |
| <i>Temporary</i> | | | |
| Snowy: $180 \cdot 1,8 \cdot 0,921 \cdot 0,7$ | 208,88 | 1,429 | 298,40 |
| TOTAL: | 365,89 | | 475,42 |

Calculation of the rafter

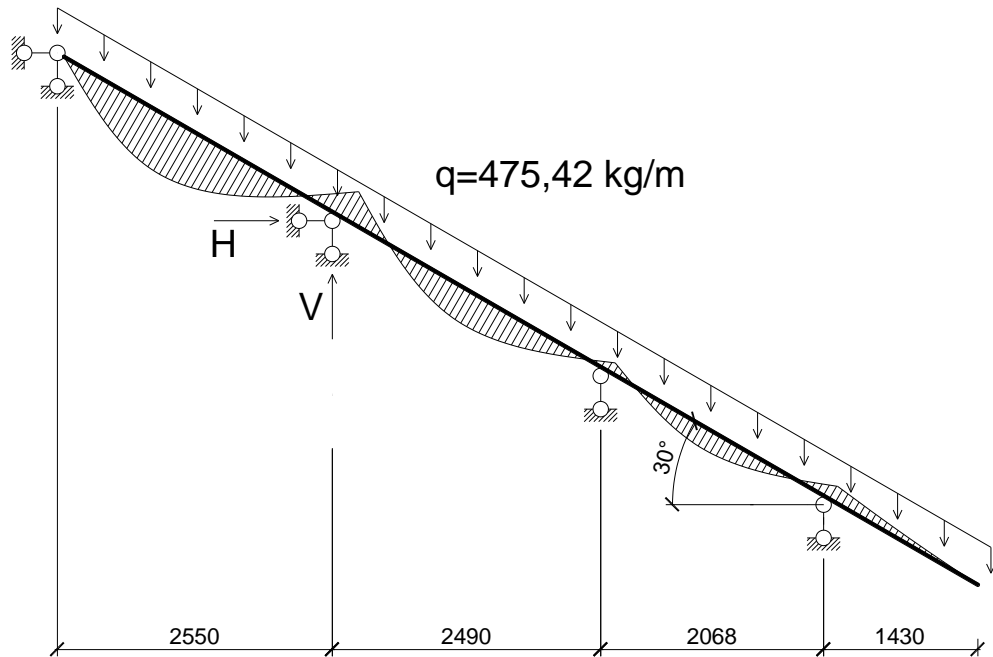

We consider the rafter as an unsplit beam on four supports with a cantilever. The dangerous section is the section at the lowest support.

Farm calculation:

A triangular lattice-less truss is constructed of two inclined board elements with cantilevers and a tie. The truss is considered as a simple rod system loaded by a uniformly distributed load.

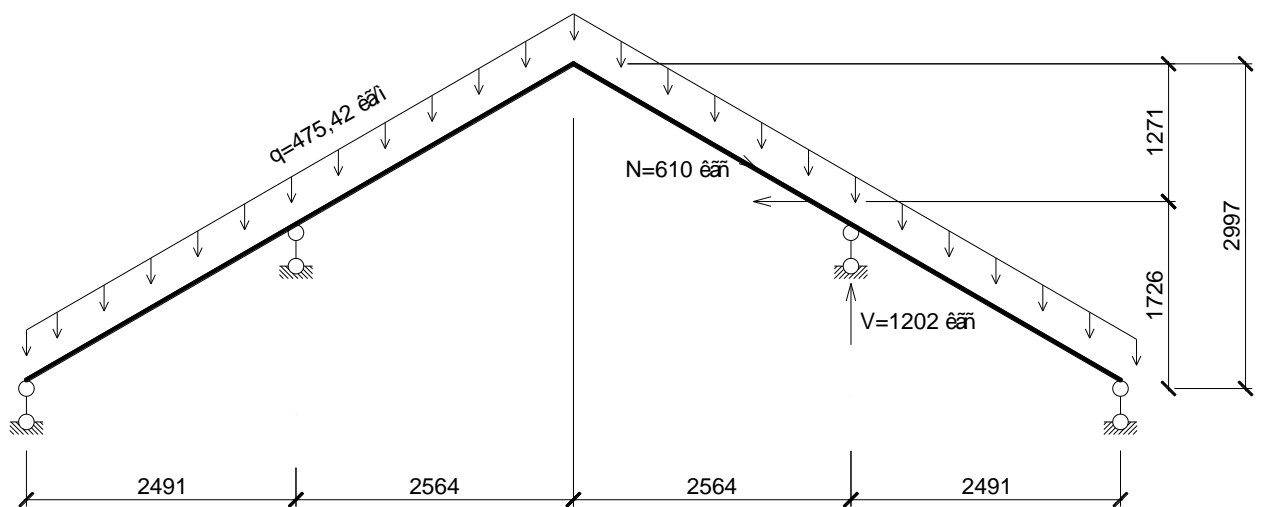

Compressive force in the top chord of the truss:

Stability of the flat form of deformation:

$$\frac{N}{\varphi_y \cdot R_c \cdot A} + \left(\frac{M}{\varphi_M \cdot R_u \cdot W} \right)^n = \frac{610}{0,274 \cdot 130 \cdot 20 \cdot 10} +$$

$$+ \left(\frac{427 \cdot 100}{9,3 \cdot 130 \cdot 483} \right)^2 = 0,09 \leq 1$$

Where: $n=2$, since the element is without anchoring the stretched edge from the plane of deformation;

$$\lambda = \frac{l_p}{i} = \frac{5,128}{0,049} = 104,65 \text{ - flexibility;}$$

$$i = 0,29 \cdot h = 0,29 \cdot 0,17m = 0,049m; \text{ - radius of inertia;}$$

$$\varphi = \frac{A}{\lambda^2} = \frac{3000}{104,65^2} = 0,274 \text{ - coefficient of longitudinal bending;}$$

$$\varphi_M = 140 \cdot \frac{b^2}{l_p \cdot h} \cdot k = 140 \cdot \frac{(0,10)^2}{1 \cdot 0,200} \cdot 1,13 = 9,3;$$

where: $L_p=1$ m is the calculated length equal to the distance between the purlins.

The force in the tightening is determined by the formula:

$$H = N \cos \alpha = 610 \text{ кгс} \cdot 0,866 = 529N;$$

In addition, the horizontal component of the tensile force in the cantilever is transferred to the bolt.

The total tensile force in the support section of the cantilever:

$$N_p = Z + qc \sin \alpha = 586 + 475,42 \cdot 1,340 \cdot 0,5 = 904,53N;$$

The horizontal component of this force:

$$N_p \cos \alpha = 904,53 \text{ кгс} \cdot 0,866 = 783,3N;$$

The total force stretching the tightening:

$$H_n = 529 + 783,32 = 1312,32kN;$$

Tightening take two boards with a section of 5×15 cm, connected to the top chord bolt ($d = 16$ mm) and four nails 8×300 mm, working as a two-cut dowels.

The carrying capacity of the bolt:

$$T_{\sigma} = 2\sqrt{k_{\alpha}} T_c = 2\sqrt{0,95} \cdot 511 = 996kN;$$

where

T_c - carrying capacity of the dowel at one shear.

Determine the shear carrying capacity of one dowel:

$$T^c = 50cd = 50 \cdot 10 \cdot 0,8 = 400\text{kN};$$

$$T^a = 80ad = 80 \cdot 5 \cdot 0,8 = 320\text{kN};$$

$$T^u = (250d^2 + a^2) = (250 \cdot 0,8^2 + 5^2) = 185\text{кгс} < 400d^2 = 400 \cdot 0,8^2 = 256\text{kN}$$

Полная расчетная несущая способность соединения:

$$0,9 (T_6 + 4 T_{гв}) = 0,9 (996 \text{ кгс} + 4 \cdot 185 \text{ кгс}) = 1562,4 > 1312,32 \text{ kN},$$

where: 0.9 - the coefficient, taking into account the reduction in the load-bearing capacity of the connection, made on the dowels of different types.

Calculated net tightening area:

$$F_{HT} = 5\text{cm} \cdot (15\text{cm} - 1,6\text{cm} - 2 \cdot 0,8\text{cm}) = 59 \text{ cm}^2$$

Tensile stress:

$$\sigma = \frac{1312,32}{59} = 22,24 \leq R_p = 70$$

Calculation of the substructure

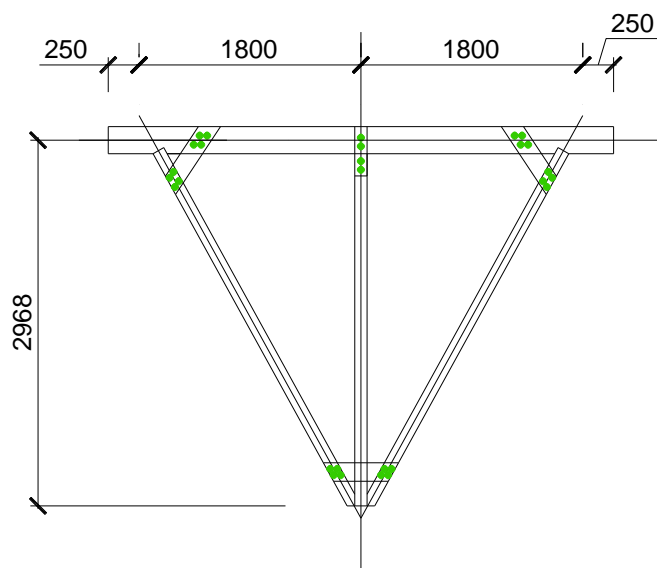

Scheme for determining the length of the frame arm outreach.

The purlins are placed on the supporting cantilever frames. The full length of the frame cantilever $a_1 = 205$ cm. The calculated outreach length can be taken equal to the full length reduced by 0.011 i.e.: $a = a_1 - 0,011 \cdot l = 205 - 0,011 \cdot 720 = 198$ cm.

Pressure from the rafters to the purlin, taking into account its own weight of the substructure (taking it roughly equal to 2.5% of the load):

$$P = 1,025 [V + q(c + l_2)] = 1,025 [1202 \text{ kN} + 426 \text{ kN/m}(2,564\text{m}+1,340\text{m})] = 3373\text{kN}.$$

From the diagram (see below) we see that the purlin only experiences a buckling load, which does not need to be checked. We accept a 100×180-section purlin without calculation.

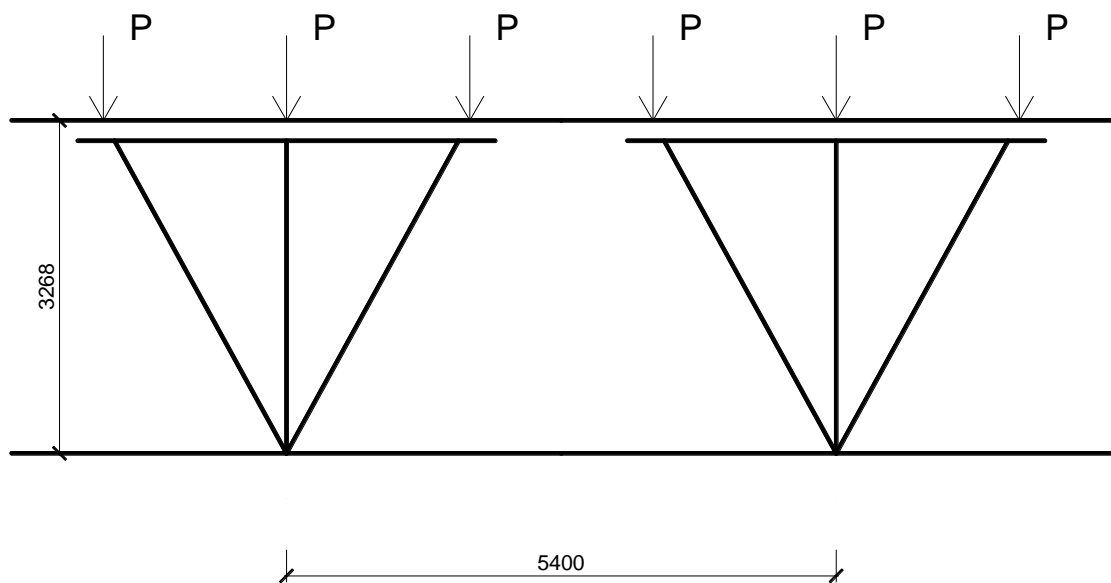

Calculation scheme of the truss structures

The bolt holes are pre-drilled only in the purlin.

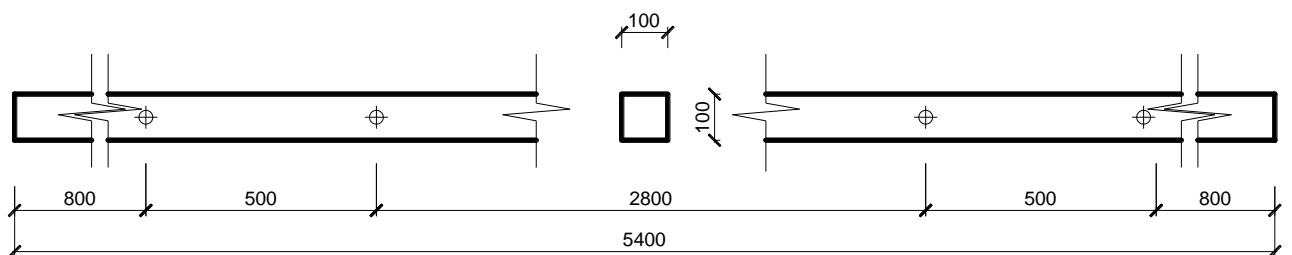
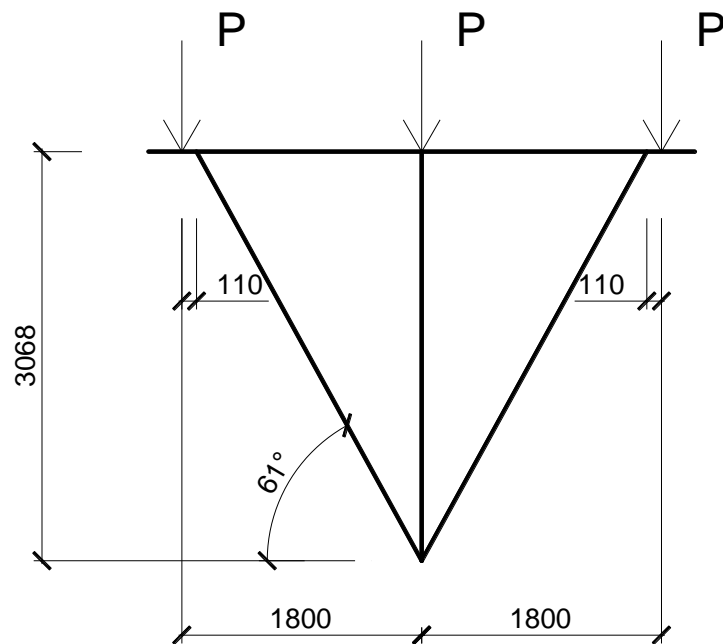

Image of the run (top view).

In the sub-girder frame holes are drilled through the purlin only after the final assembly, alignment and fastening of the purlin with the sub-girder with installation nails.

Calculation of the support frame

The support frame consists of a sub-frame, a rack and two push-pull props, fastened into a single mounting element overlays on nails.



Frame calculation diagram

The subgirder is supported by push-pull props and struts, so it can be considered as a two-span girder with brackets. The bending moment at point C of the intersection of the beam and strut axes is:

$$M_c = P \cdot 0,110 = 3373 \cdot 0,110 = 371 \text{ N} \cdot \text{m}$$

The reference pressure at point C is equal:

$$C = P + \frac{M_c}{a_2} = 3373 + \frac{371}{1,800 - 0,110} = 3593 \text{ N};$$

Tangent of the angle of inclination of the strut axis to the horizon:

$$\text{tg} \beta = \frac{3068}{1800 - 110} = 1,815;$$

It corresponds to this: $\beta = 61,14^\circ$; $\cos \beta = 0,483$; $\sin \beta = 0,876$.

Compressive force in the strut:

$$N = \frac{C}{\sin \beta} = \frac{3593 \text{ krc}}{0,876} = 4102 \text{ N};$$

The free length of the strut:

$$l_0 = \frac{3068}{0,876} = 3502 \text{ mm};$$

The cross-section of the strut we take 10×15 cm.

Then:

$$\lambda = \frac{l_0}{0,29h} = \frac{350,2\text{cm}}{0,29 \cdot 15\text{cm}} = 80;$$

$$\varphi = \frac{3000}{\lambda^2} = \frac{3000}{80^2} = 0,469;$$

$$\sigma = \frac{N}{\varphi F} = \frac{4102}{0,469 \cdot 10 \cdot 15} = 58,3 \leq R_c = 150;$$

The depth of cutting into the sub-framework of the strut is taken equal:

$$h_{\text{BP}} = 3 \text{ cm.}$$

Buckling stress in the joint:

$$\sigma_{\text{CM}} = \frac{N \cos \beta}{bh_{\text{ep}}} = \frac{4102 \cdot 0,483}{10 \cdot 5} = 39,6 \leq R_{\text{CM}\beta} = 40,7$$

$$\text{Where: } R_{\text{CM}\beta} = \frac{R_{\text{CM}}}{1 + \left(\frac{R_{\text{CM}}}{R_{\text{CM}90}} - 1\right) \sin^3 \beta} = \frac{150 \frac{\text{Ksc}}{\text{cm}^2}}{1 + \left(\frac{150 \frac{\text{Ksc}}{\text{cm}^2}}{30 \frac{\text{Ksc}}{\text{cm}^2}} - 1\right) 0,876^3} = 40,7 \text{ MPa}$$

design resistance to buckling in the joint at an angle β to the direction of the fibers.

Underbalance take from a bar section of 10×22 cm.

The area and the moment of resistance of the section weakened by the cutting are equal:

$$F = (h - h_{\text{BP}})b = (22\text{cm} - 5\text{cm}) \cdot 10\text{cm} = 170\text{cm}^2$$

$$W = \frac{b(h - h_{\text{BP}})^2}{6} = \frac{10\text{cm}(22\text{cm} - 5\text{cm})^2}{6} = 482\text{cm}^3;$$

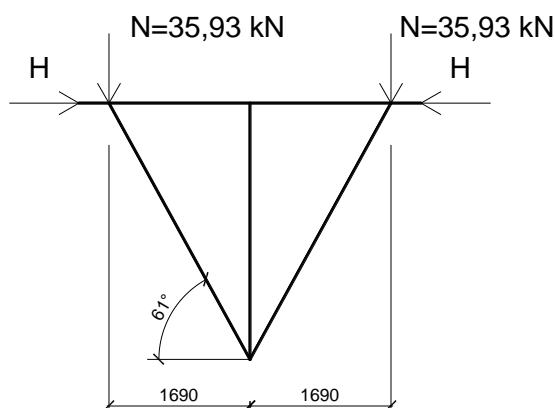

The subgirder in the calculated section works on the joint action of tension and bending.

The tensile force in the sub-beam:

$$H = \frac{C}{tg\beta} = \frac{3593}{1,815} = 1980\text{N};$$

This force with respect to the axis of the weakened section is applied with eccentricity:

$$e = \frac{h - h_{ep}}{2} + \frac{h_{ep}}{2} = \frac{h}{2} = \frac{20\text{cm}}{2} = 10\text{cm};$$

Inverse bending moment from the eccentric application of the tensile force in the substructure:

$$M_n = H_e = 1980 \text{ kN} \cdot 10 \text{ cm} = 19800 \text{ N} \cdot \text{cm}.$$

Calculated bending moment:

$$M = M_c - M_n = 371 \cdot 100 \text{ kgs} \cdot \text{cm} - 19800 \text{ kgs} \cdot \text{cm} = 17300 \text{ kgs} \cdot \text{cm}.$$

Tension of the tensile-bending element:

$$\sigma = \frac{H}{F} + \frac{M}{W} \cdot \frac{R_p}{R_u} = \frac{1980 \text{ кгс}}{170 \text{ см}^2} + \frac{17300 \text{ кгс} \cdot \text{см}}{482 \text{ см}^3} \cdot \frac{70 \frac{\text{кгс}}{\text{см}^2}}{150 \frac{\text{кгс}}{\text{см}^2}} = 28,4 \frac{\text{кгс}}{\text{см}^2} \leq R_p = 70 \frac{\text{кгс}}{\text{см}^2};$$

The cross-section of the rack is 10×15 cm.

The rack works in compression:

$$\lambda = \frac{l_0}{0,29h} = \frac{306,8 \text{ см}}{0,29 \cdot 15 \text{ см}} = 71;$$

$$\varphi = \frac{3000}{\lambda^2} = \frac{3000}{71^2} = 0,595;$$

$$\sigma = \frac{C}{\varphi \cdot F} = \frac{3593 \text{ кгс}}{0,595 \cdot 10 \text{ см} \cdot 15 \text{ см}} = 40,3 \frac{\text{кгс}}{\text{см}^2} \leq R_c = 130 \frac{\text{кгс}}{\text{см}^2};$$

Calculation of the ridge knot

Wooden elements are connected by means of wooden plates on metal bolts according to the number of elements adopted in the dowel joint and the direction of forces.

We set the diameter of the bolt $d = 2.0 \text{ cm}$ (M20 bolt).

Find the geometric dimensions of the lining:

The thickness of the linings is taken not less than half of the thickness of the elements to be fused. Then the thickness of one pad:

$$a_{\text{cov}} = \frac{1}{2} \cdot b = \frac{1}{2} \cdot 10,0 \text{ cm} = 5 \text{ cm}.$$

The total thickness at the junction: $2a_{\text{cov}} + b = 2 \cdot 5 + 10 = 20 \text{ cm}$. ($=10d = 10 \cdot 2 = 20 \text{ cm}$)

The distance between the axes of the cylindrical dowels along the wood fibers S1, across the wood fibers S2 and from the edge of the element S3 will be determined as:

$$S_1 \geq 7d = 7 \cdot 2 = 14 \text{ cm}$$

$$S_2 \geq 3,5d = 3,5 \cdot 2 = 7 \text{ cm}$$

$$S_3 \geq 3d = 3 \cdot 2 = 6 \text{ cm}$$

Determine the force per bolt row. Find the forces N_1 and N_2 by equation of moments with respect to the supports:

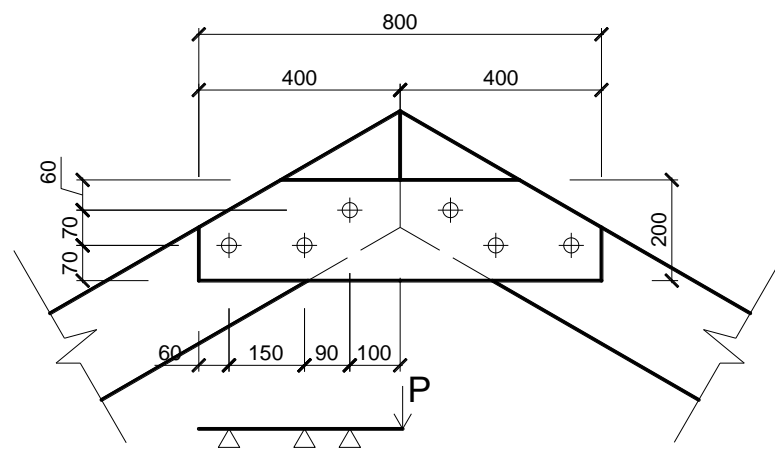

Calculation scheme of the ridge knot.

Transverse force in the ridge:

$$P = q^p l = 475,42 \text{ кгс/м} \cdot 2,55 \text{ м} = 1212 \text{ кгс};$$

a system of equations describing the equilibrium of a simple beam:

$$N_1 + N_2 + N_3 - P = 0$$

$$P \cdot 34 - N_2 \cdot 15 - N_3 \cdot 24 = 0$$

$$P \cdot 19 + N_1 \cdot 15 - N_3 \cdot 9 = 0$$

Here: N_1, N_2, N_3 - force in the first, second and third bolts respectively, starting from the left. P - the transverse force in the ridge.

Solving the system of equations, we obtain:

$$N_1 = -505 \text{ кгс}, N_2 = 0, N_3 = 1717 \text{ кгс};$$

In the dowel joint there is a buckling of the socket wood in the extreme elements (T_{ee}), in the middle elements (T_{me}) and bending of the dowel (T_{bd}).

$a = 5$ cm. - thickness of the outermost element (overlay).

$c = 10$ cm. - thickness of the middle element (rafter).

$d = 2$ cm - diameter of the bolt.

Determine the shear load capacity of one dowel:

$$T^c = 50cd = 50 \cdot 10 \cdot 2 = 1000 \text{ кгс};$$

$$T^a = 80ad = 80 \cdot 5 \cdot 2 = 800 \text{ кгс};$$

$$T^u = (180d^2 + 2a^2) = (180 \cdot 2^2 + 2 \cdot 5^2) = 770 \text{ кгс} < 250d^2 = 250 \cdot 2^2 = 1000 \text{ кгс};$$

Calculation of the required number of bolts:

$$\text{In the row where the force acts } N_1: n_1 \geq \frac{N_1}{T_{u \min} \frac{505 \text{ кгс}}{770 \text{ кгс} \cdot 3}} = 0,22_1$$

$$\text{In the row where the force } N_3: n_3 \geq \frac{N_3}{T_{u \min} \frac{1717 \text{ кгс}}{770 \text{ кгс} \cdot 3}} = 0,74_3$$

$n_j = 3$ - the number of design joints of one dowel (the bolt has 3 cuts).

3.3. Selection of reinforcement

One of the main points in the design of reinforced concrete structures is the correct selection of reinforcement, its diameter, grade, calculation of the necessary anchorage, providing a protective layer. Reinforcement takes on itself the tensile forces, does not allow the fresh concrete to crack, bulge lose its shape and performs some other useful functions. The disadvantages of ballast reinforcement include its heavy weight and low corrosion resistance. With prolonged use of the building is the inevitable penetration of water into the cracks in the walls, foundations and corrosion of the reinforcement, which greatly reduces its strength.

In my research work I decided to analyze how these disadvantages can be avoided or at least downplayed. In the last few years in the market of large Russian cities a new type of reinforcement appeared - from polymer composite materials, so called fiberglass and basalt-plastic reinforcement. All other things being equal, it is notable for low specific weight (9 times lighter than steel) that makes the work of construction workers much easier and the higher breaking strength - 3 times higher than the strength of conventional reinforcement. Thus, the 8 diameter of fiberglass replaces the 10 diameter of steel. In addition, fiberglass does not rust, it can be used in corrosive environments. Let's take a closer look at the characteristics:

| Features | Metal reinforcement of A400C class | Non-metallic composite reinforcement (ASP - fiberglass, ABP - basalt-plastic) |
|--|---|---|
| Material | Steel 35GS, 25G2S, etc. | ASP - glass fibers with a diameter of 13-16 microns bound polymer; ABP - basalt fibers with diameter of 10-16 microns bound with polymer |
| Tensile strength, MPa | 360 | 1200-ASP 1300-ABP |
| Modulus of elasticity, MPa | 200000 | 55000- ASP 71000- ABP |
| Elongation, % Relative elongation | 25 | 2,2- ASP and ABP |
| The nature of the behavior under load (stress-strain relationship) | A curve line with yield point under load | Straight line with elastic linearity under load until failure |
| Linear expansion coefficient $\alpha \times 10^{-5}/^{\circ}\text{C}$ | 13-15 | 9-12 |
| Density, t/m ³ | 7 | 1,9 - ASP and ABP |
| Corrosion resistance to aggressive media | Corrodes with evolution of rust products | Stainless material of the first group of chemical resistance, including to the alkaline environment of concrete |

| | | |
|--|---|--|
| Thermal conductivity | Heat conductive | Nonconductive |
| Electrical conductivity | Electrically conductive | Not electrically conductive - dielectric |
| Profiles produced | 6-80 | 3,5-12 in perspective up to 20 |
| Length | Rods 6-12 m long | Any length as required by the customer |
| Eco-friendliness | Environmentally friendly | Sanitary and epidemiological conclusion, does not emit any harmful and toxic substances |
| Durability | According to building standards | Forecasted durability not less than 80 years |
| Replacement of reinforcement by physical and mechanical properties | 6A400C 8A400C 12A400C 14A400C 16A400C | ASP-4, ABP-4 ASP-6, ABP -6 ASP-8, ABP -8 ASP-10, ABP -10 ASP-12, ABP -12 |
| Parameters of equal strength reinforcement cage at a load of 25 t/m ² | When using 8A400c reinforcement mesh size 14×14 cm. Weight 5,5 kg/m ² | When using a reinforcement 8ASP mesh size 23×23 cm. Weight 0.61 kg/m ² . Weight reduction of 9 times |
| Economy | At present, there has been an average increase of 67% in the cost of metal over the past 6 months | Financial savings from replacement of metal reinforcement with equal strength composite reinforcement is 10-30%. The dynamics of price growth is 2-4% per year |
| Fields of application | According to construction standards | Application as recommended. Particularly effective for road construction for products operating on an elastic base (foundations and slopes of roads, asphalt concrete pavement, retaining walls, slabs, etc.). Promising for the creation of earthquake-resistant belts of buildings and structures both existing and newly erected. |

4. Construction technology

4.1. Work technology

The work shall be carried out with the use of mechanization, advanced equipment and technology of construction works.

The PWP contains instructions:

- Regarding the scope of its application;
- Characteristics of the processes;
- Methods for carrying out the work;
- Requirements and quality control;
- Requirements for the materials used;
- Basic and specific rules of labor protection.

General construction works are performed by specialized teams of workers - specialists, trained, certified and admitted to perform these types of works under the direct supervision of engineering and technical personnel certified according to the established procedure and appointed by orders, responsible work managers.

The scope of work considered by the flowchart, includes:

- slinging and filing elements of the slab formwork roofing);
- receiving, unstringing and installation of the formwork;
- installation of the formwork in the designed position;
- installing the slab end formwork and temporary grading;
- cleaning, lubrication, storage and transportation of the formwork elements.

Installation of slab formwork with the boom crane is performed by a single unit of four men:

C1 - slinger of the 3rd category - 1 person;

P1 - a carpenter of the 4th category - one person (a linkman);

P2 - a carpenter of the 3rd category - one person; P2 - a carpenter of the 3rd category - one person;

P3 - 2nd category carpenter - one person.

Due to the fact that the carpenters have to perform need to perform slinging work, all carpenters must be trained in the slinger program and have a a slinger's certificate.

If it is necessary to perform work in two (three) shifts. The number of links shall be increased two (three) times.

In this project, it is intended to carry out the formwork structures inventory German formwork. For our case (slab thickness 100 mm, span of 6 m, pitch 7.2 m) we select the formwork panels, beams and props.

Let's choose: Thickness of the slab 14 cm → spacing of cross beams 0.5 m → permissible distance between longitudinal beams 3.93 m → spacing between longitudinal beams 3.5 m → permissible distance between supports 1.44 m

Let's choose the PEP20 girder No. 260 H=3 m, the longitudinal girder VT 20K L=3.9 m, the cross girder GT24 L=3.9 m (color green).

Concreting of walls and ceilings is performed by means of concrete pump Samsung PX321S with capacity of 100 cub.m/hour, the arm outreach up to 32 m. Formwork, fittings and other cargo are loaded/unloaded by the jib crane KS-4572 with a maximum boom lift of up to 22 m and a load moment of 20 tons per hour. When concreting, the mixture shall be compacted using IV-47 vibrator (deep vibrator with a flexible shaft). Vibrating shall be carried out in accordance with the enclosed instructions. The means of support can be: planking with guardrails on brackets fixed to the formwork or on buttresses of stiffening formwork panels (see, for example, solutions for self-supporting formwork system). Climbing platforms or platforms (type LPU 4). Concrete work must not be performed from climbing ladders.

4.2. Methods of work

The organization of the construction site must be developed and shown on the construction plan.

Before the installation of the formwork, the following work must be completed:

- the foundation for the installation of the formwork has been prepared;
- the structure of the columns and walls had been completed and acceptance certificates had been issued on the basis of the execution geodetic survey;
- elements of floor slab formwork, slab end formwork and guardrails were delivered and stacked in the crane's installation area;
- availability and marking of slab formwork, slab end formwork, guardrails were checked;
- prepared and tested mechanisms, equipment, accessories, tools;
- the lighting of working places and the construction site was arranged;
- all measures to fence openings, stairwells, the perimeter of the reinforced concrete slab in accordance with the "technological chart on the organization of collective protective equipment" were performed.

To perform work on the installation of slab (coating) formwork, the building shall be divided into segments.

Assembling the slab (coating) formwork is carried out of separate elements. Waterproof plywood 21 mm thick serves as a forming surface (deck) of the formwork. If necessary, from this or ordinary plywood is sawn out strips of necessary width and inserts of necessary configuration. The sawing places become susceptible to moisture and are subjected to moisture-resistant treatment. Such processing is carried out in the following order:

- the strips of plywood prepared of a given width are laid on liners on the rib, close to each other, and thus the resulting package has a horizontal plane to be processed;
- the entire plane is poured with melted paraffin, then the paraffin is kept in the melted state by the blowtorch to achieve uniform impregnation of the plywood face.

Standard sheets and prepared plywood strips are laid on cross beams. Cross beams are laid in accordance with the arrangement scheme, but with a spacing of not more than 750 mm along the VT20, GT24 longitudinal beams, which are also laid in accordance with the arrangement scheme. When laying the plywood sheets and strips, the outermost ones along the perimeter of the flooring (covering) are nailed to the transverse beams to prevent the plywood sheet from toppling over when people are on its cantilevered part. Supporting plywood, adjacent to the rectangular column (pylon) to produce a bar 50x50, attached to the vertical temporary support (column). The arrangement of the posts is made by technologists based on the conditions of the object. For frequently recurring conditions (the thickness of slab 200-220mm) arrangement may perform an experienced site manager or foreman.

After the installation and levelling of the floor slab (coating) formwork deck according to the working drawings, arrange a skirting of height equal to the thickness of the floor slab (coating), which is fixed to the formwork deck with screws. Such a skirting is designed and manufactured individually for complex slab configuration.

With simple rectangular solutions the boarding board is installed, resting on the corners.

The posts of temporary fencing of the floor slab (covering) are installed in the holes of the curb structure. In the absence of an individual project for the formwork face of the slab, it is performed as follows. The line of the face of the slab is made. Along it with a step of 0.5 m and an indentation of 21 mm are mounted stop angles. Plywood 21mm is attached to the angle. The fence post and boards are inserted into the socket of the angle. The joints of the floor (covering) plywood sheets are sealed with special self-adhesive single-use tapes or covered with a plastic profile. Before the beginning of the reinforcement work, all the props shall be installed. This is done in order to eliminate all reinforcement cutting operations on the formwork. The reinforcement must be prepared in advance.

The forming surface of the formwork is coated with a special lubricant.

The completed formwork is presented to the foreman (foreman) for acceptance. The finished and accepted by the foreman or foreman formwork is used to reinforce the floor slab (pavement).

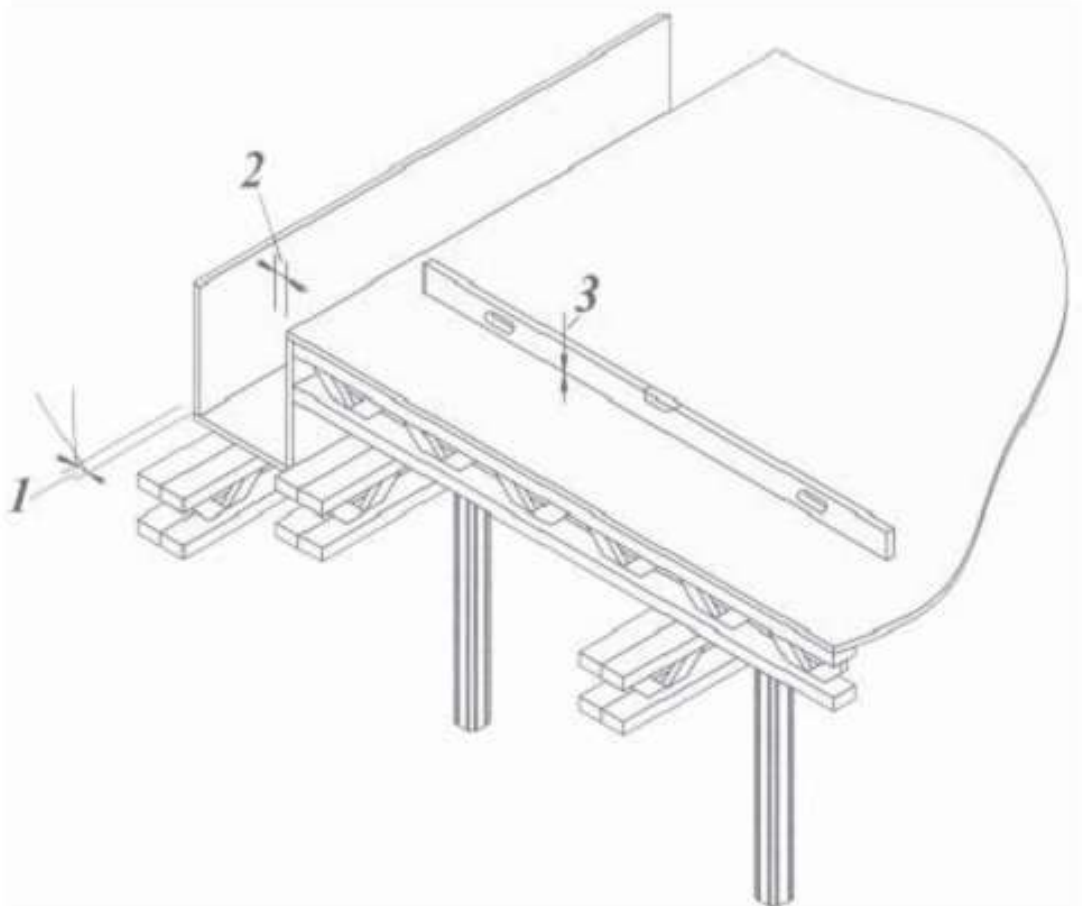

Fig. 4.1. Scheme of operational quality control of the formwork installation work: 1 - permissible deviation of the formwork axes from the design position for beams, purlins ± 10 mm; 2 - deviations of internal dimensions of cross-sections of boxes from the design position of the formwork boxes ± 5 mm; 3 - local irregularities in the formwork 3 mm

The protective layer of the reinforcement is maintained by means of the inventory plastic clips installed in a staggered manner. To align the top mark of the slab being concreted, spatial holders shall be installed or removable beams shall be used whose top level shall correspond to the level of the concrete surface.

Concrete mix is transported to the site by concrete trucks with the concrete being unloaded into a concrete pump. The concrete mixture is fed into the slab structure by means of a concrete pump.

When concreting, walking on the reinforced slab is permitted only on the shields with supports resting directly on the slab formwork.

When pouring the concrete mixture from a concrete pump into the floor slab formwork, the distance between the lower edge of the hose and the surface on which the concrete is laid must not exceed 1.0 m.

The concrete mixture must be laid horizontally in 1.5-2 m wide layers of the same thickness without tearing, with the consistent direction of laying in one direction in all the layers. Laying the next layer of the concrete mixture is allowed before the previous layer of concrete begins to set. The duration of the break between laying adjacent layers of concrete mixture without formation of a working seam shall be determined by the building laboratory.

When concreting flat slabs, working joints can be arranged in any place along the axis of the wall as agreed with the design organization. The surface of the working seam must be perpendicular to the surface of the slab, for which purpose rails are placed in the designated places of interruption of concreting according to the thickness of the slab.

Resumption of concreting in the place of the working seam device is allowed to produce at least 1.5 MPa concrete strength and removal of the cement film from the surface of the seam with a mechanical brush followed by watering.

For compaction of the concrete mixture used deep vibrators (IV-66, IV-47A) or surface vibrators (PV-1, PV-2).

Laying of concrete mixture in the structure is conducted in layers of 15-30 cm with careful compaction of each layer. The most common method of compaction of concrete by vibrating. At the construction site are used internal (deep), external and surface vibrators. Vibrators are driven by electricity (electric vibrators) or compressed air (pneumatic vibrators). Internal vibrators are used to

drive the concrete into solid structures. Surface vibrators compact the concrete mix in floor slabs, floors and other similar structures. External vibrators are used for concreting densely reinforced thin-walled structures. The duration of vibrating at each installation site depends on the plasticity (mobility) of the concrete mixture and is 30-60 seconds. The indication of the sufficiency of vibration is the cessation of settling of concrete and the appearance of cement milk on its surface. Excessive vibration of the concrete mix is harmful, as it can lead to delamination of the concrete. Step of repositioning of internal vibrators - from 1 to 1.5 of the radius of their action.

When a large flow of concrete in large arrays, batch (group) vibrators are used. Large structures are concreted in sections (blocks) with the device of working (construction) joints. Block size in terms of no more than 50-60 square meters. and a height of up to 4 m.

Resume interrupted concreting can be resumed after previously laid concrete mix is complete setting process and the concrete gets a strength of at least 1.2 MPa, about 24-36 hours after laying concrete. For a reliable bond of concrete in the working seam surface of the previously laid concrete thoroughly processed: by notching remove the upper film of mortar and expose a coarse aggregate, blown with compressed air and washed with a jet of water, wiped with wire brushes, in places releasing the bars cleaned of mortar.

During operation the vibrator shall not rest on the reinforcement and embedded parts of the monolithic structure. Do not perform vibro-compaction in the places of direct installation of electrical boxes.

The interval of the internal vibrators shall not exceed one and a half times the radius of its action, the surface vibrators shall be moved so that the vibrator platform at the new position by 50-100 mm overlapped the adjacent section of the vibrator.

The duration of the vibrating at each position has to provide sufficient compaction of the concrete mixture, the main signs of which are the cessation of its settling, the appearance of cement milk on the surface and cessation of air bubbles.

Where the reinforcement, embedded parts or formwork prevent proper compaction of the concrete mixture by the vibrators, the concrete shall be additionally compacted by bayoneting.

During and after concreting, care must be taken to prevent formwork elements and temporary fixtures from becoming entangled in the concrete.

Concrete care must ensure the proper curing temperature is maintained and newly placed concrete is not allowed to dry out too quickly. Freshly laid concrete, first of all, shut down from rain and sunlight (cover with tarpaulin, tarpaulin, bags, sawdust) and systematically watered in dry weather for 7 days the concrete on Portland cement or alumina cement and 14 days in other cements (one-time watering 0.5-1.0 kg / sqm). At air temperatures below 5 ° C watering is not made. Movement of people on the concreted structures and installation on them scaffolding and formwork for the erection of the overlying structures is allowed only after the concrete strength of at least 1.2 MPa.

4.3. Quality control

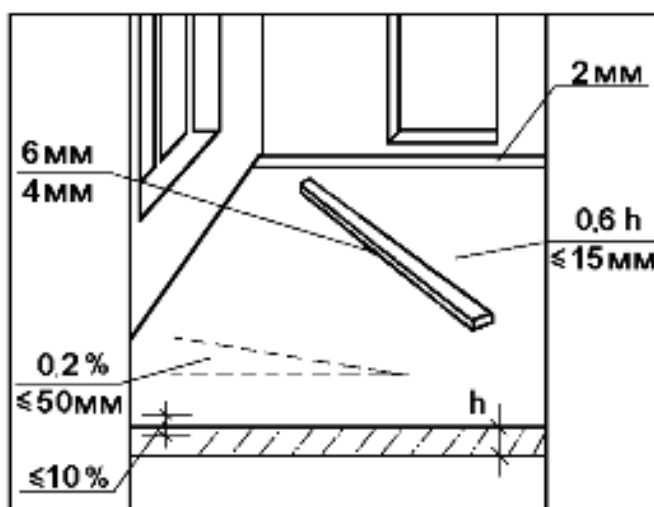

Fig. 4.2. Tolerable deviations

Surface of the pavement from the plane when checking with a two-meter stick should not exceed for:

- asphalt-concrete pavement - 6 mm;
- cement concrete, cement-sand and other types of concrete pavement – 4 mm;
- from the specified slope of the pavement of 0.2% of the corresponding size of the room, but no more than 50 mm;
- on the thickness of the coating - no more than 10% of the design.

The ledges between the coatings and the elements of the floor edging not more than 2 mm.

Table 4.1. Quality control of monolithic columns and walls

| Parameters | Limit deviations |
|---|-------------------------|
| The deviation of the lines of intersection planes from the vertical or design slope for the full height of structures for: | |
| columns supporting monolithic coverings and slabs | 15 mm |
| columns supporting precast beam structures | 10 mm |
| 2. Deviation of horizontal planes over the entire length of the alignment area | 20 mm |
| 3. Local irregularities of the concrete surface when checking with a 2 meters rod, except for bearing surfaces | 5 mm |
| 4. Length or span of elements | ±20 mm |
| 5. Size of the element cross-section | +6 mm; 3 mm |
| 6. Marks of surfaces and embedded items serving as supports for steel or precast reinforced concrete columns and other precast elements | 5 mm |

Not allowed:

- gaps and cracks between baseboards and flooring or walls (partitions);
- potholes, cracks, waves on the surface of the coatings;

- cutting monolithic coatings into separate cards, except for multi-color coatings (with the installation of separating veins).

4.4. Safety precautions

When installing the formwork of floor slabs (coverings) of the monolithic reinforced concrete frame of the building, it is necessary to comply with the requirements of the "Safety Regulations in Construction", paying special attention to the following:

- workers who have been trained, passed an examination for a certain qualification, trained in safe working practices and safety instructions, including at the workplace testing of theoretical knowledge and practical skills for admission to independent work, are allowed to work on the installation and dismantling of formwork;

- installing the formwork, it is prohibited to interrupt the installation of loose elements or their parts;

- disassembling the formwork of concreted structures shall be permitted only with the permission and under the supervision of the foreman or the work supervisor;

- it is prohibited to store the dismantled elements of the formwork at the workplace. The materials from the disassembled formwork must be immediately sorted out, with the nails removed, and delivered to the storage site by crane;

- carpenters, installers shall work in appropriate protective clothing and use personal protective equipment;

- when operating electrified hand tools at the construction site must comply with all general safety regulations and special requirements under the rules of safe operation, specified in the passport and operating instructions for each hand-held machine;

- when the crane delivers loads to the storage area, the load must not be carried over the areas where construction work is in progress;

- comply with the requirements of the instructions.

When performing work on the construction of the slab formwork (coverings) of the monolithic reinforced concrete frame of the building, the following hazardous production factors shall be taken into account:

- falling of people from height;
- electric shock to people.

To prevent people from falling from height when receiving goods and works, workers shall be secured with a safety harness, the securing points shall be indicated by the foreman or the operator; when working on the slab (coating), arrange fencing to prevent the worker from falling out.

To avoid electric shock to people: repair work, grounding, connection to the mains electrical equipment in this process chart provides only the electrician on duty, having a group of tolerance of electrical safety not lower than II.

When constructing a monolithic slab:

Concrete worker is obliged to work in the work clothes and footwear issued to him and keep them in good working order. In addition, he must have the necessary protective equipment for work and always use them.

Before you start work, workplaces and passages to them must be cleaned from foreign objects, debris and dirt, and in winter - from snow and ice and sprinkle them with sand.

It is prohibited to work in the area where there are no fences of open wells, pits, manholes, openings in the floors and openings in the stacks. At night, in addition to fencing in dangerous areas, light signals must be displayed.

In case of insufficient lighting of the workplace, the worker shall be obliged to inform the foreman.

It is prohibited to screw in and out live electric lights, and carry temporary electrical wiring to the concrete worker. This work must be performed by an electrician.

Staying in the zone of operation of lifting mechanisms, as well as standing under the lifted load is prohibited.

Concrete worker is not allowed to turn on and off mechanisms and signals, to which he is not related.

Machines, power tools and lighting lamps may only be switched on by means of circuit breakers, etc. No worker is permitted to connect or disconnect live wires. If it is necessary to extend wires, an electrician must be called in.

To avoid electric shock, do not touch poorly insulated electrical wires, exposed parts of electrical devices, cables, busbars, circuit breakers, light bulb sockets, etc.

Before starting the equipment, check the reliability of guards on all exposed rotating and moving parts of the equipment.

If detected malfunction of machinery and tools with which the concrete worker, as well as their fences, the work should stop and immediately report it to the master.

Upon receipt of the tool must ensure that it is in good condition: a defective tool shall surrender for repair.

When working with hand tools (scrapers, bushards, shovels, rammers), it is necessary to monitor the serviceability of the handles, the tightness of the tool tips on them, as well as to ensure that the working surfaces of the tool has not been shot down, blunted, etc.

It is prohibited to work with mechanized tools from attached ladders.

Electrified tools and the power supply cable must be reliably insulated. Upon receipt of the power tool, the wire insulation must be inspected externally. When working with the tool, make sure that the power supply cable is not damaged.

At the end of the work mechanized tools must be disconnected from the mains and handed over to the store room.

When bringing materials-fillers and concrete mixture, workers should know that the maximum permissible load:

- for women - 20 kg
- 10 kg for female teenagers
- 16 kg for male teenagers

Adolescents under the age of 16 years are not allowed to work as a load carrier.

When moving construction cargo in wheelbarrows its weight must not exceed 160 kg.

To avoid colds, all openings in the premises shall be sealed with temporary shields.

During the cold season, rooms specially designated for heating should be used. Heating in boiler rooms, heating wells, bunkers, as well as on calorifiers is prohibited.

In the event of an accident with a fellow worker, first aid must be given and the foreman or foreman must be informed.

4.5. Installation of hinged ventilated façade

The ventilated facade system consists of the following structural elements:

- the fastening brackets, attached to the wall of the facade being clad, for fixing the vertical rails
- a thermal insulation layer, which insulates and insulates the walls of the building
- horizontal and vertical rails, which are part of the frame
- cladding layer - the basic fencing and decorative facade structure

Work on the device of ventilated facade shall be performed at the temperature from minus 15 to plus 25°C. When performing work in adverse weather conditions, workplaces should be protected with awnings or shades.

The following issues are considered as part of the technological chart:

- preparatory works
- bracket installation
- facade insulation
- supporting frame arrangement
- exterior cladding arrangement

The mode of operation is taken from the condition of the optimal pace of work processes, with a rational organization of the workplace, the clear distribution of responsibilities between the workers in the team, taking into account the distribution of labor, the use of mechanized tools and equipment.

All works on the facade system are performed in accordance with the requirements of the design documentation, PPR, and this TK.

Prior to the start of installation work, the following work must be completed:

- General construction work on the facades to be insulated is completed
- On the basis of the execution survey perform measurement drawings of the building facade sections, which indicate:

a) deviation of lines of the planes of load-bearing structures, walls, ceilings, parapets

b) peculiarities of the relief of the cladding structures and adjoining elements of the facade, overhangs, transitions, window and door openings, architectural features, ventilation grills, stained glass panels, ledges, junctions to systemic structures

c) deviations in curvature of radial structures of mounted facades and complex structures of the building

- marking of the facade has been made
- lighting fixtures must be removed from facades, sill drains, skylights or light floodlights must be removed

To install the system, the scaffolding must be prepared.

When installing the scaffolding, the props must rest on steel shoes and be anchored to the facade with anchors through one node vertically and horizontally. The gap between the working platform and the cladding must not exceed 150 mm.

Before the start of work on the installation of ventilated facades with facade cassette cladding, the materials, tools and equipment must be prepared in accordance with the specifications. Quality control of materials is the responsibility of the contractor. Quality control and acceptance of the work performed shall be carried out in accordance with the existing regulatory and technical documents.

Prior to the start of work on installation of ventilated facades, tents shall be prepared to protect the insulation and building structures from precipitation, safety canopies, fenced hazardous areas, installed, tested and accepted means of scaffolding.

To perform the work on the installation of the system on one work site, a team was hired consisting of:

- Construction installer, 5th category - 1 person.
- Construction installer, 4th category - 1 person.
- one construction installer of the 3rd category - 1 person.

It is necessary to train the workers in the methods of work execution, to familiarize them with the organization of the site, this technical sheet, to instruct them in safety engineering and safe working methods.

To perform work on the installation of the system, the building is divided into seating areas and determine the order and sequence of movement of installers from one area to another.

The installation of the system begins with the marking of the facade. It should be performed as a separate stream on the entire front of the work.

Geodetic surveying and marking of the facade must be carried out with geodetic devices, high-precision levels with a large base, plumb lines. The marking of the installation locations of the brackets of the subsystem must be carried out in strict accordance with the project documentation. Errors made in the performance

of markings will inevitably lead to deviations of the system parameters. Correctness of the marking should be constantly monitored.

Before the markings are made, the overall dimensions of the facades should be checked and compared with the data given in the drawings, and the dimensional chains given in the drawings and their reference to the characteristic elements of the facade wall should also be checked. The markings are drawn on the surface of the wall with optical instruments and fixed with indelible paint.

Placement brackets on the facade of the wall made, as a rule, with a pitch in the range: vertically from 600 to 1200 mm horizontally from 350 to 800 mm, indenting from the edge of the wall at least 100 mm to the axis of the bracket.

After marking the facade in the places where the brackets are mounted, drill holes for anchors and mount the brackets to the wall. To reduce heat loss and eliminate the "cold bridge" in the areas where the brackets adjoin to the wall under them install paronite gasket. Drilling should be carried out with an electric drill on the marks.

The use of fasteners other than those specified in the project documentation is not allowed.

The diameter of the holes must match the type of dowel (anchor) used, the depth of the holes must exceed the length of the dowel in the wall by at least 15 mm. In cases where the basis is masonry, you can not install dowels in the joints of masonry, and the distance from the center of the dowel to the spoon joint must be at least 35 mm, and from the dowel - 60 mm.

The design of the brackets allows leveling the plane of the crate to 30 mm to create an even surface for the cladding.

Brackets are attached to the wall with anchors, selected in accordance with the material of the wall, using the washer. Fastening is carried out with one or two anchors (according to the calculation).

The wall on which the insulation boards are installed must be protected against moisture.

Installation of insulation boards is carried out from the bottom upwards. Thermal insulation boards must be installed tightly to each other to avoid white voids in the joints. If it is impossible to avoid voids, they must be sealed with the same material.

Plastic dowel anchors of disc type with expansion rods are used for fixing the insulation boards to the base. The length of dowels depends on the thickness of the insulation, the consumption of at least 7 pieces per 1 m². To install the dowel anchors, the board must be pre-cut and a hole must be drilled in the wall.

The diameter of the drilled hole should match the outer diameter of the dowel anchor sleeve.

In case of using the wind-damp-proof membrane, the installed boards of insulation are first fixed with 2 dowels (each board) and only after covering with the membrane, the other boards are installed, as stipulated by the project. The film panels are installed with 100 mm overlaps.

Fixing insulation boards fixed with dowel anchors must be handed over to the Customer with drawing up an act of hidden works.

Mounting the frame can be done in two ways:

Horizontally oriented profile must be fixed to the brackets with two self-tapping screws SMESH 2-4,8x28 or with rivets. The design of the brackets allows leveling (straightening) of horizontal purlins up to 30 mm to create an even surface for the cassettes. If this is not enough, it is necessary to install brackets of a different length.

On the formed horizontal purlins it is necessary to mount the basic vertical purlins of the U-shaped profile using self-tapping screws SMESH2-4.8x28. The main vertical purlins are installed along the vertical joints of facade boards. The distance between the profiles must be kept accurately. If the width of the board exceeds 700 mm, you have to install additional intermediate profiles between the basic profiles.

The compensation gap between the profiles must be 6-15 mm. Brackets are installed on both sides of the expansion gap at a distance of:

- not more than 450 mm for vertical profiles;
- not more than 300 mm for horizontal profiles.

On the vertical purlins are mounted shaped elements. The visible part of the main profiles of the vertical purlins is color-coated or covered with a decorative colored band.

Along the bottom row of panels, install the horizontal joint strip, which is attached to the vertical rail with self-tapping screws or rivets.

Window and door openings are equipped with galvanized steel fittings with a polymer coating that form boxes, which are fastened to window or door units with self-tapping screws or rivets with a pitch of 300-500 mm on one side and to the framing of the opening with Z-shaped profiles on the other side.

Complex end trims, rebates with dimensions according to the project or external corner trims (30x30, 50x50, 75x75 mm) are also used to frame window and door openings.

On the bottom of the window frame, a window drainage strip with dimensions according to the project is installed.

Quality control, signing of the acts on the hidden works and the act of final acceptance of the cladding structures shall be performed by the following officials legally responsible for the quality of work.

- The engineering and technical personnel of the executor (foreman, site manager), who must ensure the proper execution of all works, not to allow the violation of technology and to promptly correct committed errors, to organize a collective examination and acceptance of hidden works with the drawing up of acts;

- designers - the authors of the project, which shall ensure the proper implementation of the design decisions on the composition and quality of

implementation. For this purpose, author's supervision and logging shall be organized at the construction site;

- A representative of the technical supervision shall regularly monitor the accuracy of implementation of design solutions, compliance with the technology of work execution, participate in quality control and acceptance of hidden works A representative of the technical supervision of the customer has the right to prohibit the work in case of detection of circumstances that cause deterioration of quality

The quality of input materials and component parts must be guaranteed by the supplier. The parameters of the supplied parts shall be specified in their datasheets and comply with the requirements of the project The works producers shall observe the rules of storage, transportation and use of materials.

When accepting the cladding and insulation of the glass must be carried out staged acceptance quality control, the quality control service, implementation of each of the structural elements, with a record of the log and drawing up acts on the hidden work. The following works, structures and structural elements are subject to mandatory intermediate inspection and acceptance with drawing up of an act on the hidden works:

- The prepared surfaces of the walls to be cladding
- supporting frame
- thermal insulation and fastening elements
- cladding with facade cassettes (final act)

The final inspection of the ventilated facade cladding with facade cassettes is performed by all persons responsible for the quality in the presence of the customer's representative and is executed by signing the act of acceptance. The following documents must be attached to the act of final acceptance:

- design documentation:
- documents certifying quality of materials
- acts of hidden works

- the log of the works indicating the temperature and weather conditions under which the work was performed.

Work must be carried out by specially trained workers under the direction and control of engineering and technical personnel. Workers who have undergone a medical examination, a set of briefings on the rules of safety and fire safety should be allowed to work.

About the briefings should be made notes in special logs with the signatures of the instructed. Journals shall be kept at the site or in the construction (repair) organization.

All workers must be trained in the rules of firefighting and ways of working with primary firefighting means.

Workers must have protective clothing, respirators, helmets, safety belts, harmless detergents, protective pastes, etc., and be appropriately qualified for the work being performed. All work must be performed from the inventory of tools and equipment.

It is not allowed to be at the construction site or at the storage site of the elements without helmets.

The works on mounting, stacking, loading and unloading of long metal structures (cladding panels) shall be performed with gloves on.

All work with mineral wool insulation shall be performed with safety glasses.

Workers who have received special training shall be allowed to work with mechanized hand tools and mechanisms. The use of defective mechanisms and defective mechanized hand tools is unacceptable. Before starting a shift, it is necessary to check the serviceability of the means of support, mechanisms, tools and appliances. All detected defects must be eliminated before the start of work. If any malfunctions are detected in the mechanisms, auxiliary aids and other devices, the work shall be stopped immediately.

Devices designed to ensure the safety of workers and convenience of work (cradles, scaffolding) must meet the requirements and operating instructions of the manufacturers.

In the places where workers are lifted to the scaffolding must be posted posters indicating the magnitude and layout of the loads according to the PPP and instructions for their use.

Small tools installed on the construction site with a voltage greater than 42 V must be grounded. In rain, snow, work with electromechanisms and tools on the roof is prohibited. Switches and starters shall be placed in lockable covers. Electrical wiring to the machines and tools shall be insulated and grounded and enclosed in special hoses, and the connections shall be carefully insulated.

No bystanders are allowed in the work area.

When carrying out the work materials should not fall into the operated premises, balconies, loggias, passages and passageways. If necessary, protective and sheltering materials shall be used.

Storage and storage of materials on the means of support, as well as in basements, stairwells, passages and other places accessible to outsiders is not allowed.

Before work commences, the construction site shall be prepared in accordance with existing standards and regulations, fenced, equipped with temporary buildings, structures, warehouses, utilities, etc. Storage areas for cylinders with flammable gases and inflammable materials must be marked and prepared.

It is forbidden to carry out any work outside the construction site.

The location of any temporary facilities in the fire breaks is forbidden, on the operated passages and passages the temporary facilities shall be located at a distance of at least 18 m from other buildings and constructions (except where a larger fire break is required by other regulations) or near the fire walls. Separate block-container buildings may be located in groups of not more than 10 in a group

and with an area of not more than 800 m² the distance between groups of these buildings and from them to other structures should be not less than 18 m.

When carrying out work on the insulation of the enclosing structures on an area of more than 1000 m², using flammable or combustible insulation, for firefighting purposes, it is necessary to provide a temporary fire fighting water supply system. The distance between fire hydrants should be taken from the condition of water supply to any point by at least two jets with a flow rate of 5l/s each. The building and living quarters shall be provided with fire extinguishing means at the rate of two fire extinguishers per 100 m² of insulated surface at the same time, and means of communication to call the fire department in case of fire.

It shall not be allowed to use primary fire extinguishing means for household and other purposes not related to fire fighting. Fire extinguishers shall always be kept in good working order, and shall be periodically inspected, tested and recharged in a timely manner. When placing fire extinguishers, it is necessary to comply with the condition that the distance from the possible seat of fire to the location of the fire extinguisher shall not exceed 20 m. In winter (at temperatures below 1 ° C) fire extinguishers shall be stored in heated rooms, the doors of which shall be inscribed "Fire extinguishers".

It shall be prohibited to perform cladding and insulation works using combustible materials together with welding and other works using open fire.

It shall be prohibited to smoke and use an open flame in places where combustible materials are stored and used.

Standard safety signs shall be posted when laying combustible materials, as well as when using equipment with an increased fire hazard.

At the place of work, the amount of combustible materials (insulation) shall not exceed the shift requirement. At the end of the shift, the working places shall be inspected and brought to a fireproof condition. It is forbidden to leave unused combustible material inside and on the coverings of the building, on the means of support, in the fire breaks.

Upon detection of a fire or signs of burning (smoke, smell of burning, temperature increase, etc.) it is necessary to immediately notify the fire department, take all possible measures to evacuate people, extinguish the fire and ensure the safety of material resources.

5. Environmental protection

5.1. Atmospheric air condition

Air pollution was monitored by the Central Geophysical Observatory at 16 stationary posts located in 8 districts of the capital. In 2017, 80367 samples were collected and analyzed to determine air pollution. At PSZ No. 10 and PSZ No. 13, only carbon monoxide was monitored throughout the year due to the posts being disconnected from the electricity supply.

At all stationary stations, the content of the main pollutants was determined - suspended solids, sulfur dioxide, carbon monoxide and nitrogen dioxide, and at one station - the content of soluble sulfates and nitrogen oxide. The content of specific substances such as hydrogen sulfide, phenol, hydrogen fluoride, hydrogen chloride, ammonia, formaldehyde, iron, cadmium, manganese, copper, nickel, lead, chromium, and zinc was monitored at separate stations, taking into account emissions from industrial enterprises located near the IAF, as well as in the areas of the city's busiest highways.

In 2017, the overall level of air pollution in Kyiv was assessed as high according to the Atmospheric Pollution Index (API). In general, the average daily maximum permissible concentrations (MPCs.d.*) in Kyiv were exceeded by 3.0 times for nitrogen dioxide, 2.0 times for formaldehyde, and 1.3 times for nitrogen oxide and phenol. These are substances of hazard classes 2 and 3 and those that polluted the city's air to the greatest extent throughout the year.

The average annual concentrations of suspended solids exceeded the MPCs at Bessarabska Square (PPS No. 7) and Peremohy Avenue (PPS No. 11 - Sviatoshyn metro station) by 1.3 times, while at other stations they were at the level of 0.7-0.9 MPCs. In general, the average annual concentration of suspended solids in the city was 0.8 MPCs.d. The maximum concentrations at the city's checkpoints were in the range of 0.2-0.6 MPCm.a.

The nitrogen dioxide content exceeded the respective MPCs at almost all posts in terms of average annual and maximum concentrations. The highest average annual nitrogen dioxide concentrations were observed at the stations located near highways with heavy traffic: in the area of Bessarabska Square - 3.8 MPCELS, on Demiiivska Square, Peremohy and Obolonsky Avenues - 3.5 MPCELS. At other stations, the average annual concentrations were in the range of 2.3-3.3 MPCs, and at Nauky Avenue - 0.8 MPCs. The maximum one-time concentrations of nitrogen dioxide were recorded in July at Demiiivska Square at 1.8 MPCEL, Inzhenera Borodina Street (PPS No. 4) - 1.7 MPCEL, Peremohy Avenue - 1.6 MPCEL, in June at Bessarabska and Peremohy Squares - 1.6 MPCEL, at Nauky Avenue - 0.5 MPCm.a. The frequency of exceedance of the maximum one-time MPC of the total number of observations in the city was 8.6% (last year - 10.1%); the highest frequency of occurrence was recorded at the PPS No. 7 - 23.3%, at the PPS No. 11 - 16.4%, at the PPS No. 20 - 15.5%.

The average annual content of nitrogen oxide (determined only at PSP No. 20) was 1.3 MPCs.d., the maximum was 0.4 MPCm.a.

In July-November 2017, the phenol content in the air of Kyiv increased significantly: the average monthly concentrations during this period were 2.0-3.3 ppb, the maximum - 1.0-2.0 ppb, the average phenol content at the posts was 1.0-1.3 ppb. The maximum concentrations were recorded in July at Oleksandr Dovzhenko Street (PPS No. 2) and Kaunaska Street (PPS No. 9) at the level of 2.0 MPCm.a., while at other posts they were in the range of 1.3-1.7 MPCm.a: The frequency of cases of exceeding the maximum one-time MPC of the total number of observations in the city was 4.5% (no exceedances were recorded last year); the highest frequency of exceedances was recorded at PSZ No. 9 and PSZ No. 8 - 5.2 and 5.0%, respectively.

The formaldehyde content in the air was measured at 13 stations. The average annual concentrations of this impurity at almost all stations where it was determined exceeded the average daily MPC by 1.7-2.7 times. The highest average

annual formaldehyde content was observed on Bessarabska Square and Peremohy Avenue - 2.7 MPCs; the lowest - on Nauky Avenue - 0.7 MPCs. One-time concentrations of formaldehyde were in the range of 0.3-0.7 MPCm.a., the highest of which were observed in August.

The average annual concentrations of hydrogen sulfide at the three stations where this impurity was measured were 0.001-0.002 mg/m³, with the maximum concentration of 0.004-0.005 mg/m³ (0.5-0.6 MPCm.a.).

The average annual content of other specific impurities in the city as a whole was as follows: hydrogen fluoride - 0.8 MPCs.d., hydrogen chloride - 0.4, ammonia - 0.2 MPCs.d.

The content of sulfur dioxide at the posts and in the city as a whole did not exceed the level of the relevant sanitary and hygienic standards. The average annual concentrations were in the range of 0.2-0.6 MPCs.d., the maximum concentrations were at the level of 0.1-0.2 MPCm.a.

For carbon monoxide, the highest average annual concentrations were recorded in the areas of Bessarabska and Demiiivska squares (PSZ No. 20) - 1.6 and 1.4 MPCs, respectively: at five other posts, the average annual concentrations were 1.0-1.2 MPCs. In general, the average annual concentration of carbon monoxide in the city was 0.9 MPCEL. The maximum concentrations exceeding the MPCs were observed at all stations, except for the "green zones" - the territory of the Expocenter of Ukraine (PSZ No. 15) and 37 Nauky Avenue (meteorological station of the Central Civil Defense Organization). The highest one-time concentrations were observed in summer, in August: on Peremohy Avenue - 2.8 MPCm.a.y, Akademika Strazheska Street (intersection with Vaclav Havel Boulevard. PSZ No. 1) - 2.6 MPCm.a. Bessarabska Square - 2.4 MPCm.a. The frequency of cases of exceeding the maximum one-time MPC of the total number of carbon monoxide observations was 24% on Bessarabska Square, 11.3% on Demiiivska Square, and 9.6% on Peremohy Avenue; in the city it was 4% (last year - 0.2%). The data on soluble sulfates and hydrogen sulfide in multiples of MPCs

are not presented due to their absence for these substances. The maximum concentrations of the above-mentioned pollutants did not exceed the relevant sanitary and hygienic standards, with the exception of hydrogen chloride, whose maximum concentrations in July-August at all city posts reached 1.1-1.2 MPCm.a.

The content of heavy metals was well below the permissible levels. In 2017, the average annual concentrations of cadmium, iron, manganese, copper, nickel, lead, chromium and zinc at all posts and in the city were at the level of 0.0-0.1 MPCs.d.

In the annual course of average monthly concentrations, an increase in sulfur dioxide was noted in February-March, carbon monoxide in July-August, and phenol, nitrogen oxide, and hydrogen chloride in August. A slight increase in hydrogen fluoride was recorded in June and August. Average monthly concentrations of nitrogen dioxide exceeded the MPCs by 2.8-3.5 times throughout the year, with the most polluted air from May to August, with a maximum in May. The formaldehyde content was also elevated throughout the year, with the highest average monthly concentrations (at 3.0 MPCs) recorded from June to August. The content of suspended solids and ammonia remained almost unchanged throughout the year.

According to the Air Pollution Index (API), a "high" level of air pollution was observed throughout the year, with a "very high" level recorded in August. Weather conditions also contributed to this.

August 2017 in Kyiv was hot in terms of temperature. According to the weather station of the Central Geophysical Observatory, the average monthly temperature in August in Kyiv was +22.4°C, which exceeded the climate norm by 3.8°C. The air temperature exceeded 30°C for 16 days in August.

In the first and second decades of August, meteorological conditions in Kyiv were favorable for the accumulation and retention of harmful impurities in the surface air layer. The Ukrainian Hydrometeorological Center issued 3 storm warnings about high levels of air pollution in Kyiv: from July 31 to August 5,

August 8-12, and August 16-21, 2017. The increase in air pollution during these periods was due to the anticyclonic nature of the weather, heat, and low winds in the surface air layer.

During this period, the highest concentrations of pollutants in the atmosphere were recorded at stationary observation posts. In particular, the average daily concentrations of formaldehyde at some stations reached 4.9-5.3 MPCs, nitrogen dioxide - 4.0-4.6, phenol - 3.7-4.5, carbon monoxide - 2.8-3.2, nitrogen oxide - 1.4-1.6, hydrogen fluoride - 1.1-1.2 MPCs.

Due to such weather conditions, as well as emissions from vehicles and emissions from asphaltting and repair work on many city roads, in August, an increase in air pollution by almost all impurities was observed and the INR increased in the city as a whole and at four posts (PSZ #2, 17, 7, 9) to the "very high" level.

In general, according to the average annual concentrations of pollutants in 2017, the level of pollution at 11 checkpoints in the city was assessed as high. The location with the highest air pollution was Bessarabska Square. Other locations with high levels of pollution were Peremohy Avenue (Sviatoshyn metro station), Demiiivska Square, Obolonskyi Avenue, and Oleksandr Dovzhenko Street (Shulyavka metro station). Kaunaska Street, Akademika Strazheska Street (intersection with Vaclav Havel Boulevard), Semena Skliarenka Street, Peremohy Square, Lesia Ukrainka Boulevard, and Popudrenka Street (Chernihivska metro station). An increased level of pollution was recorded at Hydropark (near the metro bridge and Brovarskyi Avenue) and on Inzhenera Borodina Street (near the DVRZ). The least polluted area (low level) was the area of Nauky Avenue (near the weather station).

Compared to the previous year, the level of air pollution in the city according to the Index of Air Pollution increased slightly (from 8.3 to 9.1) and was determined by the concentrations of nitrogen dioxide, formaldehyde, nitrogen oxide, phenol, and hydrogen fluoride. Compared to 2016, the average annual

concentrations of phenol, carbon monoxide, and hydrogen fluoride increased significantly. The content of other impurities remained almost unchanged.

5.2. Formation of an ecological network

Ensuring sustainable, ecologically balanced development of the city, increasing its natural resource potential, preserving valuable natural areas, biological resources located there, and the genetic fund of flora and fauna require maintaining an optimal balance between areas that are intensively exploited and those subject to special protection and restoration regimes. To ensure this balance, an ecological network is being formed both in Kyiv and in Ukraine.

An ecological network is a single territorial system that is formed to improve conditions for the formation and restoration of the environment, increase the natural resource potential of the territory of Ukraine, preserve landscape and biodiversity, habitats and growth areas of valuable species of flora and fauna, genetic stock, animal migration routes through the combination of territories and objects of the nature reserve fund, as well as other areas of particular value for environmental protection and in accordance with laws and international obligations.

The Law "On the Ecological Network of Ukraine" defines the list of land categories that are included in the structural elements of the ecological network:

- a) territories and objects of the nature reserve fund;
- b) lands of the water fund, wetlands, water protection zones;
- c) lands of the forest fund;
- d) shelterbelts and other protective plantations that are not classified as forest lands;
- e) lands of recreational use with their natural resources

f) lands of recreational purpose used for organization of mass recreation and tourism and holding sporting events;

g) other natural territories and objects (areas of steppe vegetation, pastures, hayfields, stone placers, sands, salt marshes, land plots within which there are natural objects of special natural value);

h) land plots on which natural plant communities listed in the Green Book of Ukraine grow;

i) territories that are habitats or growth areas of species of flora and fauna listed in the Red Book of Ukraine;

j) partially agricultural land of extensive use - pastures, meadows, hayfields, etc.; and

k) radioactively contaminated land that is not used and is subject to separate protection as natural regions with a separate status.

These areas ensure the conservation of the most valuable and typical components of landscape and biodiversity in the region.

There are biosphere, continental, national, regional (oblast), and local ecological network levels. The regional level is key, as it ensures the formation of a real territorial ecological network system.

In pursuance of the Law of Ukraine of 21.09.2000 No. 1989-III "On Approval of the National Program for the Formation of the National Ecological Network for the 2000-2015", Kyiv has developed measures that provide for the creation of new nature reserves, inventory of natural complexes and objects of the nature reserve fund (NRF), creation of an automated system for maintaining the state cadastre, development of a regional scheme for the formation of an ecological network and development of a scientific model for organizing environmental monitoring in the NRF.

References

1. ДБН В.2.2-15-2005. Будинки і споруди. Житлові будинки. Основні положення: на зміну СНиП 2.08.01-89 та ДБН 79-92: чинний з 2006-01-01. – К.: Мінбуд. України, 2006. – 65 с.
2. ДБН В.2.2-9-2009. Будинки і споруди. Громадські будинки та споруди. Основні положення: на зміну ДБН В.2.2-9-99: чинний з 2009-07-01. – К.: Укрархбудінформ, 2009. – 47 с.
3. ДБН В.2.6-31:2006. Конструкції будинків і споруд. Теплова ізоляція будівель: на зміну СНиП II-3-79: чинний з 2007-04-01. – К.: Мінбуд. України, 2006. – 65 с.
4. ДБН В.2.6-31:2006. Теплова ізоляція будівель. Зміна №1 [Текст] // Інформаційний бюлетень МРУ. – № 5. – 2013. – С. 3–11.
5. ДБН В.1.1-7-2002. Пожежна безпека об'єктів будівництва: на зміну СНиП 2.01.02-85: чинний з 2003-05-01. – К.: Держбуд України. – 2003. – 43 с.
7. ДБН В.1.2.-2:2006. Система забезпечення надійності та безпеки будівельних об'єктів. Навантаження і впливи: чинний з 2007-01-01. – К.: Мінбуд України, 2006. – 56 с.
8. ДСТУ Б В.2.6-101:2010. Методи визначення опору теплопередачі огорожувальних конструкцій. – К.: Мінбуд. України, 2010. – 84 с.
9. ДБН Б.2.2-12:2019 «Планування і забудова територій», чинний з 1 жовтня 2019 р.
10. ДБН В.2.1-10:2018. «Основи і фундаменти будівель та споруд. Основні положення». – К.: Держбуд України, 2018.
11. ДБН В.1.1-7-2016 «Пожежна безпека об'єктів будівництва». Чинний від 2017-06-01 – 38с.
12. ДБН А.3.1-5-2016 «Організація будівельного виробництва». – К.:2016.- 49 с.

13. ДБН А.3.2-2:2009 ССПБ. «Охорона праці і промислова безпека в будівництві. Основні положення».
14. ДБН В.1.2-14:2018 «Загальні принципи забезпечення надійності та конструктивної безпеки будівель і споруд»/ Мінрегіонбуд України. – Київ, 2018.
15. Гетун Г.В., Румянцев Б.М., Жуков А.Д. Системи ізоляції будівельних конструкцій. Навчальний посібник. – Дніпро: Журфонд – 2016 р. – 676 с.
16. ДБН В.2.6-163:2015. «Сталеві конструкції. Норми проектування, виготовлення і монтажу».
17. ДБН В.2.6-160:2010. Конструкції будівель та споруд. Сталезалізобетонні конструкції. Основні положення. – Мінрегіонбуд України. – Київ. – 2010. – 210 с.
18. Horb O., Davidenko Y., Skurupiy O., Mytrofanov P. (2020). Application of Bonding Concrete to Reinforcement Using Adhesives in Steel Concrete Composite Structure. Proceedings of the 2020 session of the 13th fib International PhD Symposium in Civil Engineering (Paris, France, August 26-28, 2020). PP. 2 – 9.
19. Lapenko, O., Baranetska, D., Makarov, V., Baranetskyi, A., 2020. Designing of Structural Construction and Orthotropic Slabs from Steel Reinforced Concrete. MSF 1006, 173–178.
20. R. Hunter, A. Vizán, J. Pérez, J. Möller, J. Leyrer, L.F.M. da Silva. Effect of the structural reinforcement of composite adherends on the mechanical strength of adhesive joints. Materials Science & Engineering Technology. 2017. Vol. 48, № 6. P. 546-555.
21. Barabash, Maria & Pysarevskyi, Bogdan & Bashynskyi, Yaroslav. (2020). Material Damping in Dynamic Analysis of Structures (With LIRA-SAPR Program). Civil and Environmental Engineering. 16. 10.2478/cee-2020-0007