

INTRODUCTION

Mechanics is a science about motion and strained state of different physical objects. It consists of theoretical and applied parts that are connected with each other. Theoretical mechanics deals with determining general appropriatenesses of mechanics ignoring their specific application. Applied mechanics deals with motion and strained state of real technical objects such as machines, constructions and devices.

The theory of mechanisms and machines is a component part of the applied mechanics. It is a science about general research methods of mechanisms and machines characteristics and designing their diagrams. In the theory of mechanisms and machines these researches are being developed independently on a mechanism functions irrespective of if it is a part of aircraft or car or any other machine. In this case only the most general and essential mechanism indications are considered.

In the process of engineering development the definitions of a machine and a mechanism were changed. Now their definitions are the following.

Machine is a technical device in which mechanical motions are performed for transforming energy, materials and information in order to replace of facilitate people' physical and mental work. There exist power, technological, transport and information machines.

Power machines transform energy from one form to another (engines, generators, etc.). Technological machines serve for changing forms, sizes and properties of initial materials (metal cutting machine tools, rolling mills, etc.). Transport machines serve to carry cargos, people and other objects in the space with needed velocity (airplanes, electric locomotives, lifts, etc.). Information machines transform input information in order to control, regulate and manage motion.

In machines the working process is connected with carrying out mechanical motions. Mechanical motions can be performed by different mechanisms.

Mechanism is a system of joined bodies serving to transform motions of one or few solid bodies into necessary motions of other solid bodies.

If mechanism contains liquid or gas besides solid bodies we will deal with hydraulic or pneumatic mechanisms. But if there are no transforming motions in technical devices they cannot be a mechanism.

The tasks of the theory of machines and mechanisms are very different. The most important of them are analysis and synthesis of mechanisms.

Analysis of a mechanism consists of researching mechanism properties (kinematic, dynamic, structural) according to given diagram.

Synthesis of a mechanism is developing mechanism diagram and determining its parameters according to given properties.

The theory of machines and mechanisms consists of the following basic parts: structure, kinematics and dynamics of mechanisms. There are tasks of analysis and synthesis in each part.

Chapter 1

STRUCTURAL ANALYSIS OF PLANE MECHANISMS

1.1. Main definitions

A mechanism or a machine consists of solid bodies that are movable connected with each other. If a solid body is a part of a mechanism and is movable connected with other bodies, then it is a link. For example, an internal-combustion engine consists of such links as crankshaft 1, con-rod 2, piston 3 and cylinder 4 (Fig.1.1). Every link can perform certain motion but motions of all links are connected with each other.

A solid body that is a part of a link is called an element. It is the simplest part of a mechanism made without any assembly operations. For example, link 2 consists of a body of the con-rod, a pressed bushing, the con-rod cover and screws with washers and cotter pins. But all elements have to be firmly connected with each other and move as single solid body.

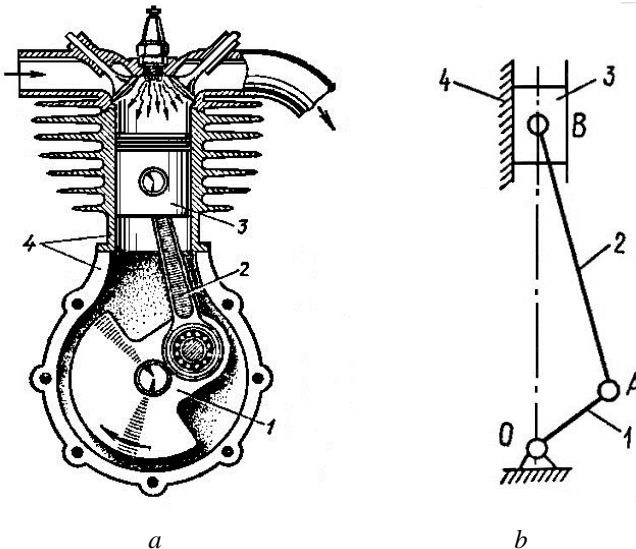

Fig.1.1. The mechanism of the internal-combustion engine (a) and its diagram (b)

Links of a mechanism may be movable and immovable. Immovable link is called a fixed link. As rule, a fixed link consists of some elements. If a machine is movable, then the fixed link is connected with its frame. All other links moving relative to a fixed link or relative to each other are called movable. For example, in the internal-combustion engine movable links are the crankshaft, the con-rod, the piston and the cylinder is considered as the fixed one.

Thus, every mechanism or machine always has one immovable link and one or some movable links. Movable links may be input and output. Input link is a link that receives motion to transform it into necessary motion of other links by a mechanism. Output link is a link that makes motion for carrying of which a mechanism serves. All other links of a mechanism are called intermediate or joined links.

As a rule, a mechanism has one input and one output. There are also mechanisms that have some input and output links. For example, a car differential gear has one input, that receives motion from the engine and two outputs that are joined with rear wheels.

Besides, movable links are divided into driving links and driven links. Driving link called a driver is a link that has positive elementary work of applying external forces. A driven link is called a follower. It is a link that has negative elementary work of applying external forces.

Links of mechanisms and machines are connected with each other in a determined way. Movable joint of two links being in contact is called a kinematic pair. For example, in the internal-combustion engine crankshaft 1 and fixed link 4 make up the kinematic pair. The pair permits only one rotatory movement of link 1 relative to link 4. This kinematic pair is turning one. Crankshaft 1 and con-rod 2 form the turning pair too, because it permits only rotatory motion of the con-rod relative to the crankshaft. Just so con-rod 2 and piston 3 make up the turning pair. But piston 3 and cylinder 4 make up sliding kinematic pair, because it permits only reciprocal motion of the piston relative to the fixed link.

The character of links relative motion is determined by the shape of links elements that contact each other. Aggregates of surfaces, lines or points belonging to joined links during their relative motions are called elements of a kinematic pair.

1.2. Kinematic pairs classification

Kinematic pairs may be classified by the following features:

- 1) by the number of independent possible motions of one link relative to another (Dobrovolsky's classification);
- 2) by the number of connections that are imposed on relative motions of links by a kinematic pair (Artobolevsky's classification);
- 3) by the nature of contact of links (Relo's classification).

According to Dobrovolsky's classification kinematic pairs can be classified into kinds. In order to determine the kind of a kinematic pair it is necessary to choose two links that make up this pair. Assuming that one of links is a fixed one we will determine how many degrees of freedom a movable link has relative to the other, i.e. how many independent motions one link can perform relative to another.

As it is known from theoretical mechanics perfectly rigid body has six degrees of freedom in the space, i.e. can perform six independent motions: three rotatory motions around X, Y, Z axes and three translational motions along the same axes (Fig.1.2). If one link forms a kinematic pair with the other link that is firmly connected with the coordinate system then the first one cannot already make six motions relative to latter. Depending on the nature of joining the movable link can perform one, two, three, four or five motions relative to another link forming correspondingly one movable (the 1st kind), two movable (the 2nd kind), three movable (the 3rd kind), four movable (the 4th kind) or five movable (the 5th kind) kinematic pairs.

If one link of a kinematic pair has one degree of freedom relative to the other we deal with the 1st kind kinematic pair. Kinematic pairs of the 1st kind may be turning or sliding. Turning kinematic pair is a pair where one link relative to the other can perform rotatory motion only (Fig.1.3, a). In sliding kinematic pair one link relative to the other makes the translational motion only (Fig.1.3, b).

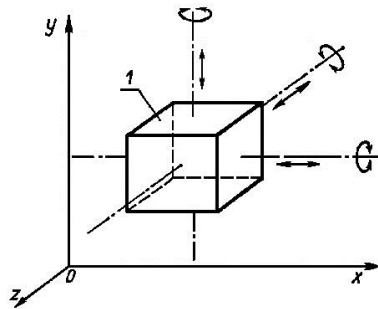

Fig.1.2. Possible motions of a free link in space

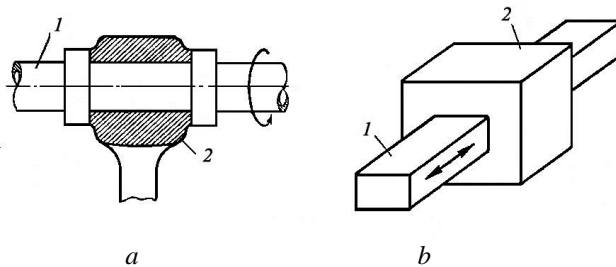

Fig.1.3. Kinematic pairs of the 1st kind: *a* - a turning pair;
b - a sliding pair

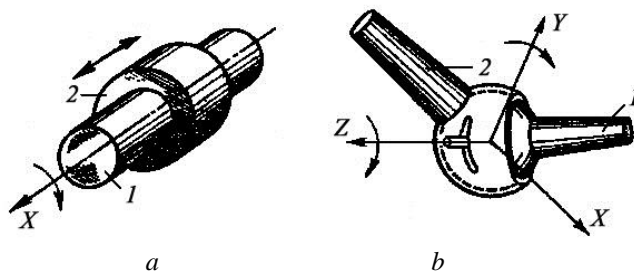

Fig.1.4. Kinematic pairs of the 2nd kind: *a* - a cylindrical pair;
b - a spherical pair with a pin

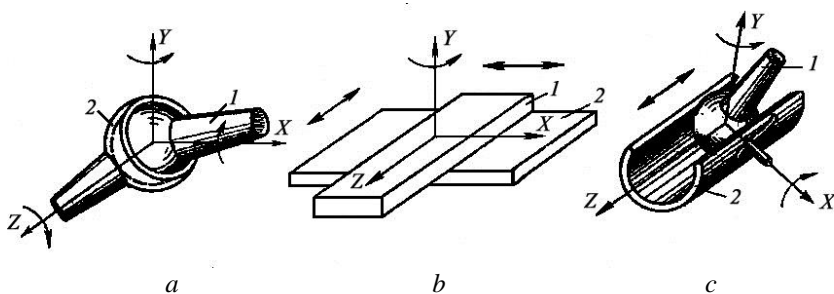

Fig.1.5. Kinematic pairs of the 3rd kind:
a - a spherical pair; *b* - a plane pair;
c - a kinematic pair "a sphere with a pin - a cylinder"

Kinematic pair of the 2nd kind contains a link that has two degrees of freedom relative to another one. Fig.1.4 shows the example of such kinematic pair where link 1 can perform rotatory motion around axis X and translational motion along the same axis.

In kinematic pair of the 3rd kind one link has three degrees of freedom with respect to another. Examples of such kinematic pairs are represented in Fig.1.4. Possible motions of one link relative to the other are shown by arrows.

There are kinematic pairs “a cylinder – a plane” and “a sphere – a cylinder” in Fig. 1.6. They are the 4th kind kinematic pairs, as link 1 has four free degrees relative to link 2. In the pair “cylinder – plane” cylinder 1 can rotate relative to plane 2 around Y and Z axes and moves forward along X and Z axes. In the pair “the sphere – the cylinder” sphere 1 can make three rotatory motions around X, Y, Z axes and one translational motion along Z axis.

The examples of the 5th kind kinematic pairs are a sphere or a cone on a plane (Fig.1.7). It is explained by the fact that the sphere or the cone (link 1) can make 5 independent motions relative to the plane (link 2): three rotatory motions around axes X, Y, Z and two translational motions along X and Z axes.

It is necessary to note, that possible motions of one link with respect to another can be either independent one from another or joined with each other by any additional geometrical conditions. For example, there is a screw pair in Fig.1.8. Rotatory motion of a screw (link 1) relative to a nut (link 2) brings to translation of this link along axis X by a certain distance. But the movement of link 1 depends on its turning angle. As a link number of freedom degrees is determined by the number of possible independent motions the screw pair is considered as the 1st kind kinematic pair because it is only one parameter, that determines the screw position in the nut (link turning angle).

According to Artobolevsky's classification kinematic pairs can be classified by classes. Class of a kinematic pair is determined by the number of connections imposed on a link's relative motions by a kinematic pair. There exist 5 classes. In order to find a kinematic pair's class it is necessary to count how many motions one link cannot perform relative to another.

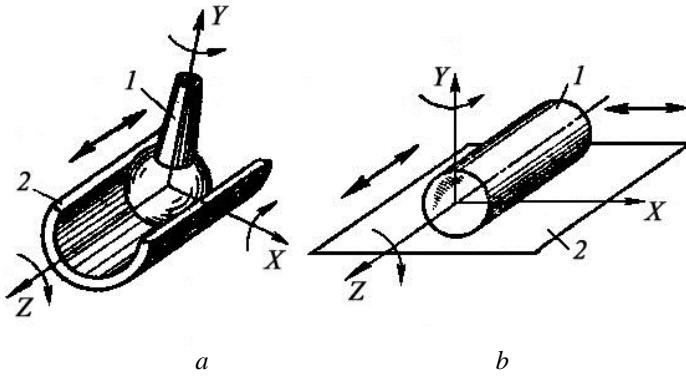

Fig.1.6. Kinematic pairs of the 4th kind:
a – a kinematic pair “a sphere – a cylinder”;
b – a kinematic pair “a cylinder – a plane”

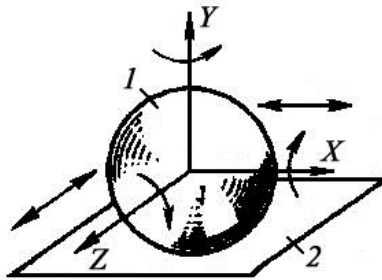

Fig.1.7. Kinematic pairs of the 5th kind (a sphere – a plane)

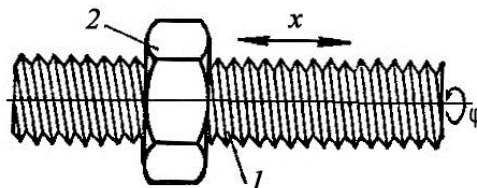

Fig.1.8. A screw kinematic pair of the 1st kind

Taking into account the definitions of a kinematic pair's kind and class we can make the conclusion that the 1st kind kinematic pair is simultaneously the pair of the 5th class; the 2nd kind kinematic pair is the pair of the 4th class and so on.

According to the nature of link's contact we will distinguish between higher and lower kinematic pairs (Reulo's classification). Lower kinematic pair is a pair whose links contact each other along the surface (Fig.1.3, 1.4, 1.5, *a* and *b*). Higher kinematic pair is a pair whose links contact along a line or at a point (Fig. 1.5, *c*, 1.6, 1.7).

Mentioned above kinematic pairs can be formed by links of space mechanisms. Space mechanism is a mechanism whose links can move in different non-parallel planes.

In theory of mechanisms and machines plane mechanisms are mostly considered. Plane mechanism is a mechanism whose links move parallel to one immovable plane. Links of plane mechanisms can form only the 1st and the 2nd kind kinematic pairs. It is explained by the fact that a free rigid body has only three degrees of freedom on the plane: it can perform two translational motions along X and Z axes and one rotatory motion around Y axis. If a body is a part of a kinematic pair, it loses one or two freedom degrees. Consequently, a kinematic pair of a plane mechanism may be one-movable or two-movable.

The 1st kind kinematic pairs (turning or sliding) of a plane mechanism are always lower. The 2nd kind plane kinematic pairs are higher, where possible motions of one link relative to another are translational and rotatory motions.

1.3. Diagrammatic representations of a plane mechanism kinematic pairs and links

During structural, kinematic and dynamic analysis mechanisms are usually represented by their diagrams. A mechanism diagram is graphical representation of a mechanism with usage of diagrammatic representations of links and kinematic pairs and ignoring a scale.

As it was mentioned above plane mechanisms may contain the 1st kind (turning or sliding) and the 2nd kind kinematic pairs.

Turning kinematic pair is shown as a hinge, which connects two links (Fig.1.9, *a*). Centre of a turning pair is marked by capital letter of

Roman alphabet A, B, C, etc. Links are denoted by Arabic numerals 1, 2, 3, etc.

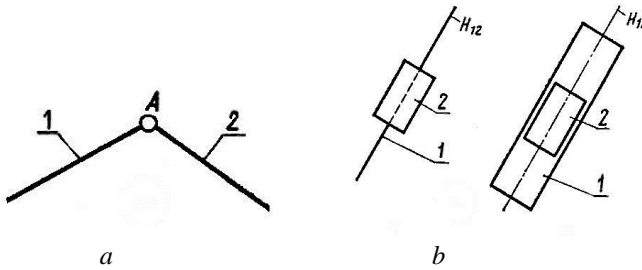

Fig.1.9. Diagrammatic representations of the 1st kind kinematic pairs:
a – turning pair; *b* – sliding pairs

Representation of a sliding kinematic pair is shown in Fig. 1.9, *b*. The guide of a sliding pair is marked by letter H with double subscript in accordance with links numbers that form a kinematic pair.

The 2nd kind plane kinematic pair is represented in Fig.1.10. Fig.1.10, *a* corresponds to a case when links contact each other by all their points (for example, a cam and a roller in a cam mechanism). If links contact occurs at certain portions of profiles (e.g. teeth of toothed wheels) then representation drawn in Fig.1.10, *b* is used.

Diagrammatic representations of a plane mechanism links are shown in Fig.1.11. Link that is a part of two or three kinematic pairs is represented by either a straight line or a hatched triangle irrespective of its constructive shape. Possible representations of a fixed link are given in Fig.1.12.

Depending on the link motion and its shape we will distinguish between the following types of mechanism links: a crank, a rocker,

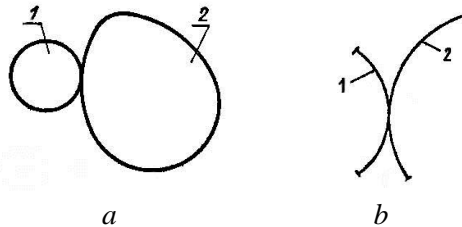

Fig.1.10. Diagrammatic representations of the 2nd kind kinematic pairs:
a – two links contact each other by all points; *b* – the contact of links occurs at some portion

a connecting rod (con-rod), a slider, a slotted link, a cam, a toothed

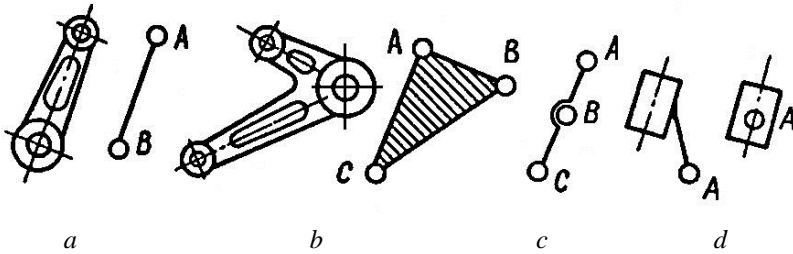

Fig.1.11. Diagrammatic representations of a link: *a* – a link is a part of two turning kinematic pairs; *b* - a link is part of three turning kinematic pairs; *c* – a link is part of three turning pairs centres of which are along one line; *d* – a link is part of a turning and a sliding kinematic pairs

wheel. A crank is a link of a leverage joined with a fixed link that makes complete revolution about immovable axis. A rocker arm is a leverage link joined with a fixed link that performs oscillatory motion about immovable axis of rotation (makes non-full revolution). A con-rod is a leverage link joined with movable links only that makes plane-parallel motion. A slider is a link of a leverage that performs translational motion relative to another link. A slotted link is a movable link of a leverage that is a guide for a slider. It may perform either rotatory or oscillatory motion. A cam is a link with curvilinear profile. A toothed wheel is a link with closed system of teeth that provides uninterrupted motion of a mating wheel per its complete revolution.

Representations of mentioned above links are given in table1.

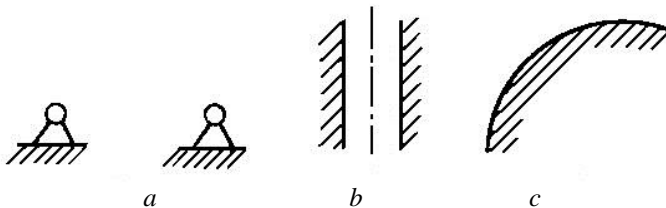

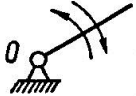







Fig.1.12. Diagrammatic representations of a fixed link: *a* – included into the structure of two turning pairs; *b* – included into the structure of one sliding pair; *c* – included into the structure of one pair of the 2nd kind

Table 1

Main types of mechanism links

Link	Diagrammatic representation	Nature of the motion	Features
Crank		Rotatory	Complete revolution
Rocker arm		Oscillatory	Non-full revolution
Con-rod		Plane-parallel	Cannot form a kinematic pair with a fixed link
Slider		Translational	Reciprocal motion
Slotted link		Rotatory, oscillatory	A guide for a slider
Cam		Rotatory	Cam profile determines the motion of a driven link
Cam		Translational	
Toothed wheel		Rotatory	Toothed contour

1.4. Kinematic chains

A kinematic chain is a system of links that form kinematic pairs. Kinematic chains are divided into simple and compound, closed and unclosed.

A simple kinematic chain is a kinematic chain in which every link is a part of not more than two kinematic pairs (Fig.1.13, *a, c*).

A compound kinematic chain is a kinematic chain with a link that is a part of three or more kinematic pairs (Fig.1.13, *b, d*).

A kinematic chain is called unclosed if it includes a link that is a part of one kinematic pair (Fig. 1.13, *a, b*).

If every link of a kinematic chain is a part of not less than two kinematic pairs it is called closed kinematic chain (Fig. 1.13, *c, d*).

In practice we may meet both unclosed and closed kinematic chains. The examples of unclosed chains are beam scales, manipulator mechanisms. A manipulator is a technical device that is used for reproduction of a man hand functions (Fig.1.14).

Kinematic chains are also divided into plane and space chains. Kinematic chains whose links move in parallel planes are called plane chains. Chains in which points of links move either along space curves, or along plane curves which lie in nonparallel planes are called space chains.

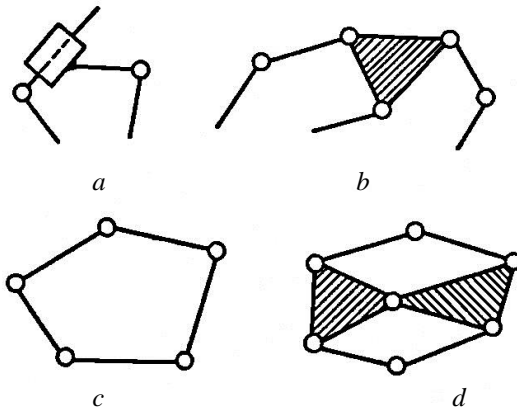

Fig.1.13. Kinematic chains: *a* – simple and unclosed; *b* - compound and unclosed; *c* – simple and closed; *d* - compound and closed

In mechanical engineering plane closed kinematic chains have found the most wide application.

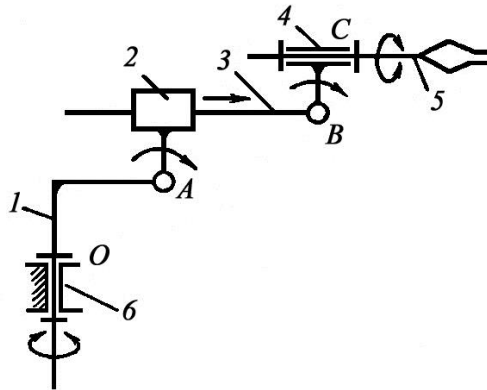

Fig. 1.14. Diagram of the manipulator mechanism

If a closed kinematic chain contains one immovable link and all links make certain motions when motion of one or some links is predetermined we may consider this chain as a mechanism.

1.5. Degrees of freedom of a mechanism

Degree of freedom of a mechanism is the number of independent forced motions that it is necessary to give for a mechanism links to provide certain relative motions of all other links.

Let us deduce the formula for determination of a plane mechanism number of degrees of freedom.

Let a plane mechanism consist of n links one of which is immovable. That is why the number of movable links is $n-1$. In the plane every free link has three degrees of freedom. If mechanism links were not joined with each other, then the total number of motions of all movable links should be $3 \cdot (n-1)$. But mechanism links are not free bodies. They are joined with each other by kinematic pairs. Every the 1st kind kinematic pair decreases the total number of motions by 2, and every the 2nd kind kinematic pair reduces the number of links motions by 1. If a mechanism has p_1 the 1st kind kinematic pairs and p_2 the 2nd kind pairs then the number of lost motions is $(2 \cdot p_1 - p_2)$. After subtracting lost motions of links from the total number of motions we obtain the formula

for determination of the number W of degrees of freedom for a plane mechanism.

$$W = 3 \cdot (n - 1) - 2 \cdot p_1 - p_2. \quad (1.1)$$

Formula (1.1) was developed in 1870 by Russian scientist P. Chebyshev (1821-1894) and is called Chebyshev's formula.

In the same way we may deduce the formula for finding the number of freedom degrees of a space mechanism. It has the following form:

$$(1.2) \quad W = 6 \cdot (n - 1) - 5 \cdot p_1 - 4 \cdot p_2 - 3 \cdot p_3 - 2 \cdot p_4 - p_5,$$

where p_1, p_2, p_3, p_4, p_5 are correspondingly the number of the 1st, 2nd, 3rd, 4th and 5th kind kinematic pairs. Equality (1.2) is known as Malyshev's formula.

In practice the number of freedom degrees of a mechanism determines the number of initial links. An initial link is a link that receives motion to transform it into necessary motions of a mechanism links. At mechanism diagrams initial links are marked by circular or straight arrows.

For the four-bar mechanism (Fig.1.15, *a*) the number of freedom degrees is

$$W = 3 \cdot (n - 1) - 2 \cdot p_1 - p_2 = 3 \cdot (4 - 1) - 2 \cdot 4 - 0 = 1.$$

It means that the mechanism has one initial link and it is enough to give motion for one link to provide certain motions of all other links. Thus, if link 1 receives rotatory motion then links 2 and 3 will also have

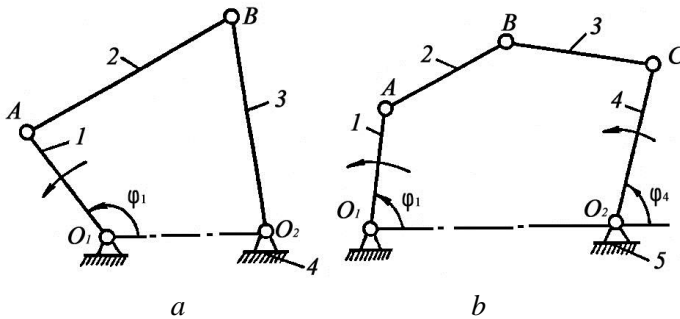

Fig.1.15. Determination of the degree of freedom of mechanisms:

a - a four-link mechanism ($W=1$); b - a five-link mechanism ($W=2$)
 certain motions. Position of link 1 may be given by turning angle φ_1 . This angular coordinate determines positions of the other links (2 and 3) too. That is why it is called a generalized coordinate.

The number of the mechanism degrees of freedom shown in Fig. 1.15, b is

$$W=3 \cdot (n-1) - 2 \cdot p_1 - p_2 = 3 \cdot (5-1) - 2 \cdot 5 - 0 = 2.$$

According to obtained result this mechanism has two initial links and position of all its links is determined by two generalised coordinate. It may be link 1 turning angle φ_1 and link 4 turning angle φ_4 .

Sometimes plane mechanisms may contain links that introduce either extra degrees of freedom or extra connections. These links are called passive links. For example, the cam mechanism shown in Fig.1.16 has four links such as cam 1, roller 2, follower 3 and fixed link 4. Links 1 and 4, 2 and 3 form turning kinematic pairs, links 3 and 4 make up the sliding kinematic pair and links 1 and 2 form the 2nd kind kinematic pair. The number of freedom degrees is

$$W=3 \cdot (n-1) - 2 \cdot p_1 - p_2 = 3 \cdot (4-1) - 2 \cdot 3 - 1 = 2.$$

But the position of the driven link, follower 3, depends on the position of the driving one, cam 1, only. It is explained by the fact that roller 2 has round shape and its centre of rotation coincides with the geometrical centre. That is why the roller can freely rotate around its axis

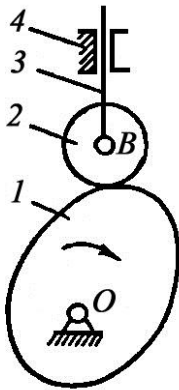

and does not influence the character of motion of the whole mechanism. Rotation of the roller is extra degree of freedom and the roller is the passive link. The roller is introduced into the mechanism construction to reduce friction forces and links wear.

Fig.1.17 shows the diagram of the parallelogram mechanism in which $\overline{OA} = \overline{BC}$ and $\overline{AB} = \overline{OC}$. The mechanism has one degree of freedom ($n=4, p_1=4, p_2=0, W=1$). In the parallelogram mechanism both cranks (links 1 and 3) rotate with identical

Fig.1.16. Cam mechanism angular velocity and in one direction. Con-rod 2 with the extra degree of freedom makes translational motion. When the mechanism comes to the extreme position (Fig.1.17,*b*) all links will be along one straight line. In this case

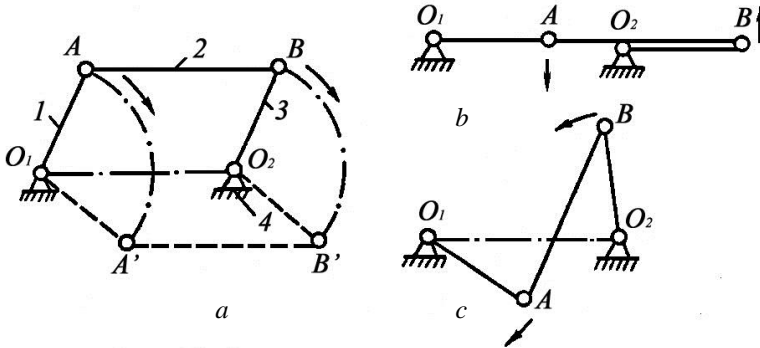

Fig.1.17. Diagram of the parallelogram mechanism: *a* – parallelogram; *b* - the extreme position of the mechanism; *c* – anti-parallelogram

the mechanism motion becomes indeterminate. The mechanism may either move as the parallelogram or point B may change direction of its motion (Fig.1.17,*c*) and the mechanism is transformed into an anti-parallelogram. In order to provide definiteness of the mechanism motion we will use a double-parallelogram mechanism (Fig.1.18) in which $\overline{DF} = \overline{AB}$. As in the previous case this mechanism will have one degree of freedom too although in accordance with (1.1)

$$W = 3 \cdot (n - 1) - 2 \cdot p_1 - p_2 = 3 \cdot (5 - 1) - 2 \cdot 6 - 0 = 0.$$

This result is explained by the fact that additional link 4 is the passive one. Making up kinematic pairs of the 1st kind with links 1 and 3 it introduces one extra (passive) connection ($q=1$) that is ignored in formula (1.1). Taking into account passive connections in a mechanism formula (1.1) will have the following form

$$W = 3 \cdot (n - 1) - 2 \cdot p_1 - p_2 + q.$$

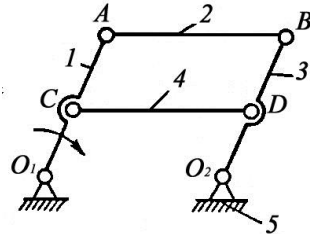

In our case we obtain

Fig.1.18. Double-parallelogram mechanism

$$W=3 \cdot (5 - 1) - 2 \cdot 6 + 1 = 1$$

that corresponds to reality.

Some mechanisms may have two and more passive links. They are used to ensure links determinate motion, to rise a system rigidity, to decrease influence of deformations on a mechanism motion, to reduce friction forces, etc.

1.6. Structure of plane mechanisms

Structural analysis and synthesis of mechanisms are based on the principle developed by professor of the St. Petersburg Polytechnic Institute L.V. Assur (1878-1920). According to this principle every plane mechanism with the 1st kind kinematic pairs can be divided into separate simple parts (groups of links) each of which form a kinematic chain.

The simplest kinematic chain whose number of freedom degrees is equal to the number of freedom degrees of the whole mechanism is called a group of initial links. Other kinematic chains whose number of degrees of freedom is equal to zero are called groups with zero degree of freedom or Assur's groups. Thus, every mechanism consists of one group of initial links and one or some Assur's groups. These groups determine mechanism structure. That is why they are called structural groups.

A group of initial links consists of a fixed link and one or several movable links named as initial. The number of initial links depends on the number of freedom degrees of the whole mechanism. If $W=1$ the group of initial links consists of a fixed link and one initial link forming

together with the fixed one the 1st kind kinematic pair (turning or sliding). In Fig.1.19 two types of the group of initial links are represented with $W = 1$. If the number of the degrees of freedom of a mechanism $W = 2$ the group of initial links includes a fixed link and two initial links that form kinematic pairs with the fixed link (Fig.1.20,a)

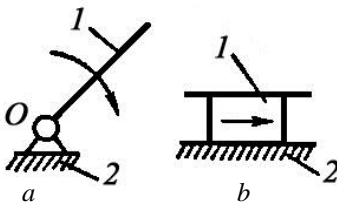

Fig.1.19. Groups of initial links:

a – link 1 forms a turning pair with the fixed link; b – link 1 forms a sliding pair with the fixed link

Assur's group is a kinematic chain after attaching of which to a fixed link by its free elements has zero degree of freedom. Assur's group cannot be divided into simpler parts and consists of movable links only that form the 1st kind kinematic pairs.

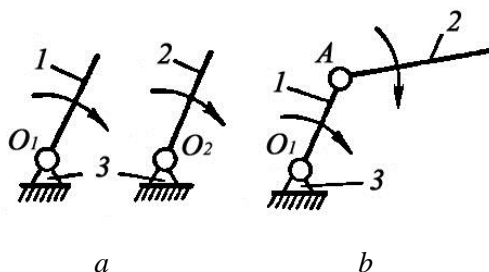

Fig.1.20. Two variants of the group of initial links: a – initial links form kinematic pairs with the fixed link; b – initial links are joined with each other

Let n' be the number of Assur's group links, p_1' be the number of the 1st kind kinematic pairs and W' be the number of degrees of freedom of Assur's group. Then according to Assur's group definition we may write

$$W' = 3 \cdot n' - 2 \cdot p_1' = 0. \quad (1.3)$$

Equation (1.3) will be satisfied if

$$n' = 2 \cdot k, \quad p_1' = 3 \cdot k,$$

where k is any integer numeral ($k = 1, 2, 3$, etc.)

If $k = 1$ we obtain an elementary Assur's group that consists of two links and three the 1st kind kinematic pairs. This group has five types depending on the number of turning and sliding kinematic pairs and their disposition (Fig.1.21). A kinematic pair that connects links of Assur's group with each other is called an inertial kinematic pair. Two other kinematic pairs by means of which this Assur's group is joined with adjacent mechanism links are called external kinematic pairs. A link of a group that is a part of both internal and external kinematic pairs is called an arm. The elementary Assur's group has two arms. That is why this

group is called as two-arm group or dyad. Every type of the dyad (Fig.1.21) is designated as dyad #1, dyad #2, etc.

With $k=2$ we have Assur's group that consists of four links and six kinematic pairs. In Fig.1.22 two variants of Assur's group are given with

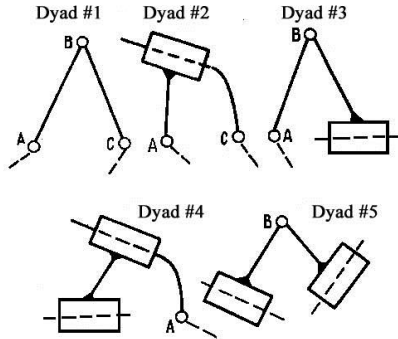

$k=2$. One of them (Fig.1.22, a) is called a three-arm group. A characteristic feature of the second variant of the group (Fig.1.22, b) is Fig.1.21. Types of the two-arm group - dyads

the presence of the closed contour. If one or several turning pairs are replaced by sliding ones, it will be possible to receive many various types of Assur's group with $k=2$. A three-arm Assur's group will have 20 types.

With $k=3$ Assur's group consists of six links and nine kinematic pairs and exists in ten variants having only turning kinematic pairs. One of them is shown in Fig.1.22, c

It is necessary to remember that complicated Assur's group cannot be divided into simpler structural groups.

Most modern mechanisms used in mechanical engineering usually have two-arm Assur's groups.

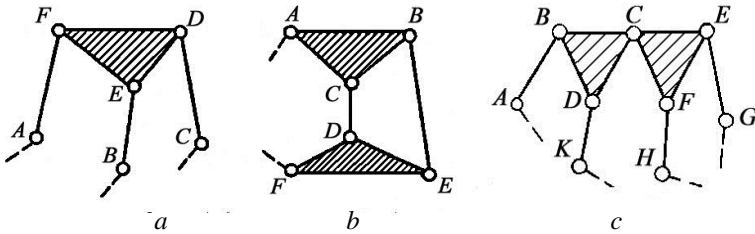

Fig.1.22. Compound Assur's groups: *a* – the 2nd class three –arm Assur's group; *b* – the 2nd class Assur's group with the closed contour; *c* - the 3rd class Assur's group

Assur's groups are classified into classes and orders.

Classification by classes was proposed by G.Baranov (1899-1968).

Class of Assur's group is determined by the number of k . With $k=1$ we deal with Assur's group of the 1st class; with $k=2$ Assur's group is of the 2nd class.

In order to determine an order of Assur's group (classification by I. Artobolevsky) it is necessary to count the number of external kinematic pairs or the number of arms.

According to mentioned above classification all dyads are Assur's groups of the 1st class and the 2nd order. The group of links shown in Fig.1.22,*a* is Assur's group of the 2nd class and the 3rd order. Fig 1.22,*b* shows the 2nd class and the 2nd order Assur's group.

1.7. Determination of the structure of plane mechanisms with the 1st kind kinematic pairs

To determine the structure of a mechanism means to determine what groups of links the considered mechanism consists of and how these groups of links are connected with each other.

Division of a mechanism into groups of links is made by successive separation of Assur's groups, which are the most remote from the initial link. The simpler mechanism remaining after each separation of Assur's group should have the same number of freedom degrees as the initial mechanism.

It is necessary to remember that during structural analysis every link and every kinematic pair should be taken into account only one time.

The representation of the mechanism structure is recommended to make by enumerating all groups of links in the order of their separation.

Let us consider as an example of structural analysis the swinging mechanism of the aircraft radar station aerial (Fig.1.23). For this mechanism $n = 8$, $p_1 = 10$, $p_2 = 0$. Then the number of degrees of freedom is

$$W = 3 \cdot (n - 1) - 2 \cdot p_1 - p_2 = 3 \cdot (8 - 1) - 2 \cdot 10 - 0 = 1.$$

Thus, the mechanism has one initial link. We will choose link 1 as the initial link and mark it by arrow.

The most remote Assur's group relative to the initial link consists of links 6 and 7 and three turning kinematic pairs F, K and H. These links form dyad #1 (Fig.1.23, b). The mechanism part remaining after separation of links 6 and 7 has the same degree of freedom as the initial mechanism ($W=1$). The following Assur's group consists of links 4 and 5 and three kinematic pairs such as turning pair D and two sliding pairs. Links 4 and 5 form dyad #4 (Fig. 1.23, c). In the same we separate from the mechanism links 2 and 3 with turning kinematic pairs A, B and C that form dyad #1 (Fig. 1.23, d). At last links 1 and 8 with turning kinematic pair form the group of initial links (Fig. 1.23, e).

Thus, the representation of the mechanism structure has the following form:

- 1) links 6 and 7 – dyad #1;
- 2) links 4 and 5 – dyad #4;
- 3) links 2 and 3 – dyad #1;
- 4) links 1 and 8 – group of initial links.

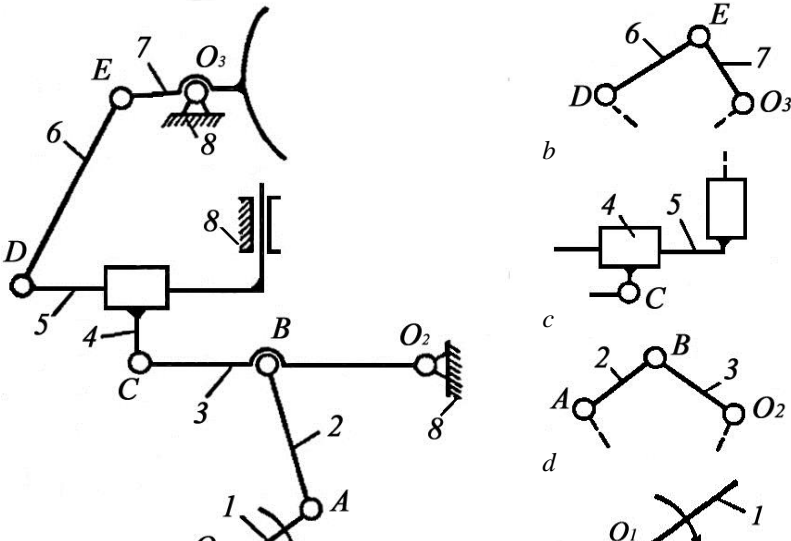

Fig.1.23. Determination of the structure of the swinging mechanism of the aircraft radar station aerial: *a* – mechanism diagram; *b* – dyad # 1; *c* – dyad # 4; *d* – dyad # 1; *e* – group of initial links

1.8. Synthesis of four links mechanisms

In up-to-date engineering one of the most widespread plane mechanisms with lower kinematic pairs are four links mechanisms. They are formed as a result of attaching Assur's group of the 1st class (dyad) to a group of initial links.

If dyad #1 is joined with the group of initial links ($W=1$) we obtain a four-bar mechanism (Fig.1.24, *a*). In engineering we come across various types of four-bar mechanisms, depending on relative length of the links. They may be with one crank and one rocker arm, or with two cranks, or with two rocker arms.

In the crank and rocker arm mechanism the crank (link joined with a fixed link and performing the full revolution) will be the shortest link in the case when the sum of lengths of the shortest and the longest links is less than the sum of two other lengths.

The crank and rocker arm mechanism is used in metal cutting machine tools, presses, forging machines, textile machines, printing machines and others.

If links 1 and 3 as well as links 2 and 4 have identical length and form parallelogram (Fig.1.17) we obtain the mechanism with two cranks

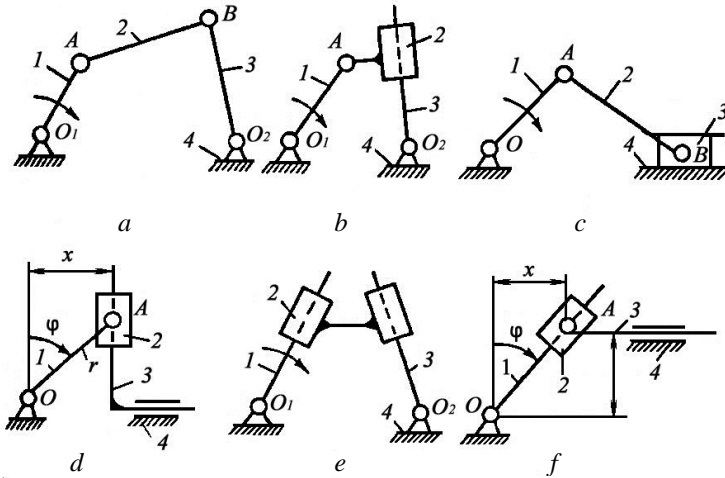

Fig.1.24. Four-link mechanism: *a* – four-bar mechanism; *b* – slotted link mechanism; *c* – crank and slider mechanism; *d* – double slider mechanism; *e* – double slotted link mechanism; *f*– slotted link and slider mechanism because links 1 and 3 have possibility to make the complete revolution. Two cranks parallelogram mechanisms may be used in locomotives for transmitting rotatory motion to driven wheels or in devices for drawing.

If the shortest link is con-rod 2 we obtain the mechanism with two rocker arms that may be employed in portal cranes.

When a mechanism consists of dyad #2 and the group of initial links we deal with the slotted link mechanism (Fig.1.24, *b*) in which link 3 is the slotted link. Depending on the length of crank OA and centre distance OC the slotted link may perform either oscillatory motion (if $OA < OC$) or rotatory motion (if $OA > OC$). The slotted link mechanism is used in metal cutting machine tools, hydraulic and pneumatic drives, at airplanes for landing gear retraction and extension and so on.

If dyad #3 is connected with the group of initial links we obtain the widespread crank and slider mechanism (Fig.1.24, *c*) that is used in internal combustion engines, piston compressors and pumps, presses, etc.

After joining dyad #4 to the group of initial links we may obtain either the double slotted link mechanism (Fig.1.24, *d*) or the double slider

mechanism also called as the sine mechanism (Fig.1.24, *e*). In the double slotted link mechanism the angular velocities of links 1 and 3 are identical. That is why this mechanism may transmit motion between two eccentrically located shafts and is used at double slider (Oldham) couplings.

In the sine mechanism rotatory motion of crank 4 is transformed into reciprocal motion of slider 3. In this case the displacement of the slider is proportional to sine of the crank turning angle ($X=r \cdot \sin \varphi$).

The slotted link and slider mechanism formed as a result of joining dyad #5 with the group of initial links is shown in Fig 1.24, *f*. In this mechanism the displacement of slider 3 is proportional to tangent of the turning angle of slotted link 1 ($X=l \cdot \tan \varphi$). That is why it is also called as the tangent mechanism. This mechanism is used quite seldom because link 1 can turn at angle less than 180 °.

1.9. Replacement of higher kinematic pairs with lower in plane mechanisms

Plane mechanisms may have both lower and higher kinematic pairs. In plane mechanisms higher pairs are the 2nd kind kinematic pairs. We may determine structure of a mechanism with the 2nd kind kinematic pairs only after replacement of higher pairs with lower. In this case the condition of structural equivalence must be satisfied. It means that the replaced mechanism has to have the same degree of freedom as the initial mechanism.

Fig.1.25, *a* shows the three-link mechanism with two turning kinematic pairs O and C and one the 2nd kind kinematic pair that is formed by links 1 and 2. Profiles of these links are circles of radii AK and BK. During the mechanism motion point K of profiles contact changes its position both in the immovable plane and on links profiles. But in this case the distance between points A and B is not changed. That is why this mechanism is equivalent to the four-bar mechanism (Fig.1.25, *b*) in which lengths of links OA, AB, BC are equal to the lengths of corresponding segments in Fig.1.25, *a*. Replaced mechanism OABC is equivalent to the initial one from the viewpoint of laws of motion of links 1 and 2 because the angular velocities of these links are identical at both mechanisms ($\omega_1' = \omega_1, \omega_2' = \omega_2$).

If profiles of links forming a higher kinematic pair are curves of variable curvature then every position of a mechanism will correspond to one “momentary” replaced mechanism in which points A and B will be the centres of curvature and segments AK and BK will be corresponding radii of curvature of curvilinear profiles.

Thus, the equivalent of the 2nd kind kinematic pair formed by links with curvilinear profiles is one additional link that is a part of two turning kinematic pairs of the 1st kind placed at the centres of curvature of curvilinear profiles.

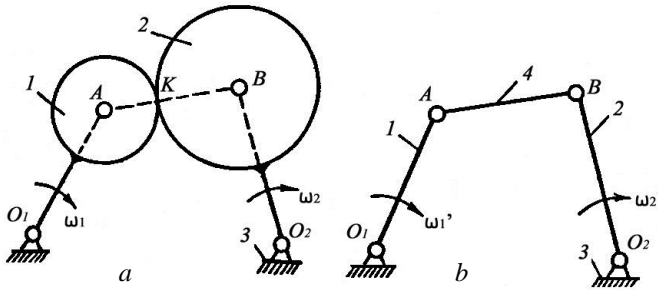
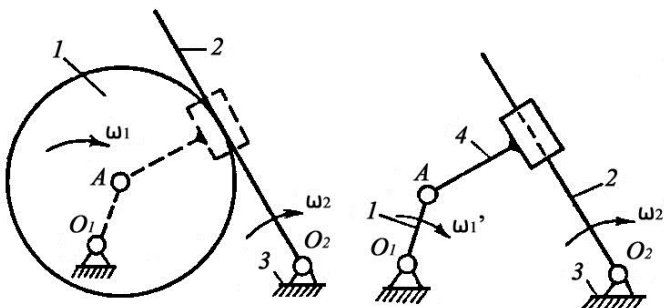

Fig.1.25. Three-link mechanism with the higher kinematic pair formed by curvilinear profiles: *a* – mechanism diagram; *b* – replaced mechanism

If in a plane mechanism one of two links that form the 2nd kind kinematic pair has curvilinear profile and the other has rectilinear profile (Fig.1.26) then the centre of curvature of the other link with rectilinear profile is infinitely far. That is why at the equivalent mechanism additional link 4 forms with link 2 the sliding (not turning) kinematic pair that is located at any place of rectilinear profile (Fig.1.26, *b*).

Thus, the equivalent of the higher kinematic pair, formed by links with curvilinear and rectilinear profiles, is one additional link with turning and sliding kinematic pairs. A turning pair is located at the centre of curvature of curvilinear profile and a sliding one is at any place of



rectilinear profile.

a

b

Fig.1.25. Three-link mechanism with the higher kinematic pair formed by links with curvilinear and rectilinear profiles : *a* – mechanism diagram; *b* – replaced mechanism