

MINISTRY OF EDUCATION AND SCIENCE OF UKRAINE  
NATIONAL AVIATION UNIVERSITY  
FACULTY OF ARCHITECTURE, CIVIL ENGINEERING AND DESIGN  
COMPUTER TECHNOLOGIES OF CONSTRUCTION DEPARTMENT

TO ADMIT TO GUARD  
Head of the Department

\_\_\_\_\_ O.I. Lapenko

“ \_\_\_\_\_ ” \_\_\_\_\_ 2020

# MASTER THESIS

## (EXPLANATORY NOTE)

**Topic:** *Optimization of prestressed roof structures' cross sections of industrial buildings*

**Performed by:** Student of group 205ma Galaka V.V. \_\_\_\_\_

(student, group, last name, first name, patronymic)

**Scientific adviser:** Ph. D, Candidate in Engineering Kostyra N.O.

(academic degree, academic rank, last name, first name, patronymic)

Adviser of the chapter «Labour protection»: \_\_\_\_\_ Kovalenko V.V.  
(signature) (Surname, initials)

Adviser of the chapter

«Environment protection»: \_\_\_\_\_ Radomskya M.M.  
(signature) (Surname, initials)

Design rule check: \_\_\_\_\_ Rodchenko O.V.  
(signature) (Surname, initials)

Kyiv 2020



МІНІСТЕРСТВО ОСВІТИ І НАУКИ УКРАЇНИ  
НАЦІОНАЛЬНИЙ АВІАЦІЙНИЙ УНІВЕРСИТЕТ  
ФАКУЛЬТЕТ АРХІТЕКТУРИ, БУДІВНИЦТВА ТА ДИЗАЙНУ  
КАФЕДРА КОМП'ЮТЕРНИХ ТЕХНОЛОГІЙ БУДІВНИЦТВА

ДОПУСТИТИ ДО ЗАХИСТУ

Завідувач випускової кафедри

\_\_\_\_\_ О.І. Лапенко

“ \_\_\_\_\_ ” \_\_\_\_\_ 2020 р.

## ДИПЛОМНА РОБОТА

(ПОЯСНЮВАЛЬНА ЗАПИСКА)

ВИПУСКНИКА ОСВІТНЬОГО СТУПЕНЯ МАГІСТРА

ОСВІТНЬО-ПРОФЕСІЙНА ПРОГРАМА «ПРОМИСЛОВЕ І ЦИВІЛЬНЕ БУДІВНИЦТВО»

**Тема:** : “ Оптимізація поперечних перерізів попередньо напружених конструкцій покриття промислових будівель”.

**Виконавець:** студент групи 205м Галака Вікторія Віталіївна

(студент, група, прізвище, ім'я, по батькові)

**Керівник:** : \_\_\_\_\_ к.т.н. доцент Костира Н.О.

(науковий ступінь, вчене звання, прізвище, ім'я, по батькові)

Консультант розділу «Охорона праці»: \_\_\_\_\_ Коваленко В.В

(підпис)

(ПІБ)

Консультант розділу

«Охорона навколишнього середовища»: \_\_\_\_\_ Родомська М.М.

(підпис)

(ПІБ)

Нормоконтролер:

(підпис)

\_\_\_\_\_ Родченко О.В.

(ПІБ)

Київ 2020



# CONTENT

|   |  |
|---|--|
| Introduction.....   |  |
| <b>1. Analytical review .....</b>   |  |
| <b>2. Scientific part .....</b>   |  |
| 2.1. Arrangement and design of trusses pre-stressed by tendons .....                                      |  |
| 2.2. Calculation of the trusses .....   |  |
| 2.3. Trusses with multi-stage pre-stressing .....   |  |
| 2.4. Experimental investigations of trusses .....   |  |
| 2.5. Conclusion .....   |  |
| <b>3. Architectural part .....</b>  |  |
| 3.1. Volume-planning decision .....   |  |
| <b>4. Structural part .....</b>   |  |
| 4.1. Characteristics of the industrial building .....   |  |
| 4.2. Calculation and design the open-web left column of the one-storeyed industrial buildings frame ..... |  |
| 4.2.1. Calculation of above crane part of the column .....  |  |
| 4.2.2. Calculation and design the undercrane part of column .....   |  |
| 4.2.3. Design and calculation the top and bottom column's part .....                                      |  |
| 4.2.4. Design and calculation the base of the column.....   |  |
| 4.2.5. Conclusions .....  |  |
| 4.3. Calculation of the truss prestressed by tendons .....  |  |
| <b>5. Bases and foundations .....</b>   |  |
| 5.1. Calculation of the pile foundation .....   |  |
| 5.1.1. Determination of the foundation depth .....  |  |
| 5.1.2. Determination bearing capacity of pile along the soil .....  |  |
| 5.2. Checking of weak underlying layer of sandy loam .....  |  |
| 5.3. Determination of foundation settlement by method of layering summation .....                         |  |
| <b>6. Occupational safety .....</b>   |  |
| 6.1. Analysis of harmful and dangerous production factors .....   |  |



6.2. Measures to reduce the impact of harmful and dangerous production factors .....

6.3. Occupational Safety Instruction .....

**7. Environment protection .....**

7.1. Impact of construction works on soil and geological environment .....

7.1.1. Impact on land, soils .....

7.1.2. Impact on landscape and geological environment .....

7.2. Description of the provided measures aimed at preventing, avoiding, reducing, removing significant negative effects on the country for people .....

7.2.1. Measures to minimize the impact on the geological environment .....

7.2.2. Protection and rational use of soils and land resources .....

**7.3. Conclusion .....**

**Conclusion .....**

Literature .....

Appendix 1 .....



## INTRODUCTION

The subject of my diploma project «Optimization the cross-sections of the pre-stressed roof structures of industrial buildings» is actual because tendency of erection of industrial buildings with working sites where is necessity of materials storage and repair of technological equipment.

Pre-stressing and regulation of forces are mean of improvement of building structures, decreasing of their cost, economy of materials.

**The purpose is** an analysis of the strained-deformed state of the trusses of the industrial sites of industrial buildings, taking into account the optimization of the section.

**The object of research** is stress strain state of one-storeyed industrial building load-bearing roof structures.

**The subject of research** is optimization the cross-sections of the pre-stressed roof structures of industrial buildings.

### **Research methods:**

- numerical methods (finite element method (ITU))
- numerical method, using the software program "LIRA-SAPR".



**CHAPTER 1**  
**ANALITICAL REVIEW**



## 1. Analytical review

Modern conditions of construction of buildings and structures, which are characterized by the introduction of new and efficient structures, are inextricably linked with the problems of developing methods of research and design of these structures. Such structures include combined reinforced concrete sprung systems. Historical experience in the application of combined reinforced concrete structures in the practice of construction has shown their effectiveness, which was to reduce the cost of concrete and steel compared to similar reinforced concrete or metal structures and, consequently, the total weight. Taking into account the above advantages, as well as rational spatial work and high technical and economic efficiency of steel sprung structures of the floor or roofing, combining them on the stiffening beam with reinforced concrete for joint work is a promising area of development of building structures.

In the combined reinforced concrete sprung pre-stressed structures, steel beam and sprung elements and a reinforced concrete slab work together. The use of such structures in construction requires more detailed research and improvement. The peculiarity of the proposed designs is that the upper reinforced concrete elements perceive the compressive and bending forces, and the suspension elements perceive the tensile or compressive forces. For effective operation of such structures it is necessary to determine their rational geometric characteristics, strength and deformability of the elements.

Solving the issue of developing research methods and designing combined reinforced concrete sprung pre-stressed structures under the condition of ensuring a high level of bearing capacity at low mass is an actual problem.

Pre-stressing of reinforced concrete structures in the form of sprung tendons makes it possible to significantly improve the parameters of strength and deformability of both individual elements and the structure as a whole. It allows designers to create structures that have better strength and durability, including in conjunction with a reinforced concrete slab.



In construction practice, pre-stressing in the form of sprung tendons is effectively used in the installation of reinforced concrete structures of floors and ceilings of buildings and structures span structures of bridges of various spans, as well as their reconstruction or reinforcement. The use of sprung ties has advantages that allow: by rational search to find the optimal physical and mechanical parameters of the structural elements, its topology, to reduce the height of the cross sections of the elements; to regulate the forces in the structural elements; to carry out strengthening under the influence of external loading; to control and regulate the pre-voltage; simplify construction and repair work without interruption of the technological process. However, combined reinforced concrete pre-stressed sprung structures (PSSS) are not widely used in construction due to the lack of a generalized method of their calculation and the lack of experimental studies.

The methods of calculation of combined pre-stressed reinforced concrete sprung structures lag far behind the methods of calculation of reinforced concrete, metal or reinforced concrete elements. In order to increase the efficiency and wider dissemination of PSSS, it is necessary to further improve the theory and methods of their calculation.

In the dissertation of Ivanyk Y.I. on the topic: "Strength and deformability of combined reinforced concrete pre-stressed structures" is proposed a new structural principle of combination of functions for reinforced concrete floors or coatings, in which the joint work of reinforced concrete slab and beams is carried out using a sprung system: pre-stressing pre-stressed in the initial stage of manufacture by means of puffs steel beams of rigidity of the metal combined sprung structure.

Inclusion of a reinforced concrete plate in joint work with metal beams of rigidity of the combined sprung design provides economy of steel in comparison with a similar design which has no inclusion in work with a reinforced concrete plate. Some pre-stressed reinforced concrete structures, in which high-strength reinforcement is used as the third structural material, may approach the cost of steel to reinforced concrete structures.

Special works [63], [64], are devoted to the review of structural solutions of reinforced concrete structures. The main aspects of the development of reinforced concrete





structures are considered in the scientific works of Z. Blikharsky [67], F.Ye. Klimenko [65], L.M. Kostikova [66], O.V. Semka, O.P. Voskobiynyk, L.I. Storozhenka, M.M. Streletsky, Y.M. Fabryka, E.R. Hilo, B.S. Popovych and others. In many works [66] reinforced concrete structures include structures with sheet external reinforcement, which can be combined with rod internal reinforcement.

The strong growth of industry in Western Europe in the nineteenth century created new challenges in the construction industry: increasing the span and dimensions of bridges, the number of storeys of buildings and structures, strength, fire resistance and durability. The first structural elements, which proposed the joint work of concrete and steel, were developed by English engineers Watt and Boulton (factory closure in Manchester, 1801), Fox (1829), William Ferburn (1845), French inventor Monnet 1867), American T. Giatt (1877). A powerful contribution to the study of the joint work of concrete and steel was made by the American researcher William E. Ward [24].

In Ukraine, the first reinforced concrete structures began to be used as floors in the late nineteenth century. In a significant number of buildings in the central part of Lviv and other cities of Western Ukraine, designed by Zakhariyevych's architectural studio and built by engineer M. Levitsky (for example, the building of the legal building of Ivan Franko National University), reinforced concrete was already used at that time.

In 1939, "Alpha" beams were patented in Switzerland, which were distinguished by welding to the upper belt of reinforcing spirals to combine reinforced concrete and steel. The first reinforced concrete structures with beams of the "Alpha" system were built in New York and Switzerland [25].

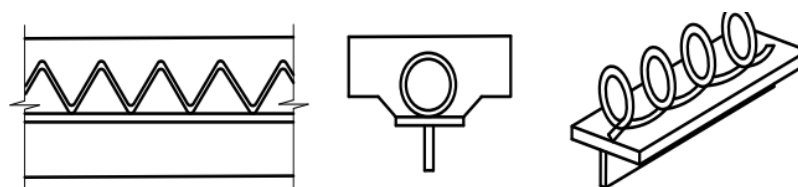

**Fig.1.1.** Combination of reinforced concrete and steel of the "Alpha" system [22], [23], [50].



E.I. Belenya , G.L. Vatulya, V.M. Vakhurkin, A.A. Voevodin, Y.V. Gaidarov, M.V. Gogol, Ye.O. Grinevich, M.P. Zabrodin, A.V. Mazurak, V.V. Mikhailov, V.O. Permyakov and others. Among foreign researchers it is necessary to note P. Aliawdin, S.Chen, T. Hyatt and others.

The use of combined metal structures of the sprung type in various fields of technology convincingly shows their advantages over other structural forms, in particular, reduced steel consumption, which is due to the rational contour of ties made of high-strength steels, effective profiles used as beams.

Pre-stressed beams have increased rigidity, which allows to significantly reducing their height and, accordingly, the volume of the building. Pre-stressing is one of the effective ways to reduce the deformability and material consumption of beams of rigidity of the sprung structure. Metal savings are 10 ... 20%, the cost is reduced by 5 ... 12% [40], [49], [57].

In the world practice of construction already in the twentieth century there were a number of examples of constructive application of pre-stress. Among the first publications on the study of pre-stressing can be called the scientific works of Vakhurkin VM, Gaidarova Yu.V., R. Buchwalter (USA), F. Dichinger (Germany) and others. Due to cost savings in metal and ease of manufacture, pre-stressed combined sprung structures are actively used by foreign engineers.

Belenya E.I. in the 60s of the last century in his works summarized the results of research methods of calculation and development of pre-stressed structures [4], [17], [18].

In the works of Streletsky M.M. noted that the economy of steel as a result of pre-stressing and regulation is provided in reinforced concrete span structures in three ways:

- favorable distribution of forces (bending moments, axial forces, transverse forces, torques) between sections and elements of statically indeterminate structures due to the artificial creation of a mutually balancing system in the structure of the forces opposite to the forces from external loads;



- favorable distribution of forces and stresses inside the cross-sections of reinforced concrete elements due to the artificial creation of mutually balancing within each cross-section of the diagrams of stresses, mainly compressing the reinforced concrete slab and unloading the steel part of the section;
- effective use of high-strength materials – high-strength reinforcement, which for its full use must be pre-stressed with compression of the main structures, or high-strength concrete, which for full operation must be pre-compressed with tensile steel.

The main purpose of pre-stressing is that the structure is pre-created stress-strain state, which is inverse in sign to what will take place during operation of the structure. Therefore, when the load is applied, the forces that were created in the process of pre-stressing are first overcome, and only then at the subsequent load (at 25 operations) there are inverse signs of force, in the process of growth of which comes one of the limit states of the structure.

Pre-stressing allows to apply concretes of the increased durability and accordingly to reduce own weight of designs.

Babich E.M. made a great contribution to the creation and development of prestressed reinforced concrete, Bambura A.M., Bogdanov O.M., Hitman E.M., Gnidets B.G., Grinevich Ye.O., Dorofeev V.S., Klimov Y.A., Pelmutter A.W., Pichugin S.V. and others.

By increasing the crack resistance and reducing deflections, the pre-stressing has almost no effect on the strength of reinforced concrete structures in normal sections, although to some extent increases the strength in inclined sections.

The method of calculation of pre-stressed reinforced concrete structures is included in the current regulations [16, 36, 38]. Since crimping does not affect the strength of



normal sections, the selection of working longitudinal reinforcement is the same method as the structures without pre-stress.

One of the simplest methods of pre-stressing metal beams is the introduction of tendons. A number of works are devoted to this problem, in particular, Yu.G. Ametova, V.V. Asanova, E.O. Hrynevych, M.Yu. Izbash, 28 Yu.O. Kushnir, V.F. Penza, O.L. Shagin and others. High-strength tendons are installed in areas where the highest stresses are applied. When the tension is tightened, a bending moment acts on the beam, which causes normal stresses in the cross-sections of the beam, opposite to the stresses from the external load. In this way, not only the unloading of the beam is achieved, but also the reduction of normal stresses in its sections. The beam has an extra connection (tendon) and is therefore statically indeterminate. One of the simplest ways to solve such a statically indeterminate structure is the force method, in which, when calculating the beam, the tightening force is taken as unknown. When calculating the deflections take into account the bending of the beam from the previous tension of the tendon.

## PARTICULARITIES OF BEAM BEHAVIOUR

Introduction of a tendon converts a beam to a statically indeterminate system. Under the service loads the bearing capacity of the beam increases, first, because the pre-stresses are cancelled initially, a fact which extends the elastic service range of the material, and, second, because a beam with a tendon behaves as a statically indeterminate system (trussed beam)[54], [55].

The tendon is located on the side of beam fibres in tension, and the tensile stresses in the tendon, balanced by compressive stresses in the beam, provide an additional moment of internal forces which partly counteracts the external bending moment [30].

The behaviour of the beam over the elastic range in the cross section of maximum bending moment may be subdivided into two stages (Fig. 1.1):

**Stage One**, or pre-stressing the beam. The pre-stressing force  $X$  creates stresses  $\sigma_{01} = X/F$  and  $\sigma_{02} = X_{cy}/I$  across the beam.



**Stage Two**, or behaviour of the beam under load until the stress in one of the outer fibres attains the yield point. At this stage the tendon is the site of an additional self-stressing force  $X_1$  which induces, across the beam, stresses  $\sigma_{01} = X_1 / F$  and  $\sigma_{02} = X_{1cy} / I$  of the opposite sign to stresses due to external load  $\sigma_p = M_y / I$ .

Stage I—from pre-stressing; Stage II—from an external load

If a beam is stressed over the elastic range only, the formulas for determining the beam strength are as follows:

(a) for a compressed (by a load) fibre

$$\sigma_{com} = -\frac{M}{W_1} - \frac{X + X_1}{F} + \frac{(X + X_1)c}{W_1} \leq R \quad (1.1)$$

(b) for a fibre in tension

$$\sigma_t = \frac{M}{W_2} - \frac{X + X_1}{F} + \frac{(X + X_1)c}{W_2} \leq R \quad (1.2)$$

$$\sigma_{td} = \frac{X + X_1}{F_{td}} \leq R_{td} \quad (1.3)$$

where  $X$  = pre-stressing force

$X_1$  = self-stressing force in the tendon

$M$  = bending moment due to external load

$W_1$  = moment of resistance of the beam for a compressed (due to action of load) fibre of the section

$W_2$  = moment of resistance of the beam for a tensioned fibre of the section

$F$  = cross-sectional area of the beam

$F_{td}$  = cross-sectional area of the tendon



$c$  = distance between the centre of tendon and the centre of gravity of the beam cross section

$R$  = design resistance of beam material

$R_{td}$  = design resistance of tendon material

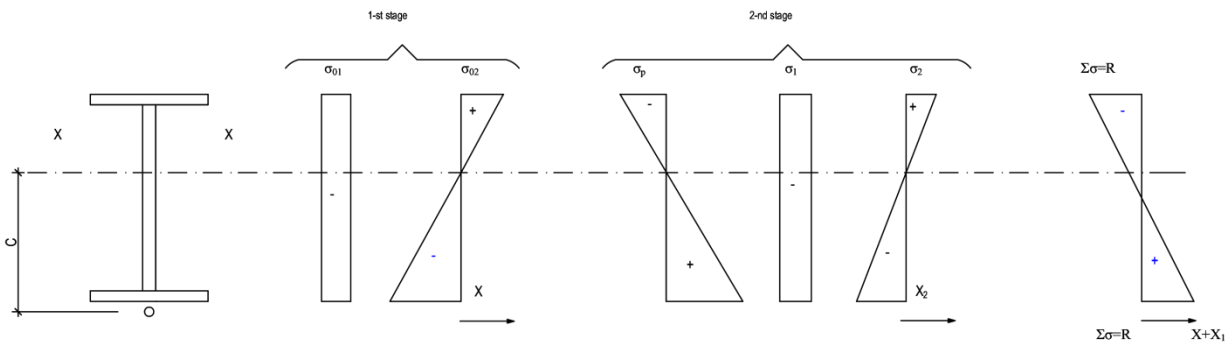

**Fig.1.1. Stresses in a beam in the elastic range**

**Stage 1- from prestressing; Stage 2 – from an external load**

In multi-span inseparable beams, given that there is also significant bending moments near the supports, tendons are installed not only in the spans, but also over the supports in accordance with the nature of the plot of bending moments.

Today we know the most common methods of controlling the pre-tensioning of reinforcement and ties with a dynamometer, manometer, elongation measurement, transverse extensions and others. The dynamometer is used in mechanical tensioning methods, including continuous reinforcement. The method is based on the readings of the deformation of the tie associated with the tensile strength of the valve. Tension force measurements are used for single and group tension of all types of reinforcement: rod, wire and rope.

Controlling the tension of the reinforcement to measure its elongation is one of the simplest methods. Elongation of the reinforcement in the process of its tension is measured using a special device. This method can be used in many ways of tensioning the



reinforcement, but most often it is used for mechanical tension of the reinforcement with jacks.

It is recommended to perform mechanical tensioning of fittings in two stages. First, the effort is transmitted, which is 45 - 50% of the design value. At such tension the correctness of an arrangement and fixing of rods and anchor devices is checked. Then the tension of the valve is brought to a force exceeding the design by 10%, the voltage is maintained for 3-10 minutes, after which the force in the valve is reduced to the design.

In the process of research, different authors have proposed different classifications of pre-stressing techniques and constructive forms [67, 68]. Despite the wide variety of structural forms of combined systems, today only a few methods of their pre-stressing are used. Having studied the previously mentioned features, the methods of pre-stressing in structures can be classified according to the following features:

1. In order to: create in the structural elements of the initial stresses that reduce the stress from operating loads; ensuring the efficiency of flexible elements of the system for compressive forces; reduction of structural movements from operating loads; increasing the endurance of structural elements; increasing the strength of the system when calculating the yield strength due to the effect of increasing the cross section; inclusion in work of additional elements at strengthening of existing designs under loading.

2. According to the method of pre-stressing: tightening of individual elements to create the initial stress: in individual rods and the structure as a whole; elastic deformations of structural elements.

3. By type of equipment that creates pre-stressing forces: with the use of stationary equipment (couplings, screw anchors, etc.); using reusable equipment (jacks, clamps, stationary stands, cargo, etc.); transformation of the scheme of work of a design or its elements in the course of assembly or installation for the purpose of creation of necessary initial pressure of the corresponding character (change of conditions of slinging, temporary loading); electrothermal method.



4. At the place of creation: completely at the factory; partly at the factory and partly at the assembly site; completely on the assembly site; partly on the assembly site, partly during installation in the design position; completely during installation in the design position.

5. By the number of stages: one-stage (single-stage); multistage.

One of the promising ways to develop systems with artificial force regulation is to combine in one constructive form different methods of pre-stressing, [68].

The work is one of the areas of research work of the National University "Lviv Polytechnic", which was conducted at the Faculty of Civil Engineering from 1950 to 1976. The beginning of research was the branch scientific and technical program of the USSR for 1986-1990 "To develop and implement progressive methods of construction support of reconstruction and technical re-equipment of industrial enterprises, reducing terms of input of capacities, cost of construction and assembly works due to the maximum use of constructions is especially relevant in this. During the independence of Ukraine, the work was performed in accordance with: "The main directions of social policy for 1997-2000", according to the Decree of the President of Ukraine of 18.10.1977, № 1166; Order of the State Construction Committee of Ukraine "A set of short and long-term measures aimed at increasing the production of competitive products, structural changes in the construction and housing sector, creating new jobs, increasing profitable government activities, ensuring timely payments to the budget and wages" from 28.12.1999, № 313; Order of the State Construction Committee "On priority measures to implement the Address of the President of Ukraine to the Verkhovna Rada of Ukraine" Ukraine: entry into the XXI century. Strategy of economic and social development for 2000-2004 "from 1.3.2000, № 39.

Experimental studies to study the work of reinforced concrete pre-stressed combined sprung structures [23], [30], [31], as well as further theoretical analysis of these studies convincingly confirmed their greatest effectiveness in both operational and technical and economic indicators.





Simultaneously with the experimental design work [69, 70], theoretical substantiations were developed, as a result of which a new approach to the calculation of reinforced concrete pre-stressed combined sprung structures and qualitative assessment of structural elements taking into account various physical and mechanical factors that to some extent affect the redistribution of forces.



**CHAPTER 2**  
**SCIENTIFIC PART**



## 2. Scientific part

### Trusses pre-stressed by tendons

#### 2.1. Arrangement and design of trusses pre-stressed by tendons

**Truss design and location of tendons.** Among the techniques for pre-stressing trusses, the best developed one, similarly to beams, is by tendons made of high-strength materials. There are greater possibilities for varying the designs of trusses than those of beams, and therefore, the effectiveness of pre-stressing depends to a substantial degree upon judiciously chosen (with due regard for specific conditions) designs of the truss and of the tendon and upon the sequence of pre-stressing.

By location of tendons and their effect upon the behavior of the structure, pre-stressed trusses may be divided into two main types: first, trusses wherein tendons are located within the limits of the most stressed bars (Fig.2.1a) to pre-stress these bars only and, second, trusses in which tendons are located throughout or part of the span to pre-stress several or all of the truss bars (Fig.2.1b through g).

Trusses of the second type allow greater diversification of constructional patterns and are generally more effective.

In trusses of the first type, each bar is stressed in compression by its individual tendon. Static calculation of trusses is performed without taking into account the pre-stress [10], [11].

Pre-stressed trusses of this type are effective for large both spans and loads only, when each of the pre-stressed bars is an individual prefabricated unit. These bars are pre-stressed in the course of fabrication or during pre-assembly at the erection site. Each of the pre-stressed bars may provide a saving on metal of about 40 to 45%, but the economy of metal as regards the whole of the truss is 8 to 10%, and that of the cost, 6 to 10%. The greater both the span and the load upon the truss, the larger the obtainable economy.



Trusses of this type are more complicated in design, require a greater number of tendon anchorings, and their bars in tension are more labour-consuming to manufacture, but this may not be necessarily a prohibitive factor when industrial fabrication is contemplated [22], [55].

A simplest pattern of trusses of the second type is obtained when one or several tendons are arranged along the bottom chord in tension (Fig.2.1b through e). A single tendon pre-stresses several panels of the chord within its length, but the other bars remain unstressed. In large spans, when the forces active in the panels of the bottom chord are of a considerable magnitude, it is good practice to provide two tendons (see Fig.2.1.c). The middle panels, designed to take up a greater proportion of the load, are then pre-stressed in a manner to obtain a greater relieving effect, — and the material therein is thus used with greater efficiency [7], [9].

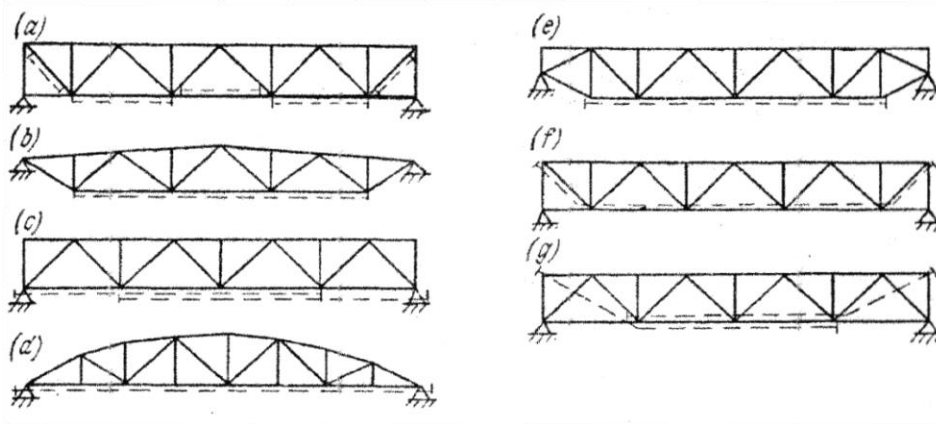

**Fig.2.1. Trusses with tendons within truss dimensions**

The pre-stress in a uniform pre-stressing of the whole of the bottom chord by a single tendon is limited by the compressive resistance of the extreme panels. Such a location of the tendon is possible in trusses of relatively small spans and constant chord cross section.

It is preferable to tension tendons before trusses are lifted in place. Tendons are connected throughout their lengths to the chord by diaphragms spaced at intervals of 40 to 50 of least radii of inertia of the chord cross section to ensure stability of the chord in the



course of pre-stressing. The number of strands tendon is a function of chord cross-section shape. It is more convenient to have a single strand (Fig.2.2d, e, f, g and Fig.2.3c) to reduce the number of anchorings. Whenever two strands are necessary (Fig.2.2a, b, c and Fig.2.3a and b), they should be symmetrical with respect to the centre of gravity of the chord cross section [8], [13].

Placement of a tendon along the bottom chord converts the truss into a statically indeterminate system. Therefore, single-span trusses with a single tendon should be calculated as once statically indeterminate systems. The economy of material in these trusses amounts to about 10 to 12%.

A greater economy in terms of mass – of about 12 to 16% – is obtainable by pre-stressing the bottom chord in segmental trusses (see Fig.2.1.d) in which the mass of the lattice is negligible, that of the bottom chord attains 40 to 50% of the mass of the whole truss, and the force along the bottom chord remains practically invariable.

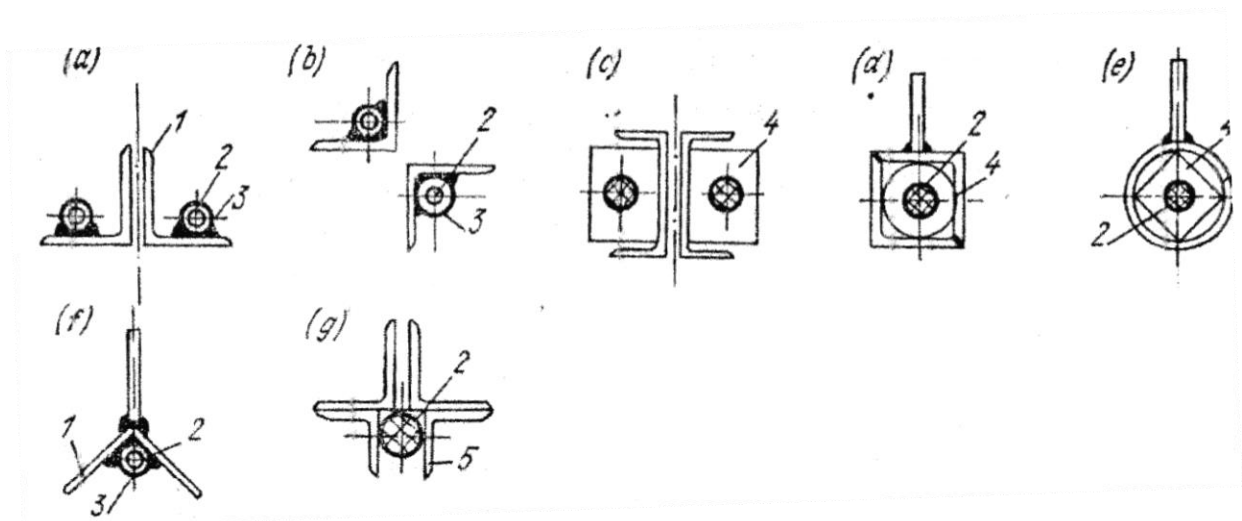

**Fig.2.2. Location of tendons in light trusses**

**1 – bar; 2 – tendon; 3 – short piece of pipe; 4 – diaphragm; 5 – short pieces of angles**

When tendon, located along the bottom chord, is anchored at the bearing and the spans are large (this involving considerable deformations of the bottom chord), the action of a temporary load may result in great horizontal displacements of the bearings (see Fig.2.1.c). This complicates the designing of bearing assemblies and leads to undesirable



deformations of the structure in service [14]. Deformations may be avoided by locating the bearings level with the neutral axis of the truss and fastening the tendon to a bottom chord joint which is the first from the bearing (see Fig.2.1.e).

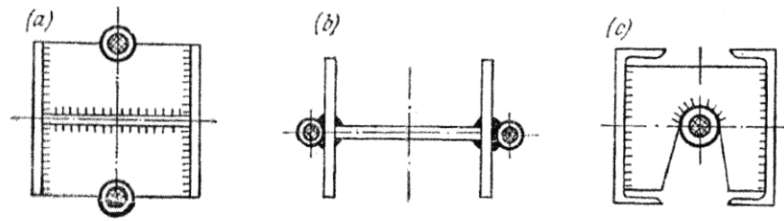

**Fig.2.3. Location of tendons in heavy trusses**

Pre-stressing efficiency is greater for the deflected (trussed) type of tendons (see Fig.2.1.g). In this case the tensioning of a single tendon may provide pre-stressing in a greater number of bars.

When a deflected tendon is located within the truss dimension (see Fig.2.1.f and g), the load-relieving pre-stress is obtained in the bottom chord and in the lattice bars located within the sloped section of the tendon (Fig.2.4.). Compressive forces in the extreme panels of the top chord due to pre-stressing have no tangible effect, if the top chord is of a constant cross section throughout the span [12].

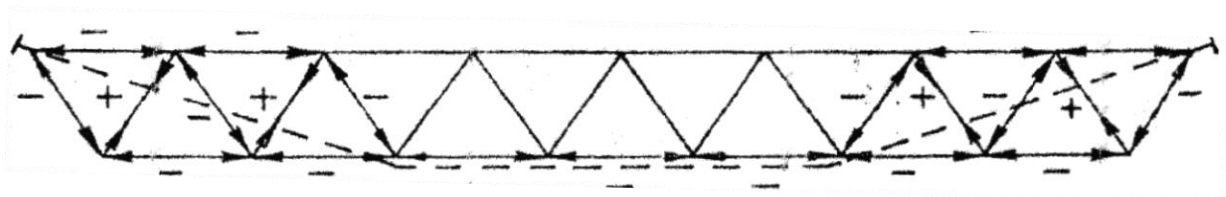

**Fig.2.4. Signs of pre-stressing forces in truss bars in the course of tensioning the trussing tendons**

A considerably greater economy of metal (25 to 30%) is obtainable by means of a trussed tendon which is built out of the truss (Fig.2.5.).



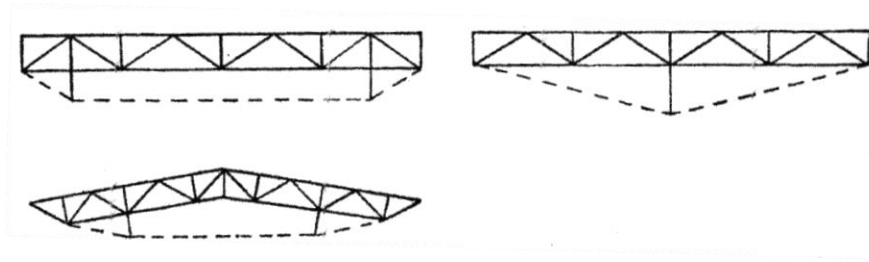

**Fig.2.5. Trusses with built-out tendons**

The optimum elevation of the tendon may be determined by the formula derived with a view to find a minimum volume of metal in a truss as a function  $h_2$ :

$$h_2 = \sqrt{h_1 + \frac{a \left( \frac{\psi h_1 l_1}{\varphi_i r} + \frac{l_2}{\alpha} \right)}{2 \left( \frac{1}{\alpha} + \frac{1}{\varphi_{tr}} \right)}} - h_1 \quad (2.1)$$

Where  $\psi$  = coefficient allowing for variable cross section of the top chord ( $\psi \leq 1$ )

$\varphi_i$  = coefficient of buckling of the middle panel of the top chord

$\varphi_{tr}$  = coefficient of buckling of trussed reinforcement strut

$a = R_{td} / R$  = ratio of design resistances of the tendon and the main metal

The remaining notations are given in Fig.2.6.

Height  $h_2$  calculated from formula (2.1) is approximately equal to (1.2 to 1.6)  $h_1$ , this increasing excessively the height of the whole structure. This is why height  $h_2$  is generally 20 to 30% less than its optimum value, from the design considerations.

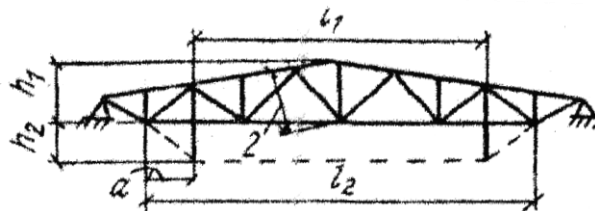
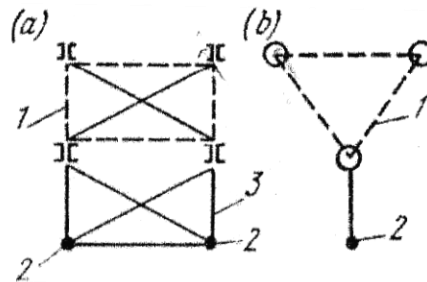

**Fig.2.6. Determination of the optimum height of a beam trussing rod**



A large economy of metal is due to the fact that stresses of the sign opposite to that from the load are produced in the bottom (compressive) and in the top (tensile) chords when tendons are tensioned [7].

The shortcoming of designs with built-out tendons lies in greater dimensions of trusses which are sometimes inadmissible.



**Fig.2.7. Joining of trusses into three-dimensional units with built-out tendons**

1 – trusses; 2 – tendons; 3 – braces

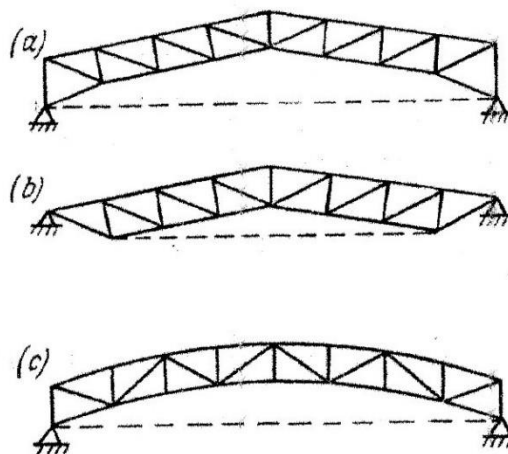

**Fig.2.8. Arch-type trusses**

Besides, the tendon is not connected to the bottom chord of the truss and thus fails to reinforce the latter against buckling in the course of pre-stressing. This practically precludes the tensioning of the tendon before it is set in place and requires either to tension the tendon after the truss is placed in design position and the bottom chords are braced against buckling or to erect the structure by means of twin trusses pre-assembled into a three-dimensional unit (Fig.2.7a). A similar procedure may be used to create a three-dimensional truss whose bottom chord will present an adequate stability against buckling





in the course of pre-stressing (Fig.2.7b). The three-chord system can readily be manufactured of pipes [15].

The design of a truss with a built-out tendon is more complicated because of auxiliary struts to support the tendon and a more involved bearing assembly with a tendon anchoring.

Numerous investigations tend to indicate that most effective are arch-type pre-stressed trusses with tendons (Fig.2.8); the trusses have an arched bottom chord and a straight tendon throughout the length of the span (Fig.2.8a and c) or part of its length (Fig.2.8b). Pre-stressing is then, as in the case of a built-out tendon, created by tensioning the tendon in all the bars of the truss. However, the truss overall dimensions are not increased. The effectiveness of the truss greatly depends on a judiciously chosen configuration, slope of chords, lattice pattern and other factors.

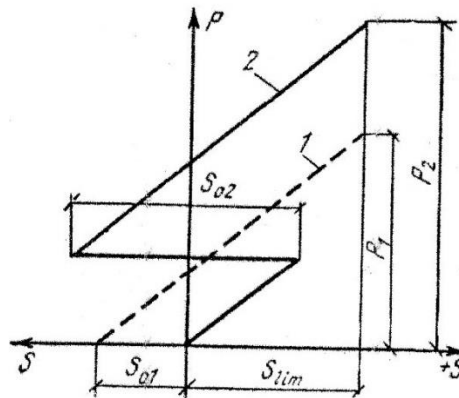

**Fig.2.9. Diagrams of a truss behavior**

**1 – with pre-stressing prior to loading; 2 – with pre-stressing after loading**

The optimum height of the truss at mid-span, from the tendon to the top chord, amounts to  $\frac{1}{6}$  to  $\frac{1}{8}$  of the span, while the height of the rigid truss is assumed to be  $\frac{1}{10}$  to  $\frac{1}{12}$  of the span. The height of the rigid portion of the truss may be reduced to ( $\frac{1}{20}$  to  $\frac{1}{40}$ ) of span  $l$  in case of multi-stage tensioning and in arched trusses of round or polygonal configuration.



The bottom chord, compressed in the course of pre-stressing, is prone to buckling, and, therefore, similarly to the trusses of the type above, the tendons are tensioned after the trusses are placed in the design position or assembled in three-dimensional units.

There are numerous possibilities for varying the arrangement of arch-type trusses.

The largest roofs of industrial buildings with pre-stressed trusses built in the Soviet Union are composed of arched trusses, as the roof of laboratory building in Sverdlovsk, the Reftinsk Power Station, the roof an industrial building in Minsk.

The effectiveness of pre-stressing of trusses depends to a greater degree on the sequence of tensioning and of loading of the truss.

Tensioning the tendon, with the structure in design position and part or all of the constant load applied to the truss, gives, generally, a greater effect than tensioning prior to loading of trusses (Fig.2.9).

It is best to tension the tendons in the sequence below. A truss with a tendon is placed in the design position, and then loaded with part of or full constant load. At this stage the tendon stresses itself by operating as part of the truss considered a statically indeterminate system [22]. Next, the tendon is tensioned to cancel partly or fully the force in the bars due to the constant (dead) load, after which the balance of the constant load and the temporary (live) load or the temporary load only are applied to the truss.

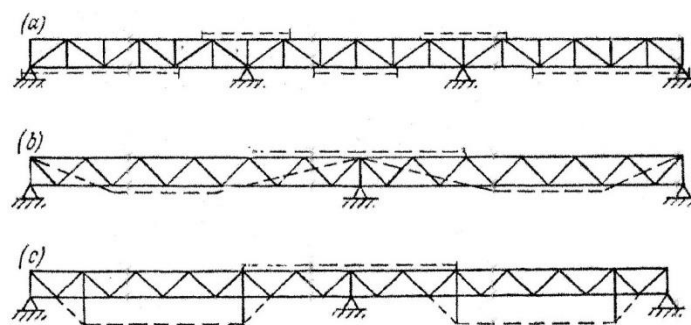

**Fig.2.10. Location of tendons in continuous trusses**



This sequence of tensioning provides a possibility certain degree a two-stage tensioning and to make use of its benefits (see Fig.2.9). The load-carrying capacity of the truss than increases, but a stronger tendon is required.

Experimental designing has shown that the “arch-and-tendon” type of trusses with adequately chosen both sequence of tensioning and tensioning force made possible a saving on steel of 25 to 30%. A largest economy of steel is obtainable with multi-stage tensioning of the tendon.

In continuous trusses the straight tendons should be located along the chord stretches in tension (Fig.2.10a). Use can also be made of deflected (within the truss dimension), built-out and other systems of tendons (Fig.2.10b and c).

Pre-stressing makes it possible to create an absolutely different type of truss in which all or almost all bars are of steel wire ropes or strands of high-strength wire. This type of trusses is particularly suited for large spans, as the pre-stressed bars are capable of taking up compressive stresses due to the load [23].

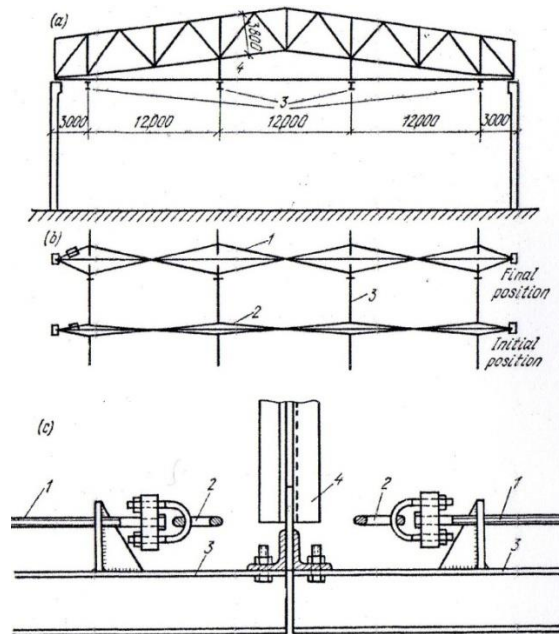

**Fig.2.11. Pre-stressing of trusses and of suspended crane girders by looped tendons by drawing them out of the truss plane**

**1 – tensioning bolt; 2 – tendon; 3 – crane girder; 4 – suspension**



Most various patterns of combined pre-stressing of transversal and longitudinal roof members in bar-type structures of building roofs are possible.

An interesting example is the structure of the roof of an industrial building equipped with four suspended multi-bearing single-girder cranes of 5-ton capacity (Fig.2.11a). “Arch-and-tendon” type of trusses, 42 m in span, are built at 6-m pitch. The single-girder cranes built of rolled I-beams are suspended to truss joints at the same level as the tendon [30]. A looped-type tendon is secured to the end anchoring on the bearing assemblies of the trusses, then passes from one truss to another, being fastened at the top chords of crane girders and forming “figure eight” configurations (Fig.2.11b).

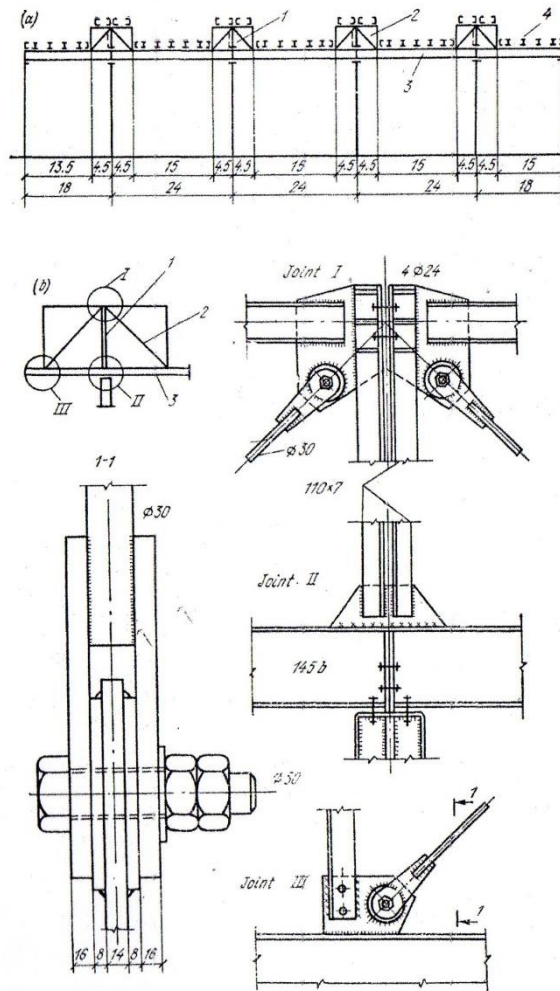

**Fig.2.12. Pre-stressed roof of an industrial building**

**a) Cross-section; b) detailed view of joints;**

**1 – skylight trusses; 2 – suspensions; 3 – cross bars or beams; 4 – purlins**



The tendon is tensioned at the top by guying the strands and securing them to the top chords of crane girders. The tendon may be tensioned and secured with a force of 100 to 120 kN manually with the aid of bolts and hooks (Fig.2.11c) or, if the forces involved are greater in value, by any other suitable means. Once tensioned and secured, the tendons cause compressive forces in the bearing assemblies of the trusses to relieve the top and bottom chords of the truss. Tensile forces in the top chord and compressive forces in the bottom chord arise at the points where the tendon is secured to the crane girders with the effect that all of the system (trusses, tendons and crane girders) are thus pre-stressed [40]. In such a system it is easy to effect pre-stressing and to tension the tendon if it weakens. A lesser tensioning force is required than in tensioning of straight tendons.

A team of the Byelorussian Polytechnical Institute conducted successful tests of experimental trusses with the above tensioning system. Total economy of metal in trusses and beams amounted to 20 to 25%.

Another example is a pre-stressed Suspended beam system (Fig.2.12). This system can readily be manufactured of rolled beams, and its advantage lies in an economy of steel.

In a building with columns arranged in a 24x12 or 30x12m network, the longitudinal skylights are located along the axes of columns. Skylight braces serve as suspensions that support the rolled cross-bar beams which receive purlins for the roofing. Tensioning of skylight suspensions converts the cross-bar beams into three-span systems in which the bending moments in the middle span (positive) and at points where suspensions are fastened (negative) level off. This reduces the value of the bending moments by a factor of 2 to 3 as compared to that in single-span cross-bars. The three-span cross-bars are the site of substantial longitudinal forces, which are compressive in the extreme spans and tensile in the middle span. The skylight suspensions may be tensioned by tightening bolts of two halves of the skylight truss in the top joint (Fig.2.12b) [41], [50].



Experimental designing has shown that lightweight pre-stressed trusses, 30 to 36 m in span, are best built of formed thin-walled square or rectangular sections or of pipes, as their high buckling resistance allows greater pre-stresses.

The use of formed sections of high-strength steel as bars in pre-stressed trusses ensures an economy of up to 45% of metal and a saving in costs of up to 35% [169].

When designing and manufacturing trusses it is essential to ensure solid coupling of the tendon to the chord at points where the diaphragms are placed in the order to prevent buckling of the chord in the course of pre-stressing [53].

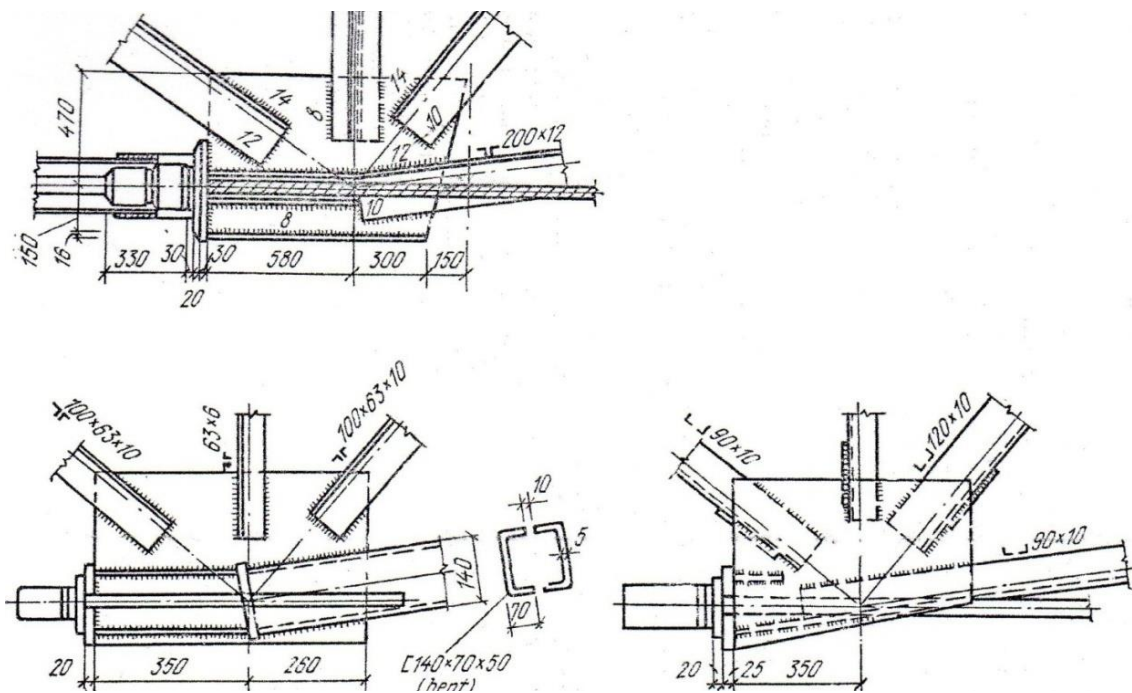

**Fig.2.13. Joints with anchor fastening of the tendons**

**Truss design.** All types of tendons and anchoring discussed in chapter one may be used in pre-stressed trusses. Best investigated is the use of tendons of steel wire ropes with sleeve-type anchorings.

Joints where bars (pre-stressed by individual tendons) meet differ in design from joints of customary trusses. Each bar carries at its end face a tendon anchoring which is required to be compact. The bars are connected to the joint plates with the aid of welding, rivets or bolts. At the joints, the bars should be reinforced by cover plates to allow effective transmission of the force from the tendon to the joint plate. An overlapping



tendon (see Fig.2.1c) may be secured along the span with the aid of a strong diaphragm which serves as an anchoring for one tendon and carries holes for the passage of another tendon [14]. Connection of the tendon to the truss bearing assembly may overload, similarly to beams, the joint and, in consequence, the latter should be of an adequate stiffness (Fig.2.13). Tests on an experimental beam tend to indicate that it is precisely the joint where failure occurs. Bends of tendons should be provided with adequate supports to ensure a smooth change of direction.

**Pre-stressed trusses of aluminium alloys.** The problem in the design of pre-stressed trusses of aluminium alloys is their low modulus of elasticity and the necessity to minimize truss deflections. It is particularly difficult to obtain a required rigidity in large span trusses carrying considerable temporary (live) loads (as, overhead transport), since deflection cannot be then cancelled by arching. Increasing the height of the truss to enhance its rigidity is a poor means, as it leads to a substantially greater consumption of metal because of heavier compressed bars of the lattice. In addition, it increases the volume of the building, and, in consequence, its initial and operating costs [7], [8], [15].

The most effective means to reduce deflections in trusses of aluminium alloys is to use pre-stressing, in particular, a multistage one. It is good practice to pre-stress single-span trusses by tendons of steel wire ropes or high-strength wires which feature a greater modulus of elasticity and are stronger and cheaper than formed sections of aluminium alloys by respectively 4 to 7 and 4 to 5 times.

Analysis shows that in contrast to pre-stressed steel trusses in which the drop in the consumption of steel always surpasses that of the costs (in terms of per cent), the cost of trusses from aluminium alloys falls off at a faster rate than the consumption of materials. Thus, pre-stressing of a 45-m roof truss by a tendon has reduced the truss mass by 23%, and its cost, by 32%.



## 2.2. Calculation of the trusses

Static calculation of trusses with individual pre-stressed bars is performed with no allowance for pre-stressing. The cross section of pre-stressed bars in tension is chosen on the value of the calculated force as indicated in Chapter Three.

Trusses with tendons that pre-stress several bars at a time are calculated as statically indeterminate systems. In the main system, the unknown is the force in the tendon. Calculation is effected by the approximation method.

First, it is necessary to assume the values of bar and tendon cross sections. Generally, when calculating  $n$  times a statically indeterminate truss with  $k$  tendons, the truss becomes  $(n + k)$  times statically indeterminate. The additional unknowns of the principal system are assumed to be the forces in tendons,  $X$ , and the forces  $Z$  in the additional bars of the truss.

Standard equations for solving the system are:

$$\left. \begin{aligned} \delta_{11}X_1 + \delta_{12}X_2 + \dots + \delta_{1z_1}Z_1 + \delta_{1z_2}Z_2 + \dots + \Delta_{1d} &= 0 \\ \delta_{21}X_1 + \delta_{22}X_2 + \dots + \delta_{2z_1}Z_1 + \delta_{2z_2}Z_2 + \dots + \Delta_{2d} &= 0 \end{aligned} \right\} (2.2)$$

Coefficients by the unknowns are calculated by customary formulas. When tendons are located within individual bars, the members with unknowns  $X$  are omitted in equations (2.2). The tendon cross-sectional area is considered a part of the bar cross-section.

When the statically indeterminate truss is assumed to be the principal system, the members with the unknowns  $Z$  are omitted from equations (2.2) and the unknowns in the equations will be the forces  $X$  in the tendons.

Pre-stressed arch-type trusses with a single tendon are best calculated by the method of specified forces, suggested by B.A. Speransky [12], [13], [14], [15].

Building practice indicates the following preferable sequence of operations: loading – tensioning of tendon – loading.





Whenever a tendon can be tensioned in the design position, the first loading consists in applying a part or all of the constant load. If tensioning is done on the trusses into twin three-dimensional units and to lift them into the design position after the tendons are tensioned. The first loading is then the dead weight of trusses and braces and, possibly, part of the roof structure. The second loading after the tendon is tensioned will be that part of the roof which is laid after the truss is placed in position and, additionally, the temporary load [23].

The principal system in arch-type trusses is more conveniently taken to be the rigid part of the truss with one additional unknown or the force in the tendon. The forces in bars due to full design load  $N_d$ ; erection load  $N_e$  which is active before the tendon is tensioned; and unit force  $N_1$  in the tendon are all determinate (usually by a graphical method) in the principal system. Next, a most stressed bar of the bottom chord (generally, one of the panels in the middle of the span) is found and taken to be the critical bar [39].

The cross-sectional area of the critical bar  $F_{cr}$  is determined on the basis of its ultimate flexibility  $\lambda = 120$  for a specified shape of cross section. The limit force in the critical bar is found from its cross-sectional area

$$N_{cr} = RF_{cr} \quad (2.3)$$

The design force in any bar  $i$  of the truss

$$N_i = N_{di} - N_{li}N_{td} \quad (2.4)$$

Where  $N_{td}$  = design force in tendon

$N_{di}$  = force in bar  $i$  of the principal system due to full design load

$N_{li}$  = force in bar  $i$  due to unit force in the tendon the design force for the critical bar

$$RF_{cr} = N_{cr} - N_{lcr}N_{td} \quad (2.5)$$

whence the force in the tendon



$$N_{td} = \frac{N_{cr} - RF_{cr}}{N_{1cr}} \quad (2.6)$$

And the tendon cross-sectional area

$$F_{td} = \frac{N_{td}}{R_{td}} \quad (2.7)$$

$N_{cr}$  is the critical bar force in the main system.

Knowing  $N_{td}$ , from formula (4) it is possible to determine the forces and then the cross-sectional areas of all the bars of the truss.

The full force in the tendon  $N_{td}$  adds up of the pre-stressing force  $X$  and of the self-pre-stress  $X_1$ .

The self-stressing force is found from the formula

$$X_1 = \frac{\sum \frac{N_{1i} N_{di}}{EF_i} l_i}{\sum \frac{N_{1i}^2 l_i}{EF_i} + \frac{l_{td}}{E_{td} F_{td}}} \quad (2.8)$$

Where  $l_{td}$  and  $E_{td}$  are respectively the length and the modulus of elasticity of the tendon.

The tendon pre-stressing force

$$X = N_{td} - X_1 \quad (2.9)$$

The load-carrying capacity of truss bars as regards design service loads is finally checked from the formulas below.

For bars in which the forces in the principal system due to the design load and to the tensioning of the tendon are of opposite signs, we have:

(a) Bars in compression when calculating the principal system for service loads:

When  $N_{di} > N_{Xi}$



$$N_{di} - (n_2 X + X_1)N_{li} \leq m\phi R_1 F_{gri} \quad (2.10)$$

When  $N_{di} < N_{Xi}$

$$N_{di} - (n_2 X + X_1)N_{li} \leq mR_1 F_{nti} \quad (2.11)$$

(b) Bars in tension when calculating the principal system for service loads:

When  $N_{di} > N_{Xi}$

$$N_{di} - (n_1 X + X_1)N_{li} \leq mR_1 F_{nti} \quad (2.12)$$

When  $N_{di} < N_{Xi}$

$$N_{di} - (n_1 X + X_1)N_{li} \leq m\phi R_1 F_{gri} \quad (2.13)$$

For bars in which the forces in the principal system due to the design load and to the tensioning of the tendon are of like signs, we have:

(a) bars in compression

$$N_{di} + (n_1 X + X_1)N_{li} \leq m\phi R_1 F_{gri} \quad (2.14)$$

(b) bars in tension

$$N_{di} + (n_1 X + X_1)N_{li} \leq mR_1 F_{nti} \quad (2.15)$$

The strength of the tendon is checked by means of the formula

$$n_1 X + X_1 \leq mR_{td} F_{td} \quad (2.16)$$

For individual bars in which the force in the principal system, due to the load, is less than the force due to the tensioning of the tendon (pre-stressing plus self-stressing), it may become necessary to check the load-carrying capacity not for design, but for the rated loads.

In formulas (2.10) through (2.16):

$N_{li}$  = force in bar  $i$  due to unit force in the tendon



$N_{xi}$  = force in bar  $i$  due to tensioning of the tendon

$\varphi$  = coefficient of buckling, whose value is assumed on maximum flexibility

$F_{gr}, F_{nt}$  = full and weakened cross section of the bar (gross and net)

When determining the flexibility, the free length of bars not connected longitudinally by diaphragms to the tendon is found according to customary rules. When a tendon is arranged along the length of the bar, its free length is assumed equal to the distance between the points of connection of the tendon to the bar. However, as tendons generally bear loosely upon the diaphragms, it is advisable to assume the free length 10 to 20% greater than the distance between the diaphragms [7].

Besides the service loads, trusses should also be calculated for loads active in the course of pre-stressing.

The consumption of metal and the cost of the truss depend on the force in the tendon. There are several methods for finding the optimum value of the force in the tendon on the basis of minimum either consumption of metal or cost of the truss, but these methods are too complicated for practical use. Various aspects of calculation of trusses pre-stressed by tendons are considered in greater detail in a book by B.A. Speransky.

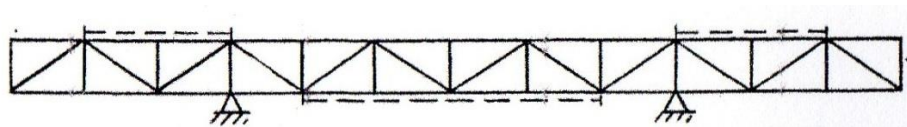

**Fig.2.14. Truss with independent loading of tendons**

If a truss comprises  $n$  tendons which are tensioned one after another, the tensioning of one of the tendons affects the values of the forces in all of the previously tensioned tendons. This does not apply to trusses in which each bar is pre-stressed by an individual tendon or to systems in which each tendon operates independently of the others (Fig.2.14).

In order to obtain a force  $X_i$  in the  $i$ -th tendon, it should be tensioned, account taken of the decrease in value of  $X_i$ , by a force



$$N_i = X_i + \sum_{i+1}^n \Delta X_{it} \quad (2.17)$$

Where  $\sum_{i+1}^n \Delta X_{it}$  is the sum of losses in the  $i$ -th tendon due to the tensioning of all the subsequent  $t$  tendons ( $i+1, i+2, \dots, n$ ).

Losses in force values due to the tensioning of all of the tendons, the first one excepted, are found by setting  $n - i$  systems of equations. Thus, it is necessary to determine values  $\Delta X_{12}$ ,  $\Delta X_{13}$  and  $\Delta X_{23}$  when a truss with tendons is involved, where  $\Delta X_{12}$  = loss in the force in the first tendon due to the tensioning of the second tendon is found from the equation

$$\delta_{11} \Delta X_{12} + \delta_{12} N_2 = 0 \quad (2.18)$$

$\Delta X_{13}$  and  $\Delta X_{23}$  = loss in the forces in the first and the second tendons due to the tensioning of the third tendon is found from the equations

$$\left. \begin{aligned} \delta_{11} X_{13} + \delta_{12} X_{23} + \delta_{13} N_3 &= 0 \\ \delta_{21} X_{13} + \delta_{22} X_{23} + \delta_{23} N_3 &= 0 \end{aligned} \right\} \quad (2.19)$$

Displacements  $\delta_{it}$  and  $\delta_{ii}$  are determined from the formulas

$$\left. \begin{aligned} \delta_{it} &= \sum \frac{\bar{N}_{ki} \bar{N}_{kt}}{E_k F_k} l_k \\ \delta_{ii} &= \sum \frac{\bar{N}_{ki}^2}{E_k F_k} l_k + \frac{l_i}{E_{tdi} F_i} \end{aligned} \right\} \quad (2.20)$$

Where  $\bar{N}_{ki}$  = force in bar  $k$  due to unit force in tendon  $i$  of the system considered

$\bar{N}_{kt}$  = force in bar  $k$  due to unit force in tendon  $t$

$E_k, F_k, l_k$  = modulus of elasticity, cross sectional area and length of bar  $k$

$E_{tdi}, F_i, l_i$  = modulus of elasticity, cross sectional area and length of tendon  $i$



We thus obtain the losses in forces in tendons  $\Delta X_{12}$ ,  $\Delta X_{13}$  and  $\Delta X_{23}$  from equations (2.18) and (2.19).

### 2.3. Trusses with multi-stage pre-stressing

**Basic features.** When pre-stressing is effected in a number of stages, it is possible to distribute at each stage the forces brought into play from the truss chords onto the tendon and so effect a sizable reduction in the mass of the structure. Multi-stage pre-stressing of trusses is particularly advantageous, as the trusses often admit of no considerable single-step pre-stress because of a great flexibility of bars compressed in the course of pre-stressing. This concerns both arch-type trusses and ones with a built-out trussed reinforcement in which bars, compressed in the course of pre-stressing, are not supported longitudinally by tendons.

Naturally, repeated loading of a material in tension and compression is possible if it is stressed within the elastic range only. Therefore, multi-stage pre-stressing is usable under the conditions below:

- (a) constant loads are large and can be transmitted upon the truss in separate portions;
- (b) structure members are approximately equal in tensile and compressive resistances (bars of a low flexibility);
- (c) structure's pattern admits of multi-stage pre-stressing.

It is well to remember the following requirements upon the design pattern of the truss which stem from the particularities inherent in multi-stage pre-stressing:

- 1) Maximum forces due to both loading and pre-stressing should arise in the same truss bars.
- 2) Least difference between the stresses in the chords due to loading and pre-stressing.



- 3) Least number of bars of like sign stresses from both loading and pre-stressing.  
The bars should be preferably in tension.

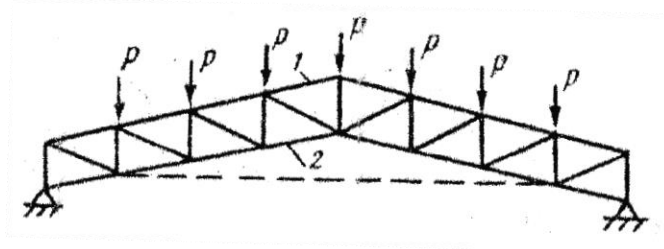

**Fig.2.15. Determination of the stress difference coefficient**

The second of the three requirements governs the possible number of pre-stressing steps and the values of the pre-stress and of the external load. The number of steps depends on the value -of the coefficient of stress difference in bars of maximum stresses. Thus, for bars 1 and 2 (Fig.2.15) the coefficients of stress differences  $Q_1$  and  $Q_2$  are respectively equal to:

$$Q_1 = \frac{N_2^x - N_1^x}{N_2^x} \quad (2.21)$$

$$Q_2 = \frac{N_1^d - N_2^d}{N_1^d} \quad (2.22)$$

where  $N_2^x$  and  $N_1^x$  – forces in respective bars due to unit force in the tendon ( $N_2^x > N_1^x$ )

$N_1^d$  and  $N_2^d$  – forces in respective bars due to unit vertical load ( $N_1^d > N_2^d$ )

The smaller the magnitude of the coefficient  $Q$ , the greater number of possible pre-stressing steps. After a number of pre-stressing and loading steps the force  $N_i = \sum_{i=1}^n (N_i^x + N_i^d)$  in one or several bars approximates the magnitude of the load-carrying capacity which precludes further both pre-tensioning of the tendon and loading. If coefficients  $Q$  equal to zero, the number of steps is theoretically infinitely great. The difference in forces due to pre-stressing and to loading in a bar has no effect on the possible number of pre-stressing steps.



**Main formulas for calculating multi-stage pre-stressing.** Let us determine the basic parameters of multi-stage pre-stressing in application to arch-type trusses (see Fig.2.15). Table 2.1 gives the values of tensioning forces and the magnitudes of loads which cause maximum stresses in the check bars of the top and the bottom chords. Check bars are the ones in which the forces are the first to reach the limit load-carrying values for a bar when the latter is stressed in tension or compression by an external load [23].

When multi-stage pre-stressing is begun by tensioning tendon  $X_1$  to a maximum compressive force in the bottom chord, after which a load  $P_1$  is applied, whose value is ultimate as regards the compressive stresses, in the top chord (the tensioning-and-loading cycles then repeating themselves), it is possible in accordance with the relevant formulas from Table 2.1 to obtain general formulas for determining the values of loading and tensioning forces at any stage:

$$P_i = \frac{1}{C_t} (N_b k_1 + N_i) (k_1 k_2)^{i-1} \quad (2.23)$$

$$X_i = \frac{1}{C_b} (N_b k_1 + N_i) k_1^{i-2} k_2^{i-1} \quad (2.24)$$

where  $i$  is the ordinal number of a pre-stressing stage (tensioning or loading).

In formulas (2.23) and (2.24) the starting values of  $i$  are respectively unity and two.

For an initial tensioning of the tendon:

$$X_1 = \frac{N_b}{C_b} \quad (2.25)$$

It is readily apparent from formulas (2.23) through (2.25) that, values  $P$  and  $X$  are converging functions of coefficients  $k_1$  and  $k_2$  whose magnitudes are less than unity and greater than zero.

The greater the values  $k_1$  and  $k_2$ , the slower the convergence of functions of  $P$  and  $X$ .





The total load upon the truss is:

$$P = \sum P_i = \frac{1}{C_t} (N_b k_1 + N_t) \sum_{i=1}^{\infty} (k_1 k_2)^{i-1} \quad (2.26)$$

**Table 2.1**

| Forces in Chords at Each Stage of Prestressing and Loading |                         |                                       |  |  |   |   |                           |
|--|-------------------------|---------------------------------------|--|--|---|---|---------------------------|
| Forces in chords   | $X_1 = \frac{N_b}{C_b}$ | $P_1 = (N_b k_1 + N_t) \frac{1}{C_t}$ | $X_2 = \frac{1}{C_b} \times (N_b k_1 + N_t) k_2$ | $P_2 = \frac{1}{C_t} \times (N_b k_1 + N_t) k_2 k_1$ | $X_{td} = \frac{1}{C_b} \times (N_b k_1 + N_t) k_2^2 k_1$ | $P_{td} = \frac{1}{C_t} \times (N_b k_1 + N_t) k_2^3 k_1^2$ | $X_i = \dots P_i = \dots$ |
| In top chord for each stage                                | $+ N_b k_1$             | $-(N_b k_1 + N_t)$                    | $+(N_b k_1 + N_t) k_2 k_1$                       | $-(N_b k_1 + N_t) k_2 k_1$                           | $+(N_b k_1 + N_t) k_2^2 k_1^2$                            | $-(N_b k_1 + N_t) k_2^3 k_1^2$                              | ...                       |
| In bottom chord for each stage                             | $- N_b$                 | $+(N_b k_1 + N_t) k_2$                | $-(N_b k_1 + N_t) k_2$                           | $+(N_b k_1 + N_t) k_2^2 k_1$                         | $-(N_b k_1 + N_t) k_2^2 k_1$                              | $+(N_b k_1 + N_t) k_2^3 k_1^2$                              | ...                       |

*Notations:*  
 $X$  = prestressing force in tendon  
 $P$  = load value  
 $C_t$  = force in the check bar of the top chord due to unit loads  
 $C_b$  = force in the check bar of the bottom chord due to unit tensiioning  
 $N_t$  and  $N_b$  = load-carrying capacity in compression of the check bars of the top and bottom chords  
 $k_1 = 1 - Q_1$  = coefficient of relief of the top chord  
 $k_2 = 1 - Q_2$  = coefficient of relief of the bottom chord  
 $Q_1$  and  $Q_2$  = are determined with the aid of formulas (5.21) and (5.22)

The total force in the tendon, account taken of self-stressing,

$$\begin{aligned} X &= \frac{N_b}{C_b} + \sum_{i=2}^{\infty} X_i + \sum_{i=1}^{\infty} C_{td} P_i = \\ &= \frac{N_b}{C_b} + \frac{1}{C_b} (N_b k_1 + N_t) \sum_{i=2}^{\infty} k_1^{i-2} k_2^{i-1} + C_{td} \sum_{i=1}^{\infty} P_i = \\ &= \frac{N_b}{C_b} + (N_b k_1 + N_t) \left[ \frac{C_{td}}{C_t} \sum_{i=1}^{\infty} (k_1 k_2)^{i-1} + \frac{1}{C_b} \sum_{i=2}^{\infty} k_1^{i-2} k_2^{i-1} \right] \end{aligned} \quad (2.27)$$

where  $C_{td}$  is the force in the tendon due to unit loads.

Parameters  $N_t$  and  $N_b$  are functions of the loading and the geometric patterns of the truss. All the other parameters in formulas (2.23) through (2.27) are governed by the geometric pattern of the structure only [24].



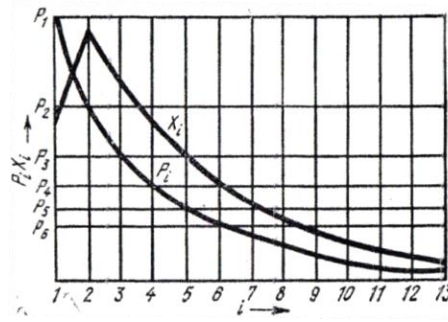

**Fig.2.16. Dependence of  $P_i$  and  $X_i$  on the ordinal number of loading and tensioning**

Formula (2.26) shows that the value of the total load is affected to a greater degree by the load-carrying capacity of the top chord  $N$ , than by that of the bottom chord  $N_b$ . Therefore, it is advisable to make the top chords stronger in this type of trusses.

Multi-stage pre-stressing may be effected until one of the chords is stressed to full bearing capacity.

The smaller the values of  $k_1$  and  $k_2$ , the faster the drop in magnitudes of  $P_i$  and  $X_i$ . The number of pre-stressing operations may be increased by decreasing the values of  $P_i$  and  $X_i$ .

Figure 2.16 shows the relationship between the value of the tendon pre-stressing load and its corresponding ordinal number.

Curve  $X - i$  begins with the ordinal number  $i=2$ , and for  $i=1$  force  $X_1$  is determined from formula (2.25).

Figure 2.17 illustrates curves  $P - i$  for the numerical values of the parameters in formula (2.23). The curves have been plotted by assuming  $C_t = N_b = 1$ ;  $N_t = 2$ . For one of the curves we have  $k_1 = k_2 = 0.8$ , and for the other,  $k_1 = 0.6$ ,  $k_2 = 0.8$ . The assumed numerical values are possible as regards multi-stage pre-stressing and favorable to it.



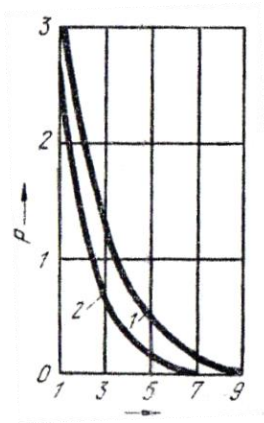

**Fig.2.16. Curves P – i for various values of  $k_1$  and  $k_2$**

$$1 - k_1 = k_2 = 0.8; \quad 2 - k_1 = 0.6; \quad k_2 = 0.8$$

The diagrams show a sharp drop in the value of the load for each of the subsequent loading stages. The drop in the value of coefficient  $k$  is paralleled by that of effective loadings. A major practical upshot from the present analysis is that three or four tensioning cycles suffice, as subsequent tensioning has no practical effect whatsoever [13], [14].

Consideration of formula (2.23) makes it possible to evaluate the effect of various factors upon the limit value of the load and the load in each cycle.

The values of the first loading and the sequence of loadings may vary to suit specific operating conditions. If the first loading is equal to the maximum possible force in terms of compressive capacity of the bottom chord,  $X_1 = X_0$ , then the ultimate load for a specified number of cycles ( $i=n$ ) is a constant and  $i$ 's thus not affected by the value of the load in an individual stage.

If the first loading cannot be fulfilled to its full extent for one reason or another, the load in the subsequent stages may be increased accordingly to bring the total load at the  $n$ -th stage to its required value. On the other hand, the value of the full load at the  $n$ -th stage depends on the load value in the first tensioning of the tendon. If the value in the first tensioning is smaller than  $X_0$ , the value of the full load on the  $n$ -th stage will also be lower.



Should the operating conditions permit tensioning the tendons after a first loading, the formulas for the multi-stage pre-stressing are transformed as follows:

The value tensioning for each stage  $i=2, 3, 4$

$$X_i = (N_b + N_t k_2) \frac{k_1^{i-2} k_2^{i-2}}{C_b} \quad (2.28)$$

The total force due to tensioning

$$X' = \sum X_i = \frac{1}{C_b} (N_b + N_t k_2) \sum_{i=2}^{\infty} k_1^{i-2} k_2^{i-2} \quad (2.29)$$

The value of load in each stage  $i=2, 3, 4$

$$P_i = (N_b + N_t k_2) \frac{k_1^{i-2} k_2^{i-2}}{C_b} \quad (2.30)$$

The value of first loading

$$P_1 = \frac{N_t}{C_t} \quad (2.31)$$

And the total load

$$\sum P = \sum_{i=2}^{\infty} P_i = \frac{N_t}{C_t} + \frac{1}{C_t} (N_b + N_t k_2) \sum_{i=1}^{\infty} k_1^{i-1} k_2^{i-2} \quad (2.32)$$

The total force in the tendon with regard for the self-stressing due to external load

$$\begin{aligned} X &= X' + C_{td} \sum_{i=2}^{\infty} p = \\ &= \frac{C_{td} N_t}{C_t} + (N_b + N_t k_2) \left[ \frac{1}{C_b} \sum_{i=2}^{\infty} (k_1 k_2)^{i-1} + \frac{C_{td}}{C_t} \sum_{i=2}^{\infty} k_1^{i-2} k_2^{i-1} \right] \end{aligned} \quad (2.33)$$

When the first and the second pre-stressing cases are compared (respectively,  $X_1 = X_0$  and  $X_1 = 0$ ), the following conclusions are possible.



The tensioning force at the  $i$ -th stage in the second case is greater than that in the first stage ( $X_1$  excepted).

The difference between the tensioning forces in each stage

$$\Delta X_i = \frac{N_b}{C_b} (1 - k_1 k_2) k_1^{i-2} k_2^{i-2} \quad (2.34)$$

The difference in the values of the total forces in the tendon

$$\Delta \sum X_i = \frac{N_b}{C_b} k_1^{i-2} k_2^{i-2} \quad (2.35)$$

With each subsequent stage this difference decreases and tends to zero at an infinite number of pre-stressing steps. With an infinite number of stages the total force in the tendon is the same in both cases. The value of the first loading in the first case is by  $(1/C_t)N_b k_1$  greater than that in the second case. And vice versa, the value of the corresponding loading stage in the first case in all the subsequent loadings is by a factor of

$$\frac{1}{C_t} N_b k_1 (1 - k_1 k_2) k_1^{i-2} k_2^{i-2}$$

less than that in the second case. The difference in the values of the total loads

$$\Delta P_i = \frac{N_b}{C_t} k_1^i k_2^{i-1}$$

decreases with each tensioning stage (Fig.2.18). An infinite number of tensionings leads to a same value of the load carrying capacity of the structure.

$$P_{\text{lim}} = \frac{N_t + N_b k_1}{C_t (1 - k_1 k_2)} \quad (2.36)$$



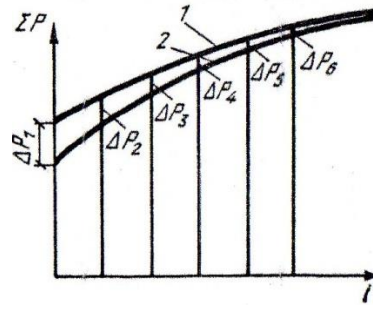

**Fig.2.18. Chart of total loads**

**1 – in the tensioning prior to loading; 2 – in tensioning after loading**

Therefore, the limit load-carrying capacity of the truss is governed by its design pattern, and, in the first place, by factors  $k_1$ ,  $k_2$  and  $C_t$

The load-carrying capacity of the top chord  $N_t$ , has a greater bearing upon the limit load value of the truss than the load-carrying capacity of the bottom chord  $N_b$ .

The maximum force in the tendon corresponding to the limit state of the truss:

$$X_{\max} = \frac{C_{td}(N_t + k_1 N_b)}{C_t(1 - k_1 k_2)} + \frac{N_b + k_2 N_t}{C_b(1 - k_1 k_2)} \quad (2.37)$$

The first member of formula (2.37) characterizes the action of the load, and the second, the tendon pre-stress. Parameter  $C_{td}$  should be preferably of a least value as feasible in order to reduce the cross-sectional area of the tendon and facilitate its tensioning.

Parameters  $C_t$  and  $C_b$  should be Considered from the viewpoint of their effect upon the increase in the load-carrying capacity of the truss [see formula (2.37)].

Parameter  $k_1$  incorporates value  $C_b$ ,

$$k_1 = 1 - Q_1 = 1 - \frac{C_b - C'_t}{C_b} = \frac{C'_t}{C_b} \quad (2.38)$$

where  $C'_t$  – force in the check bar of the top chord due to unit force in the tendon.



Load-carrying capacity of the truss may be enhanced by reducing the value of  $C_b$ , as  $k_1$  then increases.

Thus, the optimum design pattern of a multi-stage pre-stressed structure should have maximum values of relieving factors  $k_1$  and  $k_2$  and minimum values of parameters  $C_t$ ,  $C_b$  and  $C_{td}$ .

If intermediate values between the first and the second cases are considered, i.e., when  $X_0 < X_1 < 0$ , the nature of the stresses will be, in principle, the same as for the first case ( $X_1 < X_0$ ).

This is practically possible due to a limited capacity of the tensioning devices.

Due to a reduction in the initial tensioning  $X < X_0$  beginning with the second stage, the value of loading of the corresponding stage should be by  $\Delta P_i$  greater as compared to the same value when  $X_1 < X_0$ .

The difference in total loads will narrow with each loading stage and disappear after an infinitely great number of pre-stressing cycles. However, the load-carrying capacity will be greater for a finite number of cycles and  $X_1 = X_0$ , and, therefore, means should be provided to make  $X$  as closer as possible to  $X_0$ .

Consideration of coefficients  $k_1$  and  $k_2$  for various systems of trusses may indicate which one of the systems being compared will have a greater load-carrying capacity when pre-stressing is performed in progressive stages.

This procedure has shown [15] the arch-type pattern (see Fig. 2.8) to be the most effective one. In order to reduce the difference in stresses in the check bars and thus to increase the values of coefficients  $k_1$  and  $k_2$ , the distance between chords should be the least possible from design considerations while ensuring specified rigidity of the truss.



## Calculation

Calculate the values of tendon of tensioning forces and of forces due to external load for an arch-type truss (Table 2.2) subjected to a multi-stage test. First, it is necessary to assume, as for any statically indeterminate system, the cross sections and to determine the load-carrying capacity of bars of the top  $N_t$  and the bottom  $N_b$  chords (see two first columns in Table 2.2). The following columns of the table list the forces due to unit tensioning and to unit load.

It is readily apparent from Table 2.2 that the check bars will be the member f-g of the top chord and the member n-o of the bottom chord, in which  $C_t=13.57$  and  $C_b=4.34$ .

Compute coefficients of relief  $k_1$  and  $k_2$  for the check bars:

$$k_1 = 1 - Q_1 = 1 - \frac{4.34 - 2.71}{4.34} = 0.625$$

$$k_2 = 1 - Q_2 = 1 - \frac{13.57 - 5.46}{13.57} = 0.404 .$$

Calculate the tensioning forces from formulas (2.24) and (2.25):

$$X_1 = \frac{N_b}{C_b} = \frac{352}{4.34} = 81 \text{ kN}$$

$$X_2 = \frac{1}{4.34} (352 \times 0.625 + 395) 0.404 = 57 \text{ kN}$$

$$X_2 = \frac{1}{4.34} (352 \times 0.625 + 395) 0.625 \times 0.404 = 14.3 \text{ kN}$$





Table 2.2

Determination of Check Values of Tensionings and Loadings

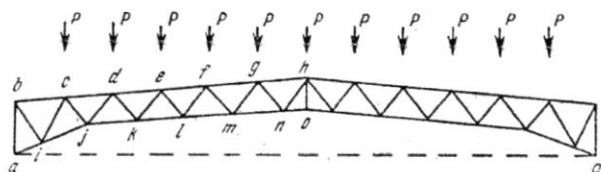

| Designation of bars | Capacity of bars in tension $mRF$ , kN | Capacity of bars in compression $m\phi'R$ , kN | Force from unit tensioning of tendon $N=1$ | Forces from unit loads $P=1$ | $X_1 = N_b/C_b = 81$ kN | $P_1 = \frac{395+219}{13.57} = 45.2$ kN | Total force, kN | $X_2 = \frac{352-105}{4.34} = 37$ kN | $P_2 = \frac{154}{13.57} = 11.3$ kN | Total force, kN | $X_3 = \frac{352-290}{4.34} = 14.3$ kN | $P_3 = \frac{39}{13.57} = 2.9$ kN | Final force in bars, kN |
|---------------------|--|--|--|------------------------------|-------------------------|---|-----------------|--------------------------------------|-------------------------------------|-----------------|--|-----------------------------------|-------------------------|
| Top chords          |  |  |  |                              |                         |   |                 |                                      |                                     |                 |  |                                   |                         |
| <i>a-a'</i>         | +520                                   | —  | +1   | +5.71                        | -81                     | +268                                    | +349            | +57                                  | +64.5                               | +470.5          | +14.3                                  | +16.4                             | +501.2                  |
| <i>b-c</i>          | +483                                   | -395   | +0.4                                       | -1.82                        | +32.4                   | -82.3                                   | -49.9           | +22.8                                | -20.6                               | -47.7           | +5.7                                   | -5.3                              | -47.3                   |
| <i>c-d</i>          | +483                                   | -395   | +1.48                                      | -5.41                        | +120                    | -244                                    | -124            | +84                                  | -62                                 | -101            | +21                                    | -15.5                             | -95.5                   |
| <i>d-e</i>          | +483                                   | -395   | +1.89                                      | -9.38                        | +153                    | -424                                    | -271            | +108                                 | -106                                | -269            | +27                                    | -27                               | -269                    |
| <i>e-f</i>          | +483                                   | -395   | +2.3                                       | -12.12                       | +186                    | -549                                    | -363            | +131                                 | -137                                | -369            | -33                                    | -35                               | -371                    |
| <i>f-g</i>          | +483                                   | -395   | +2.71                                      | -13.57                       | +219                    | -614                                    | -395            | +154                                 | -154                                | -305            | +39                                    | -39                               | -395                    |
| <i>g-h</i>          | +483                                   | -395   | +3.12                                      | -12.46                       | +252                    | -564                                    | -312            | +177                                 | -141                                | -276            | +45                                    | -36                               | -267                    |
| Bottom chords       |  |  |  |                              |                         |   |                 |                                      |                                     |                 |  |                                   |                         |
| <i>a-i</i>          | +584                                   | -548   | -1.08                                      | -6.16                        | -87.5                   | -279                                    | -366.5          | -61.5                                | -69.6                               | -497.6          | -154                                   | -17.8                             | -531.8                  |
| <i>i-j</i>          | +584                                   | -530   | -1.89                                      | -2.45                        | -153                    | -110.8                                  | -263.8          | -107.8                               | -27.7                               | -399.3          | -27                                    | -7.1                              | -433.4                  |
| <i>j-k</i>          | +358                                   | -318   | -2.7                                       | +2.24                        | -218                    | +101                                    | -117            | -153                                 | +25                                 | -245            | -39                                    | +6                                | -278                    |
| <i>k-l</i>          | +358                                   | -318   | -3.11                                      | +4.96                        | -252                    | +224                                    | -28             | -177                                 | +56                                 | -139            | -45                                    | +14                               | -170                    |
| <i>l-m</i>          | +358                                   | -318   | -3.52                                      | +7.67                        | -285                    | +347                                    | +62             | -200                                 | +87                                 | -51             | -50                                    | +22                               | -79                     |
| <i>m-n</i>          | +358                                   | -318   | -3.93                                      | +7.86                        | -318                    | +355                                    | +37             | -223                                 | +89                                 | -97             | -56                                    | +23                               | -130                    |
| <i>n-o</i>          | +358                                   | -352   | -4.34                                      | +5.46                        | -352                    | +247                                    | -105            | -247                                 | +62                                 | -290            | -62                                    | +16                               | -336                    |

Calculate the loads upon a single joint with the aid of formula (2.23):

$$P_1 = \frac{1}{13.57} (352 \times 0.625 + 395)1 = 45.2 \text{ kN}$$

$$P_2 = \frac{1}{13.57} (352 \times 0.625 + 395)0.625 \times 0.404 = 11.3 \text{ kN}$$

$$P_3 = \frac{1}{13.57} (352 \times 0.625 + 395)(0.625 \times 0.404)^2 = 2.9 \text{ kN}$$

Value  $p_3$  is small, and it is evident that further tensioning and loading stages will be ineffective.

The total load upon the truss joint

$$\Sigma P = 45.2 + 11.3 + 2.9 = 59.4 \text{ kN}$$



The ultimate load upon the truss after an infinite number of pre-stressing cycles, as given by formula (5.36), is



$$P_{\text{lim}} = \frac{395 + 0.625 \times 352}{13.57(1 - 0.625 \times 0.404)} = 60.7 \text{ kN}$$

It is readily apparent that three loading stages suffice to exhaust fully the limit load-carrying capacity of the truss.

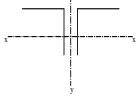
### Determination of cross-section of roof braces

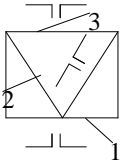
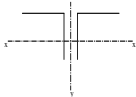
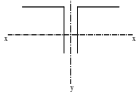
| Mark | Sketcher  | Designation | $\lambda_u$ | $l_x$   | $l_y$ | Necessary radiuses of inertia, cm |                           | Cross-section | Radius of inertia, cm |                           |
|------|---|-------------|-------------|---------|-------|-----------------------------------|---------------------------|---------------|-----------------------|---------------------------|
|      |   |             |             |         |       | $\frac{i_x}{i_y}$                 | $\frac{i_{x_0}}{i_{y_0}}$ |               | $\frac{i_x}{i_y}$     | $\frac{i_{x_0}}{i_{y_0}}$ |
| VB1  |    | -           | 30<br>0     | 62<br>1 | 1242  | $\frac{2.07}{4.14}$               | -                         | 2 L100·7      | $\frac{3.08}{4.45}$   | -                         |
| VB2  |  | -           | 20<br>0     | 32<br>9 | 657   | $\frac{1.65}{3.29}$               | -                         | 2 L75·5       | $\frac{2.31}{3.42}$   | -                         |
| VB3  |  | 1           | 20<br>0     | 27<br>5 | 550   | $\frac{1.38}{2.75}$               | -                         | 2 L63·5       | $\frac{1.94}{2.96}$   | -                         |
|      |   | 2           | 20<br>0     | 41<br>8 | 418   | $\frac{2.09}{2.09}$               | -                         | 2 L70·5       | $\frac{2.16}{3.23}$   | -                         |
|      |   | 3           | 20<br>0     | 55<br>0 | 550   | $\frac{2.75}{2.75}$               | -                         | 2 L90·7       | $\frac{2.77}{4.06}$   | -                         |
| LB2  |  | -           | 20<br>0     | 60<br>0 | 600   | $\frac{3.0}{3.0}$                 | -                         | 2 L100·7      | $\frac{3.08}{4.45}$   | -                         |
| LB3  |  | -           | 40<br>0     | 60<br>0 | 600   | $\frac{1.5}{1.5}$                 | -                         | 2 L50·5       | $\frac{1.53}{2.45}$   | -                         |

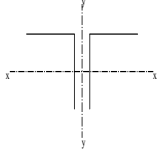
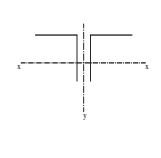
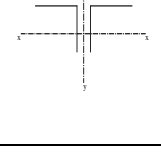

|     |   |   |         |         |     |                     |   |                |                     |   |
|-----|---|---|---------|---------|-----|---------------------|---|----------------|---------------------|---|
| LB5 |  | 1 | 40<br>0 | 84<br>9 | 849 | $\frac{2.12}{2.12}$ | - | 2 L75 · 50 · 5 | $\frac{2.39}{2.2}$  | - |
| VB4 |  | - | 20<br>0 | 32<br>5 | 650 | $\frac{1.63}{3.25}$ | - | 2 L75 · 5      | $\frac{2.31}{3.42}$ | - |
| LB4 |  | - | 20<br>0 | 33<br>6 | 671 | $\frac{2.13}{4.25}$ | - | 2 L100 · 7     | $\frac{3.08}{4.45}$ | - |

## 2.4. Experimental investigations of trusses

Numerous experimental investigations of trusses pre-stressed by tendons have been carried out these last two decades in the Soviet Union. Most of the investigations were performed at the S. M. Kirov Ural Polytechnical Institute by a team under B. A. Speransky [13], [14]. Trusses were also investigated at the Byelorussian Polytechnical Institute, the Moscow Construction Engineering Institute and others. Theoretical analysis has indicated the optimum truss pattern to be an arch with a tendon, and, therefore, a maximum number of tests were performed on trusses of the said pattern.

Tests were carried on models of trusses and on whole trusses under laboratory and field conditions, in the course of erection and service, with single and multi-stage pre-stressing. Truss bars and tendons with anchors were of various designs, but chiefly tested were steel trusses with tendons of steel wire ropes and sleeve anchors poured with a low-melting alloy. Tests also covered aluminium alloy trusses. Trusses were loaded generally by jacks with the aid of tensioning devices.

The aim of the tests was to compare the actual behaviour of trusses with the theoretical assumptions, to check various designs and to refine the pre-stressing techniques.



All methods for creating a pre-stress in experimental trusses, inclusive of multi-stage pre-stressing, were proved to be practically feasible.

On the whole, the tests have borne out the design assumptions and the possibility of calculating pre-stressed trusses with the aid of the proposed method. At the same time, the tests indicated some of the particularities of behaviour of pre-stressed trusses. Deviations between the calculated and the actual stresses and deflections of trusses were greater than in tests of customary single-span trusses. For the most part, this may be explained by the fact that pre-stressed trusses are more complicated systems than customary single-span trusses, as they are statically indeterminate, consist of two materials of different mechanical characteristics, are affected by the yielding of the tendon anchorings, and the stressed state of trusses adds up of two heterogeneous actions (pre-stressing and loading by an external load).

The tests have shown that the failure of pre-stressed trusses with tendons, designed of equal strength in all of their parts, occurs due to a loss of stability of bars in compression. A truss cannot lose its load-carrying ability due to breakage of the tendon, because, when the stresses exceed the design values, the modulus of elasticity of the tendon falls off, the stresses therein decrease, and the forces are transferred upon the truss chords. The linear regularity of the structure's behaviour no longer holds, and the bars in compression now stressed to a greater degree lose stability (buckle). This particularity is clear-cut in trusses with tendons of wire ropes pre-stretched before they are placed in the structure by a force that exceeds the design value by not more than 10 to 15%. As soon as the force in the tendon during the loading of the truss exceeds the wire rope stretching force, the increment of stresses in the tendon decreases sharply, but increases in the truss bars. Although a pre-stressed truss is a statically indeterminate system and the attainment of a limit state by a single bar does not entail necessarily the loss of the load-carrying capacity of the whole system, the fact is that after a bar in compression fails, the force in it drops sharply, all the forces then being so forth re-distributed among the other bars to cause stresses in excess of their load-carrying capacity with the effect that the truss



changes shape and fails. A similar occurrence was reported in six tests of statically indeterminate non-prestressed trusses incorporated in a system of double-span frames of industrial buildings [16].

Agreement of the design and the actual values of deflections were better than that of stresses. Generally, the deflections were less than their calculated values, and the design correction factors in the elastic range of behaviour, 0.85 to 0.95.

Breaking load in some of the trusses was by 5 to 9% less than its theoretical value, calculated with the aid of actual characteristics of the material with a wire rope tendon of the modulus of elasticity  $E = 0.16 \times 10^6 \text{ MPa}$ . A small drop in the actual value of the breaking load is due to the yielding of the tendon over the final loading stage and the resultant re-distribution of forces upon truss bars. The cross sections of truss bars have been chosen in a manner to bring the forces in the top chord and the tendon to their limit values simultaneously.

**Table 2.3**

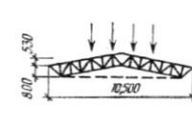
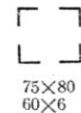
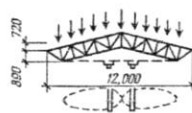
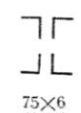
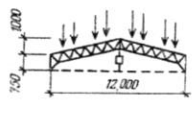
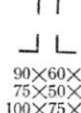
| Main Characteristics of Experimental Trusses |   |                                      |   |   |  |
|--|---|--------------------------------------|---|---|--|
| Type of trusses                              | Truss and loading pattern   | Type of tendon                       | Cross section of chords   | Tensioning and loading procedure  | Tests carried out by   |
| ΦY1  |  | None                                 |  | Loading   | S. M. Kirov Ural Polytechnical Institute and Industrial Construction Research Institute (Sverdlovsk) |
| ΦY2  |   | Steel wire rope. 17 mm in diameter   |   | Tensioning Loading  |  |
| ΦY3  |   | Same                                 |   | Tensioning Loading<br>Tensioning Loading                                  |  |
| ΦY4  |   | Steel wire rope. 22.5 mm in diameter |   | Same  |  |
| ΦБ1  |  | Same, 23.5 mm in diameter            |  | Loading<br>Tensioning Loading<br>Tensioning Loading<br>Tensioning Loading | Byelorussian Polytechnical Institute (Minsk)   |
| ΦБ2  |   | Same                                 |   | Same  |  |
| ΦM1  |  | Strand of wire. 5 mm in diameter     |  | Tensioning Loading<br>Tensioning Loading<br>Tensioning Loading            | V. V. Kuibyshev Construction Engineering Institute and TsNISK (Moscow)                               |
| ΦM2  |   | Same                                 |   | Tensioning Loading  |  |



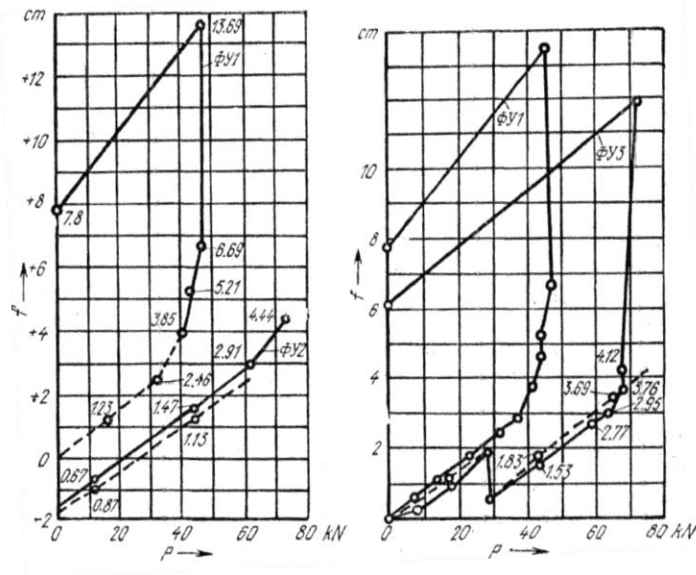

**Fig.2.19. Deflections of  $\Phi Y1$  and  $\Phi Y2$  trusses**

calculated values; experimental values

Characteristics of some of the tested trusses are given in Table 2.3.

Figure 2.19 compares deflections of trusses  $\Phi Y1$  without tendon with those of trusses  $\Phi Y2$  and  $\Phi Y3$  pre-stressed by a tendon. The charts show clearly a good agreement of the calculated and the actual values of deflections in the elastic range and a considerable increase in load-carrying capacity of trusses  $\Phi Y2$  and  $\Phi Y3$ . After pre-stressing and loading, the load-carrying capacity of truss  $\Phi Y3$  (Fig.2.19) has not increased with respect to truss  $\Phi Y2$ , but deflections under limit load fell by 20% (Fig.2.19). Trusses in which tendons had an additional margin of strength were made of a straight strand of high-strength wire and carried the load at a constant modulus of elasticity until failure occurred, and their actual load-carrying capacity was somewhat higher than its theoretical value.

The tests have made clear some of the particularities of behaviour of trusses in the course of pre-stressing. When pre-stressing a truss in situ, it is necessary to provide freedom of deformation for the whole of the truss, inclusive of free horizontal motion of bearing assemblies. If friction is considerable on the bearings, pre-stress is partly lost. Due to tensioning losses in the tendon, the actual forces in the cross stays and chords when loading a truss were by 20 to 25% higher than the calculated values. Similarly to beams,



the tendon fastening assembly, particularly if it is combined with the truss bearing assembly, takes up large forces and should be designed and manufactured with great care [53].

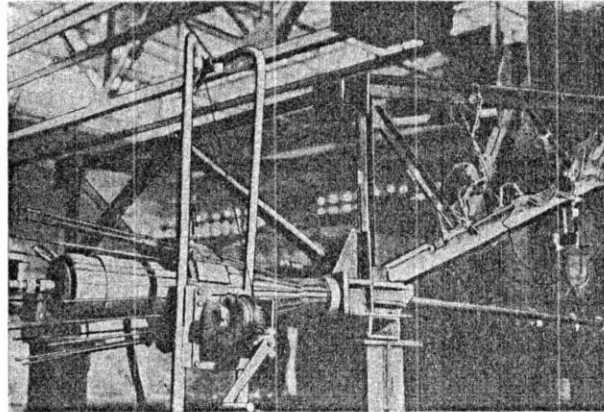
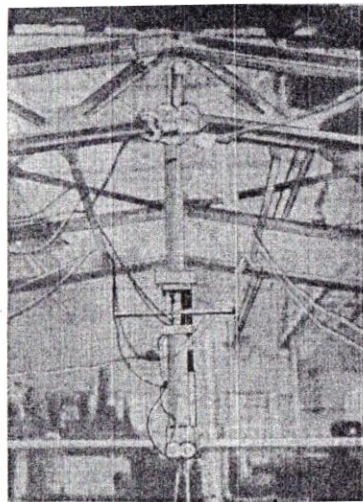

**Fig.2.20. Tensioning truss tendons**

Multi-stage pre-stressing used in the tests of most of the experimental trusses has proved to be very effective and practically feasible.

Multi-stage pre-stressing was most comprehensively studied on the arch-type  $\Phi M2$  truss with a tendon and auxiliary strut connecting the tendon to the bottom chord joint at mid-span. A tubular tendon was tensioned first with the aid of a double-action jack, then a barrel with plug was driven into the anchor (Fig.2.20). Load was applied after this, and the second and third stage pre-stresses were provided with the aid of a helical coupling with double thread (Fig.2.21) inserted into the auxiliary strut of the truss. When the coupling was unscrewed, the strut increased in length and provided a thrust between the tendon and the truss, the tendon being bent slightly and additionally stressed in tension. The truss was loaded by placing cast-iron pigs on a platform. Pre-stressing and loading were affected in three steps (cycles).





**Fig.2.21. Middle strut of  $\Phi$ M2 truss with a tensioning device**

Figures 2.22 and 2.23 show a reduction in the values of deflections and forces in the bars of the top and bottom chords of truss  $\Phi$ M2 as a result of multi-stage pre-stressing. The experimental data agree well with the calculations. Deflections at the last loading stage are by 15% less than their 'calculated values (see Fig.2.22). Agreement of values of test tensionings with their calculated values in the top chord which governs the load-carrying capacity of the truss is better than that in the bottom chord (see Fig.2.23). The largest difference between experimental and calculated data is that on the second stage pre-stressing. Obviously, the particularities of pre-stressing, created by the lengthening of the middle strut, are but partly allowed for in the above design pattern [54], [56].

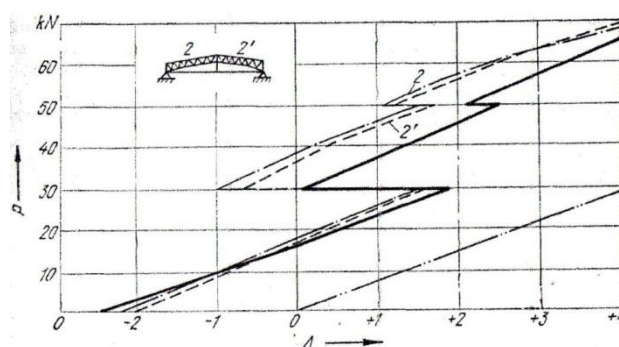
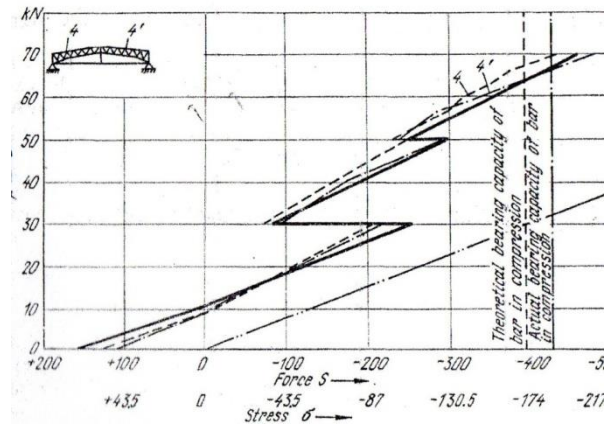

**Fig.2.22. Vertical displacements of truss**

calculated values; — · — · — experimental values; — · — · — calculated values out pre-stressing: 2— assembly of left-hand half of the truss; 2' — assembly of the right-hand half of the truss



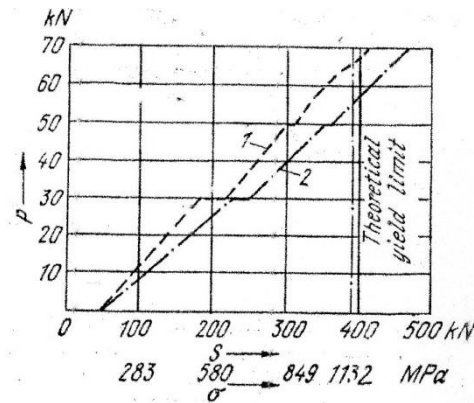



**Fig.2.23. Increment of forces (stresses) in the top chord of truss**

calculated values; — · — experimental values; calculated values without pre-stressing;

4— bar of the left-hand half of the truss; 4'— bar of the right-hand half of the truss

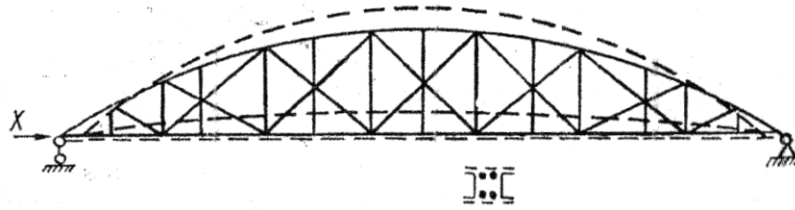

**Fig.2.24. Tendon behaviour as it is tensioned and the truss is loaded**

1—experimental; 2—calculated

Actual forces in the tendon due to loading of the truss are smaller than their calculated values (Fig.2.24). This may be explained by some yielding of the tendon in the anchoring because of a poor care taken when driving the plug home. At the end of tests, the tendon was stretched 10 to 12 mm out of the barrel. Allowance for the yielding of the tendon and the rigidity of the truss assemblies in the design pattern' has greatly narrowed the gap between the test and the calculated data.



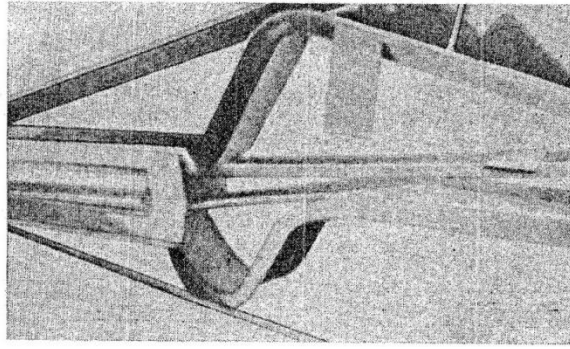

**Fig2.25. Deformation of the truss as a tendon is tensioned**

Comparison of the behaviour of the tendon (see Fig.2.24) with that of the chords – (see Fig.2.23) or the truss deflection (see Fig.2.22) readily shows that a relatively small tensioning of the tendon ( $X \approx 25$  kN, second tensioning) greatly minimizes the force in the top chord (about 180 kN) and the deflection. The self- stress in the tendon is much higher than the total pre-stressing forces. Truss  $\Phi M2$  resisted a load 16% greater than the ultimate calculated value, a fact which evidences of a substantial margin of load-carrying capacity of the pattern considered.

Useful data were obtained in test tensioning of the bottom chord tendon of a hangar roof truss. The entire truss lost the shape as the bottom chord was tensioned (Fig.2.25). A greater part of the Wire rope tensioning force was transmitted to the top chord with the effect that the bottom chord was compressed by a lesser force. These occurrences are, probably, specific to the given pattern of truss. Because of a considerable flexure of the truss bottom chord the tendon branches bore upon the diaphragms and planks which braced together the bottom chord channels, and this gave rise to large friction forces at the points of contact. When the tendons were tensioned by jacks at one side of the truss, the loss to friction was substantial and the tensile force along the tendon was non-uniform. In one of the trusses, the connecting plank was torn off during the tensioning of the tendon, and the bottom chord lost stability (Fig.2.26). In other trusses, the tendons were tensioned until the bottom and the top chords came in contact in the bearing assembly; in the process, the top chord did not take up the tensioning force, and the tendon was loaded by the full calculated value of the pre-stressing force and did not curve out of the truss plane [9], [11].





**Fig.2.26. Deformation of a pre-stressed truss chord in the course of tensioning the tendon**

In case of reliable direct measurement of the pre-stressing force by means of pressure gauges on jacks, for measurement of deflections or stresses in a structure by instruments, etc., the values of factors  $n$  in the calculation of a structure are assumed equal to unity [13].

The overload factor  $n_1 = 1.1$  is taken account of in the two cases below:

(a) when checking the structure during pre-stressing, the factor then being introduced in all the calculated values of cross sections and bars;

(b) when checking the structure during external loading, the factor then being introduced in the values of members and cross-sections in which the external load stresses are of a like sign with that of the stresses due to pre-stressing or in which the pre-stresses are greater in value and opposite in sign to the stresses due to external load.

The underload factor  $n_2 = 0.9$  is introduced when checking the structure in the course of loading by an external load, in the values of all the cross-sections and bars in which stresses from the external load are greater in value and opposite in sign to the pre-stressing force values.

The overload and under load factors should be introduced when calculating beam and frame structures, trusses and similar constructions. When calculating combined members in tension or compression for service loads, the factors may be omitted, as small deviations in the tendon pre-stress value have no substantial effect upon the bearing



capacity of such members, but merely cause a negligible re-distribution of efforts between the bar and the tendon. This has been borne out by tests on members in tension.

When checking a bar for buckling in the course of pre-stressing, the pre-stress should be assumed with an overload factor of  $n_1 = 1.1$ .

## **2.5. Conclusion**

Placement of a tendon along the bottom chord converts the truss into a statically indeterminate system. Therefore, single-span trusses with a single tendon should be calculated as once statically indeterminate systems. The economy of material in these trusses amounts to about 10 to 12%.

A large economy of metal is due to the fact that stresses of the sign opposite to that from the load are produced in the bottom (compressive) and in the top (tensile) chords when tendons are tensioned.

The shortcoming of designs with built-out tendons lies in greater dimensions of trusses which are sometimes inadmissible.

Multi-stage pre-stressing of trusses is particularly advantageous, as the trusses often admit of no considerable single-step pre-stress because of a great flexibility of bars compressed in the course of pre-stressing.

Multi-stage pre-stressing used in the tests of most of the experimental trusses has proved to be very effective and practically feasible.

Multi-stage pre-stressing was most comprehensively studied on the arch-type  $\Phi M2$  truss with a tendon and auxiliary strut connecting the tendon to the bottom chord joint at mid-span.

In the work the calculation of roof truss prestressed by tendon is presented. The main purpose of pre-stressing is that the structure is pre-created stress-strain state, which is



inverse in sign to what will take place during operation of the structure. Therefore, when the load is applied, the forces that were created in the process of pre-stressing are first overcome, and only then at the subsequent load (at 25 operations) there are inverse signs of force, in the process of growth of which comes one of the limit states of the structure.

Pre-stressing allows to apply concretes of the increased durability and accordingly to reduce own weight of designs.



**CHAPTER 3**  
**ARCHITECTURAL PART**



### 3.1. Volume-planning decision

During working on diploma work, I have designed one-story industrial building that has one perpendicular span and three parallel spans. One perpendicular span – 24 m in axis “A-C”, “11-12” has height 15.6, column spacing  $b=6.0$  m and is equipped by overhead track hoist  $Q=50$  t, one parallel span – 30 m “A-B”, “1-10”, and one parallel span – 36 m in axis “B-C”, “1-10” have height 15.6, column spacing  $b=12.0$  m, and are equipped by overhead track crane  $Q=50/20$  t.

Between axis 10 and 11 was designed settlement joint, with insert 350 mm. This joint was designed because of differences in height and crane capacity.

Crane landing for access to the crane cabin of the overhead track crane was designed second column along axis “D”.



**CHAPTER 4**  
**STRUCTURAL PART**





## **4.1. Characteristics of the industrial building**

### 1. Foundation

In industrial buildings usually are used isolated footings. These are intended to support a single column, pier or other concentrated load. Isolated footings may be cast-in-site or assembled from prefabricated elements. They consist of reinforced concrete pad slab and socket type pedestal when used to support the reinforced concrete column.

The twin columns of temperature joint are supported by a common footing, but at settlement joint the columns are arranged on separate footings.

Isolated footings give support to the foundation beams of precast concrete to avoid deformation due to soil expansion at sub-zero temperatures the foundation beams are laid on a cushion of sand or slag 50-60 cm thick.

### 2. Foundation beams

Foundation beams are intended to carry the panels. The foundation beams have nominal dimensions for length 6 and 12 m, as column spacing and the actual dimensions depending on the cross-sectional dimensions of socket type pedestal. The concrete supports under foundation beam are connected near socket type pedestal and they have dimensions in plan 300x600mm.

The top surfaces of foundation beams are situated on level -0,030 and on this level design a damp course that consists of 2 layers of bituminous felt bounded with bituminous mastic.

### 3. Columns

In mass construction columns of one-storey industrial building are usually assembled from steel elements. The columns of a selection are subjected to vertical loads due to the roof structures, crane beams and grades and to horizontal loads due to breaking forces imposed by the cranes. This combination of loads makes the columns work eccentrically compression. The columns of a skeleton construction build may be of a



single piece, of the rectangular in cross-section or of the open-work piece. They may be classed as outer or intermediate according to their location between the walls.

Columns intended to support overhead traveling cranes are consistent of two parts, namely a top portion (above crane beams) carrying the load-bearing elements of the roof and the bottom portion (below the crane beams) transmitting the load from the roof and crane beams to the footing. The crane beams rest on cantilevers provided in the columns. The size of column's cross-section depends on the building's height and span in the buildings designed for the overhead traveling cranes. It's also markedly affected by the crane lifting column. Two-pieces open work columns are employed in buildings over 13.2 m high, equipped with overhead traveling cranes having a load capacity 10-50 tones.

The open space between the side members can be used to pass the various engineering services. The width of the bottom portion is chosen such that the center lines of the crane beams coincide with the center of the side members.

The undercrane part of column consists of two pieces that are combined with lattice.

The column can lose their carrying capacity as lose of stability separate central compressed piece and as lose of stability eccentrically compressed undercrane shaft.

For columns pieces use section steel I-beam type B in accord with ГOCT 26020-83.

For transmitting efforts those are induced in the top part of the column and crane beam design traverse with height 0.5-0.8 from the width of the undercrane column's part. In open web column traverse is worked as beam-wall of I-beam cross-section.

Universal decision of such connection uses the composed welded traverse and its vertical sheet have milled surface.

When width of undercrane part of open web column equals or more than 1m use as rule separate base.

The columns consist of two parts namely top portion (above crane beam), carrying load-bearing elements of the roof, and bottom portion (below crane beam) transmitting the



load from the roof and crane beams to the foundation. The crane beams rest on cantilevers provided in the columns. The columns have cast-in parts for connecting with wall panels, vertical steel braces and roof beams or trusses. The second column at the beginning of the building is equipped with landing for overhead traveling crane.

Framework columns have dimensions in plan 300x300 mm and step 6 m along the end of the building.

#### 4. Crane beams

The height of steel crane beam equals 1000 mm. They have I-section with width of top flange 650 mm. Along the length crane beams have openings diameter 20mm made from pipes for connecting rail track (CR-130).

#### 6. Roof trusses

The standard spans of roof trusses are 12 and 18 m. In ridge roofs the top cord of the beams may be constant slope, trapezoidal or curve. The beams used in shear roofs have parallel cords. Roof beams are available for base and column spacing 6 and 12 m. In the mid span the beam's height is taken as  $1/10..1/15 L$  (L-span) and the standard height of the support equals 800 or 900mm. The width of the bottom flange is taken 250-300mm (depending on snow load and column spacing). All types of beams have steel parts embedded in their top cord for connecting to the roof slabs.

#### 8. Corrugated steel sheets H60-845-07

Dimensions. Usually 2 main parameters are determined: working and full width. For professional sheet H60, these dimensions are different. Working width is 845 mm, total 902 mm. the length depends on the wishes of the customer, but not exceed 12 m.

The material of manufacture is structural carbo steel of ordinary quality, grades CT1:3. It is used to cover roofs on buildings for various purposes, profile height 60 mm, sheet thickness excluding zinc coating 0.7 mm. profile sheet (corrugated board) galvanized H60-845-0.7 can have a zinc coating class of 60 g/m<sup>2</sup>, according to one sample, the standard allows a zinc coating mass of at least 51 g/m<sup>2</sup>, the average coating thickness of



three samples is 4.0 microns, it allows the presence of one sample with a coating thickness of 3.8  $\mu\text{m}$ .

### 7. Wall panels

The walls of industrial building may be built of masonry units (including large blocks, large panels and various light-weight materials), these are used to the walls of unheated building. In industrial buildings the design temperature is lower and therefore wall panels are designed thinner with comparison to civil buildings. The height of standard wall panel for industrial building is assumed 1200 and 1800 mm and additional height for parapet and cornice panels is 900 and 1500 mm. Horizontal joint of wall panel in upper part of one-storey industrial building is designed on 600 mm lower than level of supporting load-bearing structures of roof on columns. The length of wall panel is multiple 600 mm and equals 1200; 1800; 3000; 3600; 6000 and 12000 mm. The length depends on spacing of the columns and dimensions of window openings. For heated building is designed one and three layer wall panel.

### 8. Monitors

A monitor is a raised section of a roof, usually straddling a ridge, which has openings, louvers, or windows along the sides to admit light, air or both. Monitors may be installed along or across the building, although transverse constructions are seldom used now because of complexity and service inconveniences.

Monitors consist of steel or wood frames, which give support to windows, longitudinal walls, end-face walls, roof structures. Monitors are made 6 and 12 m wide, the former being used for 12- and 18- m span , and the latter, for 24- and 30-, 36-m spans. Steel monitors are welded or bolted to steel or reinforced concrete bearing roof members. Lateral bracing is provided between their frames for spatial rigidity.

### **Technical-economical part**

1. Area of structure = 2981.37  $\text{m}^2$

2. Building volume = 36502.884  $\text{m}^3$



## Rating combinations of load

The main combinations of load that we use in course project in accord with ДБН “Load and influences”.

- 1) Dead load+1\*temporary load;
- 2) Dead load+0.9\*(some temporary loads).

Table 4.1

| №                     | Loads, combinations  |                  | $\psi$ | Cross-section 1-1 |          | Cross-section 2-2 |          | Cross-section 3-3 |          |             |
|-----------------------|----------------------|------------------|--------|-------------------|----------|-------------------|----------|-------------------|----------|-------------|
|                       |                      |                  |        | $M$               | $N$      | $M$               | $N$      | $M$               | $N$      | $Q$         |
| 1                     | Dead                 |                  |        | -27.12            | -278.68  | +56.49            | -278.68  | +70.44            | -372.36  | -3.51       |
| 2                     | Snow                 |                  |        | -53.87            | -290.16  | +33.18            | -290.16  | +43.272           | -290.16  | -0.88       |
| 3                     | $F_{\max}$ left      |                  |        | +108.93           | 0        | -176.91           | -635.21  | +87.246           | -635.21  | -23.03      |
| 4                     | $F_{\min}$ right     |                  |        | +108.93           | 0        | +33.78            | -166.99  | +297.94           | -166.99  | -23.03      |
| 5                     | $\pm H_{\max}$ left  |                  |        | $\pm 53.4$        | 0        | $\pm 53.4$        | 0        | $\pm 699.048$     | 0        | $\pm 56.29$ |
| 6                     | $\pm H_{\min}$ right |                  |        | $\pm 53.4$        | 0        | $\pm 53.4$        | 0        | $\pm 252.41$      | 0        | $\pm 17.35$ |
| 7                     | Left wind            |                  |        | -75.02            | 0        | -75.02            | 0        | -429.73           | 0        | -41.592     |
| 8                     | Right wind           |                  |        | +81.41            | 0        | +81.41            | 0        | +408.89           | 0        | +36.58      |
| The main combinations | +                    | $M_{\max}$       | №      | 1+3+5             |          | 1+8               |          | 1+4+5             |          |             |
|                       |                      |                  | 1      | +135.21           | -278.68  | +137.9            | -278.68  | +1067.428         | -539.35  |             |
|                       |                      | $N_{\text{cor}}$ | №      | 1+0.9(3+5+8)      |          | 1+0.9(2+4+6+8)    |          | 1+0.9(2+4+5+8)    |          |             |
|                       |                      |                  | 0.9    | +192.246          | -278.68  | +238.083          | -690.12  | +1006.674         | -783.795 |             |
|                       | -                    | $M_{\max}$       | №      | 1+7               |          | 1+3+5             |          | 1+7               |          |             |
|                       |                      |                  | 1      | -102.14           | -278.68  | -173.82           | -913.89  | -359.29           | -372.36  |             |
|                       |                      | $N_{\text{cor}}$ | №      | 1+0.9(2+7)        |          | 1+0.9(3+5+7)      |          | 1+0.9*7           |          |             |
|                       |                      |                  | 0.9    | -143.121          | -539.824 | -218.31           | -1111.51 | -316.317          | -372.36  |             |
|                       |                      | $N_{\max}$       | №      | 1+3+5             |          | 1+2               |          | 1+3+5             |          |             |
|                       |                      |                  | 1      | +135.21           | -278.68  | +89.67            | -568.84  | +856.734          | -1007.57 |             |



|            |  |       |     |  |          |                |          |  |           |  |  |                |          |
|------------|--|-------|-----|--|----------|----------------|----------|--|-----------|--|--|----------------|----------|
|            |  | $N_0$ |     | 1+0.9(2+3+5+8)   |          | 1+0.9(2+4+6+8) |          | 1+0.9(2+3+5+8)   |           |  |  |                |          |
|            |  |       | 0.9 | +143.763   | -539.824 | +238.083       | -690.12  | +1185.05   | -1205.193 |  |  |                |          |
| $N_{max}$  |  | $N_0$ |     | 1+2  |          | 1+3            |          | 1+7  |           |  |  |                |          |
|            |  |       | 1   | -80.99   | -568.84  | -120.42        | -913.89  | -359.29  | -372.36   |  |  |                |          |
| $-M_{cor}$ |  | $N_0$ |     | 1+0.9(2+7)   |          | 1+0.9(2+3+5+7) |          | 1+0.9(7+3+5)   |           |  |  |                |          |
|            |  |       | 0.9 | -143.12  | -539.824 | -188.445       | -1111.51 | -866.94  | -944.05   |  |  |                |          |
| $N_{min}$  |  | $N_0$ |     | Forces M and N of dead load are taken into account with coefficient 0.9/1.1=0.82 |          |                |          | 0.82(1+8)  |           |  |  |                |          |
|            |  |       | 1   |  |          |                |          | +393.051   | -305.34   |  |  |                |          |
| $-M_{cor}$ |  | $N_0$ |     |  |          |                |          | Forces M and N of dead load are taken into account with coefficient 0.9/1.1=0.82 |           |  |  | 0.82(1+7)      |          |
|            |  |       | 1   |  |          |                |          |  |           |  |  | -294.62        | -305.34  |
| $Q_{max}$  |  | $N_0$ |     |  |          |                |          |  |           |  |  | 1+0.9(2+3+5+7) |          |
|            |  |       | 0.9 |  |          |                |          |  |           |  |  |                | -113.123 |

## 4.2. Calculation and design the open-web left column of the one-storeyed industrial buildings frame

### 4.2.1. Calculation of above crane part of the column

Calculation of the column is provided in plane of bending moment acting and out of the plane.

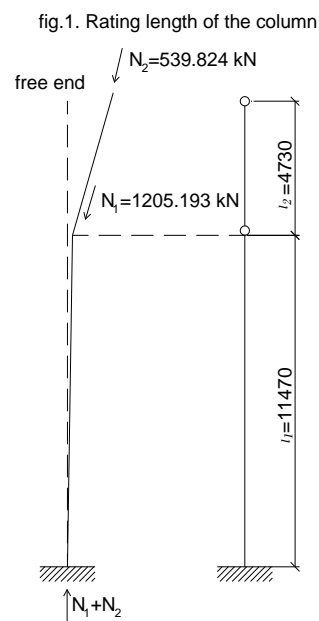

Rating length of the column in plane of the frame:  $l_{ef1,x}, l_{ef2,x}$ , coefficient  $\mu$  depends on fastening end of the column. Assume:

- free end (if column connecting with frame is hinged);
- fastened from turn (if columns connecting with frame is rigid).

Out of the plane: assume hinged fastening.

If ratio geometrical length:

$$\frac{l_2}{l_1} \leq 0.3;$$

$$\beta = \frac{N_1}{N_2} \geq 3;$$

$$N_1 = -1205.193 \text{ kN};$$

$$N_2 = -539.824 \text{ kN}.$$

$\mu$  may be found from table 4.2:

Table 4.2

| Condition of fastening for top end of the column | Coefficient $\mu$                   |                               |         |
|--|-------------------------------------|-------------------------------|---------|
|  | Bottom end $\mu_1$ in $\frac{1}{n}$ |                               | Top end |
|  | $0.3 > \frac{1}{n} \geq 0.1$        | $0.1 > \frac{1}{n} \geq 0.05$ |         |
| Free   | 2.5                                 | 3.0                           | 3.0     |
| Fastening from turn                              | 2.0                                 | 2.0                           | 3.0     |

Rating length:

In plane:

$$\beta = \frac{1205.193}{539.824} = 2.23 < 3$$

$$\frac{1}{n} = \frac{1}{7.6} = 0.13$$

$$\mu_1 = 2.5$$

$$\mu_2 = 3.0$$



$$l_{ef2} = \mu_2 \cdot l_2 = 3.0 \cdot 4.73 = 14.19 \text{ m}$$

$$l_{ef1} = \mu_1 \cdot l_1 = 2.5 \cdot 11.47 = 28.68 \text{ m}$$

Out of the plane:

- for above crane part of the column:

$$l_{ef2,y2} = l_2 - h_{cr.b} = 4.73 - 1.0 = 3.73 \text{ m}$$

- for undercrane part:

$$l_{ef1,y1} = l_1 = 11.47 \text{ m}$$

Assume for above crane part of the column I-beam cross-section height equals 500mm. Rating efforts for cross-section 1-1 are determined in accord with rating combination of efforts assume:

$$N_{\max} = 539.824 \text{ kN}$$

$$+ M_{cor} = 143.763 \text{ kN} \cdot \text{m}$$

Radius of inertia of this cross-section:

$$i_x = 0.42h = 0.42 \cdot 50 = 21.0 \text{ cm}$$

$$\rho_x = \frac{W_x}{A} = 0.35h = 0.35 \cdot 50 = 17.5 \text{ cm}$$

Conditional flexibility:

$$\lambda_x = \lambda_x \sqrt{\frac{R_y}{E}} = \frac{l_{ef2,x}}{i_x} \cdot \sqrt{\frac{R_y}{E}} = \frac{1419}{21} \cdot \sqrt{\frac{240}{2.06 \cdot 10^5}} = 2.31$$

$$C245 \quad R_y = 240 \text{ MPa}$$

Relative eccentricity  $m_x$ :

$$\rho = \frac{W_x}{A}$$





$$m_x = \frac{e \cdot 1}{\rho} = \frac{M \cdot 1}{N \cdot \rho} = \frac{14376 \cdot 1 \cdot 1}{539.824 \cdot 17.5} = 1.52$$

if  $0 < \bar{\lambda} \leq 5$

$$\frac{A_f}{A_w} = 0.5; \quad \eta = (1.75 - 0.1m_x) - 0.02(5 - m_x)\bar{\lambda}_x$$

$$\eta = (1.75 - 0.1 \cdot 1.52) - 0.02 \cdot (5 - 1.52) \cdot 2.31 = 1.44$$

$$m_{ef} = \eta \cdot m_x = 1.44 \cdot 1.52 = 2.19 < 20$$

$$\varphi_e = 0.346$$

where  $\varphi_e$  – coefficient available from table Ж.3 buckling factor for eccentricity compressed elements;  $\eta$  – coefficient of influence the shape of cross-section, available from table Ж.2;  $m_x$  – relative eccentricity, that is calculated by the formula:

$$m_x = \frac{e \cdot A}{W_x}, \quad e = \frac{M}{N}$$

where  $A$  – area of cross-section;  $W_x$  – section moment for the most compressed fiber (table Ж.2 the 5<sup>th</sup> type of cross-section).

Necessary area of cross-section:

$$A_{nec} = \frac{N}{\varphi_e \cdot R_y \cdot \gamma_c} = \frac{539.824}{0.346 \cdot 24 \cdot 1} = 65.01 \text{ cm}^2$$

$$R_y = 240 \text{ MPa} = 24 \text{ kN/cm}^2$$

Assume thickness of the flanges equals 10mm.

For providing local stability of web:

if  $m_x = 1.52 > 1$  and  $\bar{\lambda}_x = 2.31 > 2.0$  (table 10.3)

$$\bar{\lambda}_{uw} = 1.20 + 0.35\bar{\lambda}_x = 1.20 + 0.35 \cdot 2.31 = 2.01$$

where  $\bar{\lambda}_{uw}$  – conditional ultimate flexibility of web.

$$\min t_w = \frac{h_w}{\bar{\lambda}_{uw}} \cdot \sqrt{\frac{R_y}{E}} = \frac{46}{2.01} \cdot \sqrt{\frac{240}{2.06 \cdot 10^5}} = 0.78 \text{ cm}$$



Assume  $t_w = 8 \text{ cm}$

$$A_w = h_w \cdot t_w = 46 \cdot 0.8 = 36.8 \text{ cm}^2$$

$$\frac{A_f}{A_w} = 0.5; \quad A_f = 0.5 \cdot (A_{nec} - A_w) = 0.5 \cdot (65.01 - 36.8) = 14.11 \text{ cm}^2$$

For providing local stability of flange the ratio:

$$\frac{b_f - t_w}{2t_f} \leq (0.36 + 0.1\bar{\lambda}_x) \cdot \sqrt{\frac{E}{R_y}}, \quad A_f = 2b_f t_f$$

$$(0.36 + 0.1 \cdot 2.31) \cdot \sqrt{\frac{2.06 \cdot 10^5}{240}} = 17.31$$

$$t_f = \sqrt{\frac{A_f}{2 \cdot 17.31}} = \sqrt{\frac{14.11}{2 \cdot 17.31}} = 0.64 \text{ cm}$$

For web – 460x8 mm

For flange – 240x10 mm

fig.2. Cross-section of above-crane part of the column

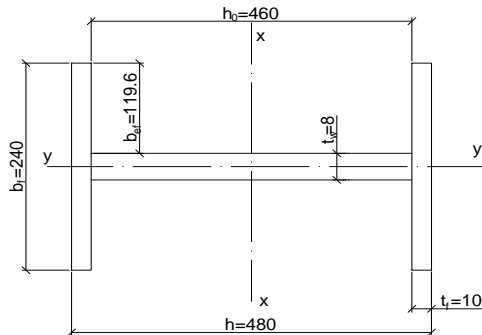

$$A = A_w + 2A_f = 0.8 \cdot 46 + 2 \cdot 24 \cdot 1 = 84.8 \text{ cm}^2$$

$$I_{x-x} = \frac{t_w \cdot h_w^3}{12} + 2 \cdot b_f \cdot t_f \cdot \left( \frac{h_w + t_f}{2} \right)^2 = \frac{0.8 \cdot 46^3}{12} + 2 \cdot 24 \cdot 1 \cdot \left( \frac{46 + 1}{2} \right)^2 = 32997.07 \text{ cm}^4$$

$$I_{y-y} = 2 \cdot \frac{t_f \cdot b_f^3}{12} = 2 \cdot \frac{1 \cdot 24^3}{12} = 2304 \text{ cm}^4$$

$$W_x = \frac{2 \cdot I_x}{h} = \frac{2 \cdot 32997.07}{48} = 1374.88 \text{ cm}^3$$

$$i_x = \sqrt{\frac{I_x}{A}} = \sqrt{\frac{32997.07}{84.8}} = 19.73 \text{ cm}$$



$$i_y = \sqrt{\frac{I_y}{A}} = \sqrt{\frac{2304}{84.8}} = 5.21 \text{ cm}$$

$$\bar{\lambda}_x = \frac{1419}{19.73} \cdot \sqrt{\frac{240}{2.06 \cdot 10^5}} = 2.45$$

$$m_x = \frac{14376.3 \cdot 84.8}{539.824 \cdot 1374.88} = 1.64$$

$$\eta = (1.90 - 0.1 \cdot m_x) - 0.02 \cdot (6 - m_x) \cdot \bar{\lambda}_x = (1.90 - 0.1 \cdot 1.64) - 0.02 \cdot (6 - 1.64) \cdot 2.45 = 1.52$$

$$m_{ef} = 1.64 \cdot 1.52 = 2.49 < 2$$

$$\varphi_e = 0.361$$

$$\bar{\lambda}_{uw} = 1.20 + 0.35 \cdot 2.45 = 2.058$$

### Checks up:

#### 1) Stability in plane:

$$\frac{N}{A \cdot \varphi_e} \leq R_y \gamma_c$$

$$\frac{539.824}{84.8 \cdot 0.361} = 17.63 \text{ kN/sm}^2 = 176.3 \text{ MPa} < 240 \cdot 1 = 240 \text{ MPa}$$

Conclusion: the stability in plane is provided.

#### 2) Stability out of the plane:

$$\lambda_y = \frac{l_{ef,y2}}{i_y} = \frac{373}{5.21} = 71.59$$

$$\bar{\lambda}_y = \lambda_y \sqrt{\frac{R_y}{E}} = 71.59 \cdot \sqrt{\frac{240}{2.06 \cdot 10^5}} = 2.44$$

$$\varphi_y = 0.752$$

$$M_x = 33.825 \text{ kN} \cdot \text{m}$$

$$m_x = \frac{M_x \cdot A}{N \cdot W_x} = \frac{33.825 \cdot 84.8}{539.824 \cdot 1374.88} = 0.39$$

$$\text{if } m_x \leq 1 \quad \alpha = 0.7$$

$$\lambda_y = 71.59 < \lambda_c = 3.14 \cdot \sqrt{\frac{E}{R_y}} = 92 \Rightarrow \beta = 1$$

$$C = \frac{\beta}{1 + \alpha \cdot m_x} = \frac{1}{1 + 0.7 \cdot 0.39} = 0.79$$

$$\frac{N}{C \cdot \varphi_y \cdot A} \leq R_y \gamma_c$$



$$\frac{539.824}{0.79 \cdot 0.752 \cdot 84.8} = 10.72 \text{ kN/sm}^2 = 107.2 \text{ MPa} < R_y \gamma_c = 240 \text{ MPa}$$

Conclusion: the stability out of the plane is provided.

3) Local stability of web:

$$\bar{\lambda}_w = \frac{h_w}{t_w} \sqrt{\frac{R_y}{E}} = \frac{46}{0.8} \cdot \sqrt{\frac{240}{2.06 \cdot 10^5}} = 1.96 < \bar{\lambda}_{uw} = 2.047$$

Conclusion: the local stability of web is provided.

#### 4.2.2. Calculation and design the undercrane part of column

fig.1. Design (a) and rating (b) schemes of the column

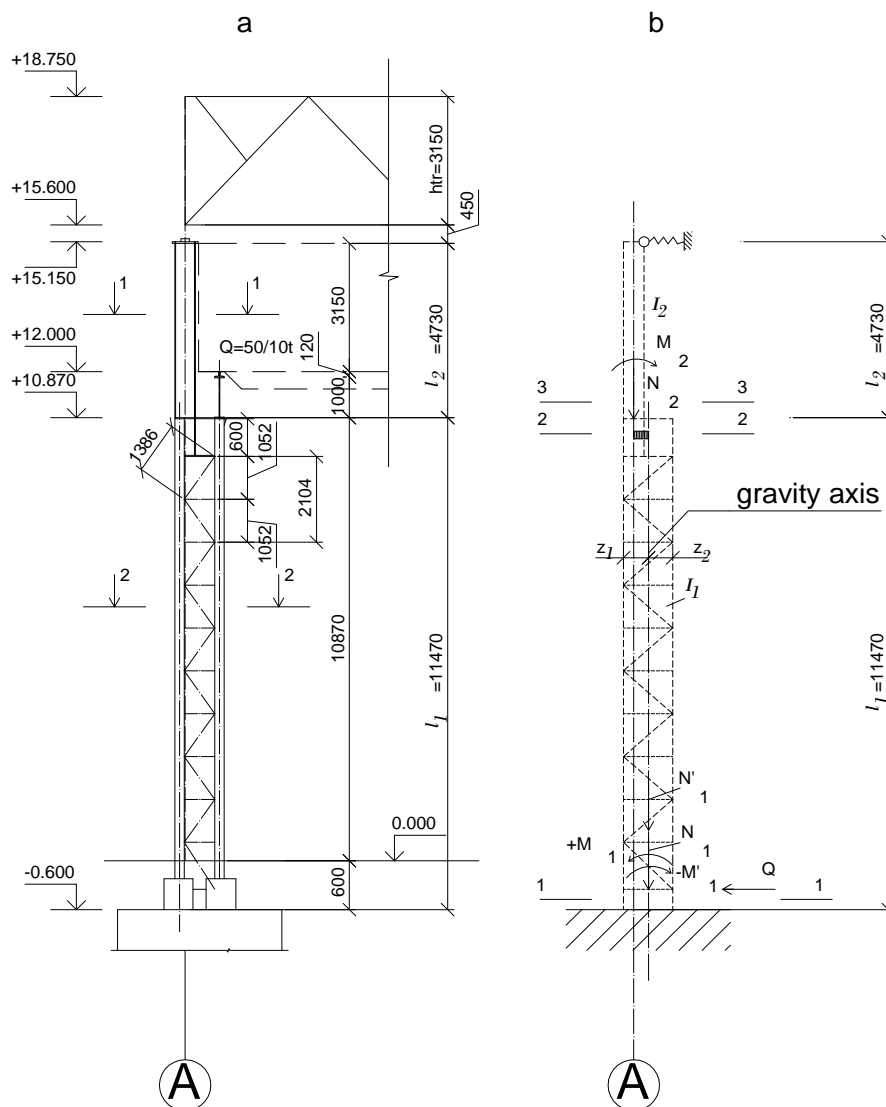
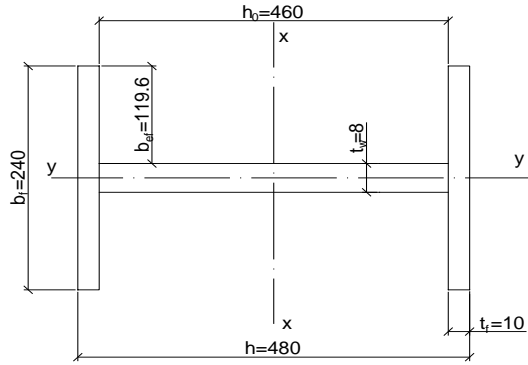
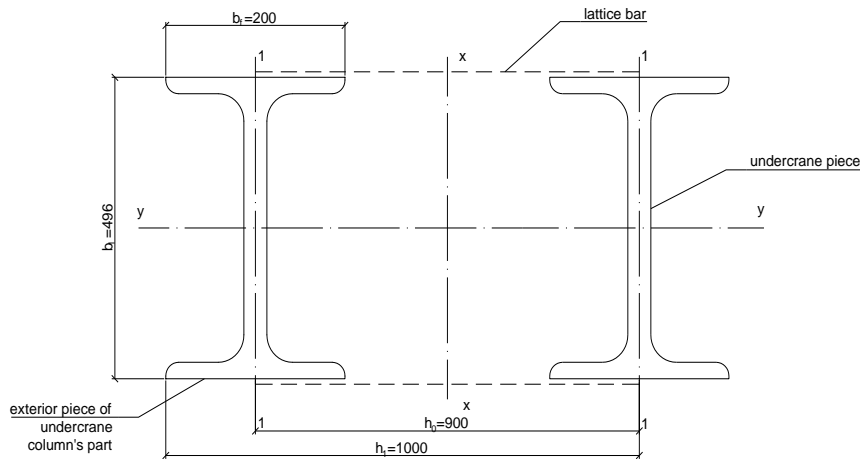

fig.2. Cross-section 1-1 of above-crane part of the column



1) The undercrane part of column consists of two pieces that are combined with lattice. The column can lose their carrying capacity as lose of stability separate central compressed piece and as lose of stability eccentrically compressed undercrane shaft. For columns pieces use section steel I-beam type B in accord with ГOCT 26020-83.

fig.3. Undercrane shaft of the column (cross-section 2-2)



Rating combination of efforts in piece is calculated by the formula:

$$N_p = \frac{N}{2} + \frac{|M|}{h_0}$$

$$h_0 \approx 2e_{cr}$$

Checks up the stability by the formula:

$$\frac{N_p}{\varphi \cdot A_p} \leq R_y \gamma_c,$$

where  $\varphi$  – is the buckling factor in accord with maximum deflection of piece in plane or out of the plane (axis y-y or 1-1).



Necessary area of one piece cross-section may be calculated by the formula:

$$A_p = \frac{N_p}{\varphi \cdot R_y \cdot \gamma_c}, \quad \varphi \approx 0.8$$

Choose the cross-section and check up the stability out of the plane. For this purpose we calculated flexibility:

$$\bar{\lambda}_y = \frac{l_{y1}}{i_y} \cdot \sqrt{\frac{R_y}{E}} \Rightarrow \varphi(\mathcal{K}.1)$$

2) Calculation shaft of the column in accord with axis x-x if  $m_{ef} \leq 20$  we calculate on stability by the formula:

$$\sigma = \frac{N}{\varphi_e \cdot A} \leq R_y \gamma_c$$

$$m = \frac{e \cdot A \cdot y}{I_x}, \quad e = \frac{M}{N}$$

where  $A$  – total area of column cross-section;  $I_x$  – moment of inertia in accord with axis x-x;  $y$  – is distance from the axis to the center of the gravity piece.

$$\varphi_e \Rightarrow \bar{\lambda}_{ef} = \lambda_{ef} \cdot \sqrt{\frac{R_y}{E}}$$

$$\lambda_{ef} = \sqrt{\lambda_x^2 + \frac{\alpha \cdot A_d}{Ad_1}}$$

$$\lambda_x = \frac{l_x}{i_x}$$

$Ad_1$  – its area of cross-section of lattice bar.

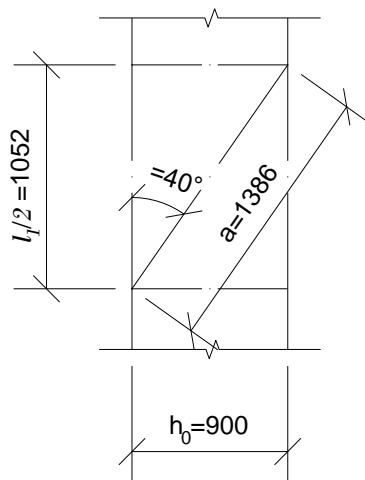

$$\alpha = \frac{10 \cdot a^3}{h_0^2 \cdot 0.5 \cdot l_1}$$

a – length of lattice bar.

Lattice bar is calculated in accord with rating shear force that is assumed in accord with calculations or  $Q_{fic}$ .

$$Q_{fic} = 7.15 \cdot 10^{-6} \left( 2330 - \frac{E}{R_y} \right) \cdot \frac{N}{\varphi}$$

where  $\varphi$  – buckling factor in plane of lattice in term of  $\lambda_{ef}$ .

Choose from table rating combination of efforts maximum values of bending moment with sign “+” and “-”.

Assume:

$$M^+ = 1185.05 \text{ kN} \cdot \text{m}, \quad N = -1205.193 \text{ kN}$$

$$M^- = -866.94 \text{ kN} \cdot \text{m}, \quad N = -944.05 \text{ kN}$$

$$N_{p,ext} = \frac{1205.193}{2} + \frac{1185.05}{1} = 1787.65 \text{ kN}$$

Assume  $h_0 = 1.0 \text{ m}$

$$N_{p,int} = \frac{944.05}{2} + \frac{866.94}{1} = 1338.97 \text{ kN}$$

Assume for further calculation maximum value:

$$N_p = 1787.65 \text{ kN}$$

$$C245 \quad R_y = 240 \text{ MPa} (24 \text{ kN} / \text{cm}^2)$$

$$(t_f = 2.20 \text{ mm})$$

$$\gamma_c = 1.0$$

Necessary area of piece:

if  $\varphi \approx 0.8$

$$A_{p,nec} = \frac{1787.65}{0.8 \cdot 24.0 \cdot 1.0} = 93.12 \text{ cm}^2$$

Assume from catalogue:



50B2

$$A = 102.80 \text{ cm}^2 > A_{p,nec} = 93.12 \text{ cm}^2$$

$$i_y = 20.30 \text{ cm}$$

$$i_{1-1} = 4.27 \text{ cm}$$

$$I_{1-1} = 1873.0 \text{ cm}^4$$

$$l_{ef,y_1} = 11.47 \text{ m}$$

$$\lambda_y = \frac{l_{ef,y_1}}{i_y} = \frac{1147}{20.30} = 56.5$$

$$\bar{\lambda}_y = 56.5 \cdot \sqrt{\frac{240}{2.06 \cdot 10^5}} = 1.93 \Rightarrow \varphi = 0.836 (\mathcal{K}.1)$$

$$h_0 = h_1 - \frac{b_f}{2} = 1000 - \frac{200}{2} = 900 \text{ mm}$$

Lets specify:

$$N_p = \frac{1205.193}{2} + \frac{1185.05}{0.900} = 1919.32 \text{ kN}$$

$$\sigma = \frac{N_p}{\varphi \cdot A_p} = \frac{1919.32}{0.836 \cdot 102.8} = 22.33 \text{ kN/cm}^2 < R_y \gamma_c = 24 \text{ kN/cm}^2$$

Conclusion: the stability is provided.

From condition of stable equilibrium in plane and out of the plane lets determine the distance from joint of lattice.

$$\lambda_{11} = \frac{l_1}{i_{1-1}} = \lambda_y = 56.5 < 80$$

$$l_1 = \lambda_y \cdot i_{1-1} = 56.5 \cdot 4.27 = 241 \text{ cm}$$

Assume  $l_1 = 210.4 \text{ cm}$

$$\lambda_{11} = \frac{210.4}{4.27} = 49.27 < 56.5$$

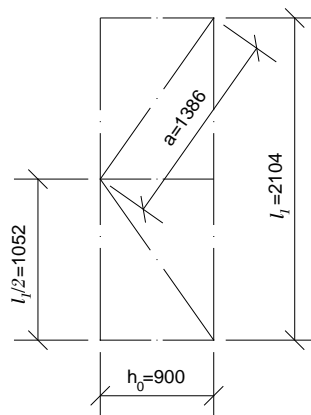



## Calculation the lattice of undercrane column part

$$Q_{\max} = 113.123 \text{ kN}$$

Conditional shear force:

$$Q_{fic} = 7.15 \cdot 10^{-6} \left( 2330 - \frac{2.06 \cdot 10^5}{240} \right) \cdot \frac{1205.193}{0.6} = 21.92 \text{ kN} < Q_{\max}$$

$$\varphi \approx 0.6$$

Because of this choice the cross-section of lattice is determined by  $Q_{\max}$  :

$$a = \sqrt{0.900^2 + 1.052^2} = 1.386 \text{ m}$$

$$\sin \alpha = \frac{h_0}{a} = \frac{0.900}{1.386} = 0.6436 \Rightarrow 40^\circ$$

Effort in lattice:

$$N_l = \frac{Q_{\max}}{2 \sin \alpha} = \frac{113.123}{2 \cdot 0.6436} = 87.88 \text{ kN}$$

Lattice is designed from one equal leg angle.

Assume:

$$\lambda_0 \approx 90 \Rightarrow \bar{\lambda} \Rightarrow \varphi = 0.612 \quad (\gamma_c = 0.75 - \text{for single angle that is fastened by leg})$$

Necessary area of lattice bar:

$$A_{l,nec} = \frac{87.88}{0.612 \cdot 24 \cdot 0.75} = 7.98 \text{ cm}^2$$

Assume:

└ 80x6

$$A = 9.38 \text{ cm}^2 > A_{l,nec} = 7.98 \text{ cm}^2$$

$$i_{\min} = i_{y_0} = 1.58 \text{ cm}$$

$$\lambda_y = \frac{l_{ef,y_1}}{i_y} = \frac{138.6}{1.58} = 87.7$$

$$\bar{\lambda}_y = 87.7 \cdot \sqrt{\frac{240}{2.06 \cdot 10^5}} = 2.99 \Rightarrow \varphi = 0.645 \text{ (Ж.1)}$$

$$\sigma = \frac{N_l}{\varphi \cdot A_l} = \frac{87.88}{0.645 \cdot 9.38} = 14.53 \text{ kN/cm}^2 < R_y \gamma_c = 24 \cdot 0.75 = 18 \text{ kN/cm}^2$$

Conclusion: the stability is provided.



### Checks up the shaft of the column and the first geometrical characteristics:

$$A = 2A_p = 2 \cdot 102.80 = 205.6 \text{ cm}^2$$

$$I_{x-x} = 2 \left[ I_{1-1} + A_p \left( \frac{h_0}{2} \right)^2 \right] = 2 \cdot [1873 + 102.80 \cdot (45)^2] = 420086 \text{ cm}^4$$

$$\lambda_x = \frac{l_{ef,x_1}}{i_x} = \frac{2867.5}{45.2} = 63.44$$

$$i_x = \sqrt{\frac{I_x}{A}} = \sqrt{\frac{420086}{205.6}} = 45.2 \text{ sm}$$

$$\alpha = \frac{10 \cdot a^3}{h_0 \cdot 0.5l_1} = \frac{10 \cdot 1.386^3}{0.900 \cdot 1.052} = 28.12$$

$$\lambda_{ef} = \sqrt{\lambda_x^2 + \alpha \frac{A}{2Ad_l}} = \sqrt{63.44^2 + 28.12 \cdot \frac{205.6}{2 \cdot 9.38}} = 65.82$$

$$\bar{\lambda}_{ef} = \lambda_{ef} \cdot \sqrt{\frac{R_y}{E}} = 65.82 \cdot \sqrt{\frac{240}{2.06 \cdot 10^5}} = 2.25$$

$$\lambda_{11} = 56.5 < \lambda_{ef} = 65.82$$

**Note.** Relative eccentricity is determined when the interior piece is loaded.

$$m = e \cdot \frac{A \cdot y}{I_x} = \frac{118505}{1205.193} \cdot \frac{205.6 \cdot 45}{420086} = 2.17 < 20$$

$$\lambda_{ef} = 2.25 \Rightarrow \varphi_e = 0.365$$

$$\frac{N}{A \cdot \varphi_e} \leq R_y \gamma_c$$

$$\frac{1205.193}{205.6 \cdot 0.365} = 16.06 \text{ kN/sm}^2 < R_y \gamma_c = 24 \text{ kN/sm}^2$$

Conclusion: the stability is provided.

#### 4.2.3. Design and calculation the top and bottom column's part

Assume structural decision of connection that is similar to type decision (see fig.3.9 a – structural decision of connection , b – cross-section of traverse, c – rating scheme of traverse).

For transmitting efforts those are induced in the top part of the column and crane beam design traverse with height 0.5-0.8 from the width of the undercrane column's part. In open web column traverse is worked as beam-wall of I-beam cross-section.



Universal decision of such connection uses the composed welded traverse and its vertical sheet have milled surface. Top horizontal diaphragm (cross-section 1-1) is lower on 200mm for convenience of assembly.

In butt cover plate that is welded to bottom column's part and to I-beams flange upper column's part foresee openings for bolts ( $d=23\text{mm}$ ). The thickness of a butt cover plate is assumed equals the thickness of flange upper column's part. The thickness of plate is assumed in term of maximum vertical crane load  $F_{\max}$  that is induced in crane beam.

Table 4.3

| $F_{\max}, kN$ | Up to 1500 | 1500-2500 | >2500 |
|----------------|------------|-----------|-------|
| $t_{pl}, mm$   | 20         | 25        | 30    |

The thickness of traverse stiffener is bigger in 1.5-2 times than flange upper column's part.

Horizontal elements of traverse its necessary to take with thickness 10mm.

The thickness of traverse web  $t_w$  is determined on condition of pressure under  $F_{\max}$  that is transmitted from bearing stiffener of crane beam through support plate ( $t_{pl}$ ) on milled surface of web.

Necessary thickness of traverse web is calculated by the formula:

$$t_{w,nec} = \frac{1.2F_{\max}}{R_p \cdot z}$$

where 1.2 – coefficient that takes into account non-uniform pressure on traverse because of possible bending of bearing stiffeners;

$R_p$  – design resistance of steel by pressure;

$$R_p = R_n (I.2);$$

$z = b_{o,p} + 2t_{pl}$ ;  $b_{o,p}$  – bearing stiffener of crane beam.

The rating combination of efforts are  $F_1$  and  $F_2$  (cross-section 1-1).

Maximum value  $F_1$  is taken place when:



$$M_1(-)$$

$$N_1(-)$$

But maximum value  $F_2$  is taken place when:

$$M_2(+)$$

$$N_2(-)$$

For most reliability of fastening traverse you should made a cut in web of column.

Formulas for calculation elements of traverse are available in table 3.5 and for calculation welds of traverse in table 3.6.

$$M_1(-) = 143.121 \text{ kN} \cdot \text{m}$$

$$N_1(-) = 539.824 \text{ kN}$$

$$M_2(+) = 143.763 \text{ kN} \cdot \text{m}$$

$$N_2(-) = 539.824 \text{ kN}$$

$$F_{\max} = 635.21 \text{ kN}$$

$$F_1 = \frac{N_1}{2} + \frac{|M_1|}{h_f} = \frac{539.824}{2} + \frac{143.121}{0.47} = 574.42 \text{ kN}$$

$$F_2 = \frac{N_2}{2} + \frac{|M_2|}{h_f} = \frac{539.824}{2} + \frac{143.763}{0.47} = 575.79 \text{ kN}$$

Necessary thickness of traverse web:

$$t_{w,nec} = \frac{1.2F_{\max}}{R_p \cdot z} = \frac{1.2 \cdot 635.21}{22 \cdot 36} = 0.96 \text{ cm}$$

$$t_{pl} = 20 \text{ mm}$$

$$b_{o,p} = 180 \text{ mm}$$

$$z = 180 + 2 \cdot 20 = 220 \text{ mm}$$

$$R_p = 360 \text{ MPa}$$

Assume  $t_{w,tr} = 10 \text{ mm}$ .

Efforts in traverse are calculated by the following formulas:

$$Q_l = \frac{F_1 \cdot l_2}{l_1 + l_2} = \frac{574.42 \cdot 52.5}{90} = 335.08 \text{ kN}$$

$$Q_r = \frac{F_1 \cdot l_1}{l_1 + l_2} + 0.6F_{\max} = \frac{574.42 \cdot 37.5}{90} + 381.63 = 620.47 \text{ kN}$$

$$M_{tr} = (Q_r - 0.6F_{\max}) \cdot l_2 = (620.47 - 381.13) \cdot 0.525 = 125.66 \text{ kN} \cdot \text{m}$$

Geometrical characteristics cross-section of traverse:



Assume height of web 600mm.

$$W' = \frac{t_w \cdot h_w^2}{6} = \frac{1 \cdot 60^2}{6} = 600 \text{ cm}^3$$

$$A' = t_w \cdot h_w = 1 \cdot 60 = 60 \text{ cm}^2$$

Stresses in traverse under bending:

$$\sigma' = \frac{M_{tr} \cdot 1000}{W'} \leq R_y \gamma_c$$

$$\sigma' = \frac{125.66 \cdot 1000}{600} = 209.43 \text{ MPa} < R_y \gamma_c = 240 \text{ MPa}$$

Conclusion: the normal stresses are provided.

$$\tau = \frac{1.5 Q_r \cdot 10}{A'} \leq R_s \gamma_c, \quad R_s = 0.58 R_y$$

$$\tau = \frac{1.5 \cdot 620.47 \cdot 10}{60} = 155.12 \text{ MPa} > R_s \gamma_c = 140 \text{ MPa}$$

Conclusion: the tangential stresses are not provided because of this enlarged.

Assume  $h_{tr} = 680 \text{ mm}$ .

$$A' = 1 \cdot 68 = 68 \text{ cm}^2$$

$$\tau = \frac{1.5 \cdot 620.47 \cdot 10}{68} = 136.87 \text{ MPa} < R_s \gamma_c = 140 \text{ MPa}$$

Conclusion: the tangential stresses are not provided.

Checks up the web undercrane piece of column on shear by lines 1-1.

$$\tau_{und.p} = \frac{(Q_r + 0.6 F_{\max}) \cdot 10}{2 \cdot h_{w,tr} \cdot h_{w1}} = \frac{(620.47 + 381.13) \cdot 10}{2 \cdot 68 \cdot 0.92} = 80.05 \text{ MPa} < R_s \gamma_c = 140 \text{ MPa}$$

Checks up compressed stresses in web undercrane piece of column.

$$\sigma_{und.p} = \frac{(Q_r + 0.6 F_{\max}) \cdot 10}{A_{ef}} \leq R_y \gamma_c$$

$$A_{ef} = z \cdot t_w + 30 t_{w1}^2 = 22 \cdot 1 + 30 \cdot 0.92^2 = 47.392 \text{ cm}^2$$

$$\sigma_{und.p} = \frac{(620.47 + 381.13) \cdot 10}{47.392} = 211.34 \text{ MPa} < R_y \gamma_c = 240 \text{ MPa}$$

Conclusion: the compressed stresses are provided.

$$N_{w1} = -\frac{N_2}{2} - \frac{M_1}{h_f} = -\frac{539.824}{2} - \frac{143.121}{0.47} = -574.42 \text{ kN (compression)}$$



$$N_{w1} = -\frac{N_2}{2} + \frac{M_2}{h_f} = -\frac{539.824}{2} + \frac{143.763}{0.47} = 35.97 \text{ kN (tension)}$$

$$\sigma_w = \frac{N_{w1}}{t_f \cdot b_f} \leq R_y \gamma_c \text{ (compression)}$$

$$\sigma_w = \frac{574.42}{1.24} = 23.93 \text{ kN/cm}^2 < R_y \gamma_c = 24 \text{ kN/cm}^2$$

$$\sigma_w = \frac{N_{w1}}{t_f \cdot b_f} \leq 0.85 R_y \gamma_c \text{ (tension)}$$

$$\sigma_w = \frac{35.97}{1.24} = 1.499 \text{ kN/cm}^2 = 14.99 \text{ MPa} < 0.85 R_y \gamma_c = 204 \text{ MPa}$$

$$N_{w2} = F_2 = 575.79 \text{ kN}$$

Assume for manual welding:

$$R_{wf} = 180 \text{ MPa}$$

$$\beta_f = 0.7; \beta_z = 1.0$$

$$\max k_f = 1.2 t_{\min} = 1.2 \cdot 10 = 12 \text{ mm}$$

$$k_{f_{w2}} = \frac{N_{w2}}{\beta_f \cdot (2 \cdot l + b_f - 3 \text{ cm}) R_{wf}} = \frac{575.79}{0.7 \cdot (2 \cdot 60 + 24 - 3) \cdot 18} = 0.24 \text{ mm}$$

Assume  $k_{f_{w2}} = 7 \text{ mm}$ .

$$k_{f_{w3}} = \frac{Q_r + 0.6 F_{\max}}{4 \beta_f \cdot h_{tr} \cdot R_{wf}} = \frac{620.47 + 381.13}{4 \cdot 0.7 \cdot 68 \cdot 18} = 0.29 \text{ mm}$$

$$t_{tr} = 20 \text{ mm}$$

$$t_{w1} = 9.2 \text{ mm}$$

Assume  $k_{f_{w3}} = 7 \text{ mm}$ .

$$N_{w4} = Q_l = 335.08 \text{ kN}$$

$$k_{f_{w4}} = \frac{N_{w4}}{2 \beta_f \cdot h_{tr} \cdot R_{wf}} = \frac{335.08}{2 \cdot 0.7 \cdot 68 \cdot 18} = 0.2 \text{ mm}$$

Assume  $k_{f_{w4}} = 7 \text{ mm}$ .

$$N_{w5} = F_1 = 574.42 \text{ kN}$$

$$k_{f_{w5}} = \frac{N_{w5}}{4 \beta_f \cdot h_{tr} \cdot R_{wf}} = \frac{574.42}{4 \cdot 0.7 \cdot 68 \cdot 18} = 0.17 \text{ mm}$$

$$t_{tr} = 20 \text{ mm}$$

$$t_{tr,s} = 20 \text{ mm}$$

Assume  $k_{f_{w5}} = 7 \text{ mm}$ .



#### 4.2.4. Design and calculation the base of the column

When width of undercrane part of open web column equals or more than 1m use as rule separate base.

Fig.4.7. Structural scheme of the column

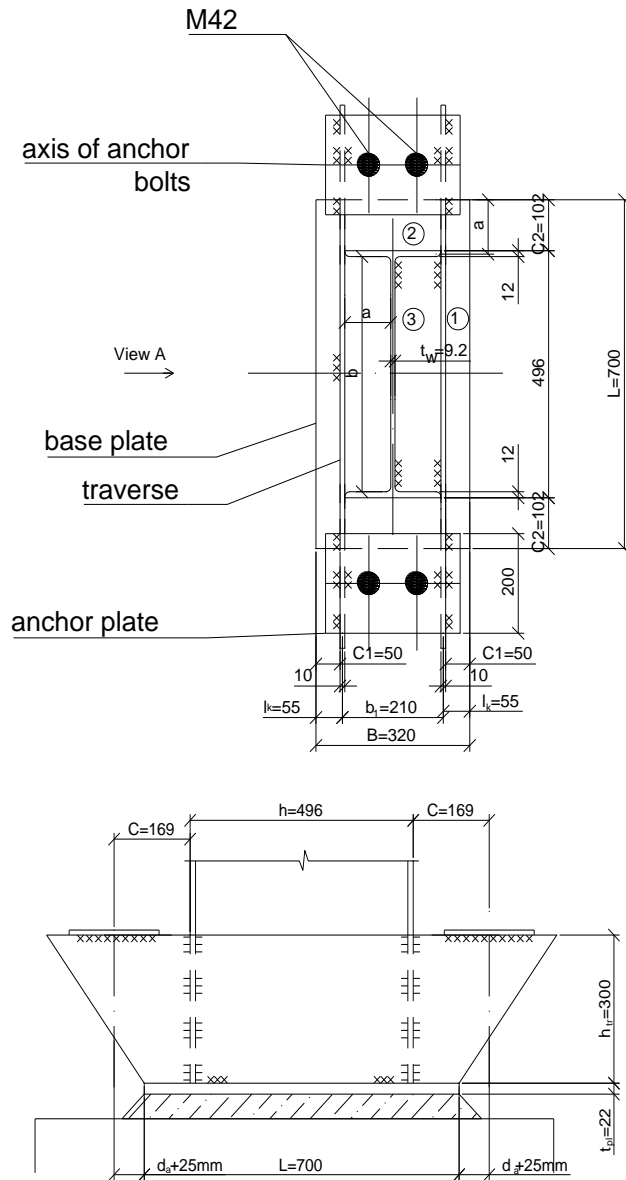

Rating combination of efforts assume like for undercrane part of column, that transmit maximum pressure of foundation concrete. Its necessary to determine:

- 1) dimensions bearing base plate in plane ( $L$  and  $B$ );
- 2) thickness of the plate ( $t_{pl}$ );
- 3) height of the traverse ( $h_{tr}$ ).



Then to assume cross-section dimensions of traverse, check up strength and calculate anchor plates with bolts.

Rating compressed longitudinal force assume:

$$N_b = 1919.32 \text{ kN.}$$

From condition of providing strength of foundation concrete on pressure under column. Lets determine necessary area of the base plate:

$$A_{pl,nec} = \frac{N_b}{f_{ck,loc}},$$

where  $f_{ck,loc} = f_{ck} \cdot \gamma_b$

$$f_{ck} = 7.5 \text{ MPa}$$

where  $f_{ck}$  – design resistance of concrete available from table 3.1 ДБН “Залізобетонні конструкції”.

$$f_{ck,loc} = 7.5 \cdot 1.2 = 9.0 \text{ MPa} = 0.9 \text{ kN/cm}^2,$$

$$A_{pl,nec} = \frac{1919.32}{0.9} = 2132.58 \text{ cm}^2$$

Assume:

$$t_{tr} = 10 \text{ mm}$$

( $t_{tr} \approx t_f$  undercrane piece of column because of this thickness may be enlarge up to 17 mm) The

width of over hang:

$$C_1 = 50 \text{ mm (not less than 40mm).}$$

$$B = b_0 + 2t_{tr} + 2C_1 = 200 + 2 \cdot 10 + 2 \cdot 50 = 320 \text{ mm} = 32.0 \text{ cm}$$

$$\text{Assume } B = 32.0 \text{ cm.}$$

$$L = \frac{A_{pl,nec}}{B} = \frac{2132.58}{32} = 66.64 \text{ cm}$$

$$\text{Assume } L = 70 \text{ cm.}$$





Average value of stresses under foundation plate:

$$\sigma_f = \frac{N_b}{B \cdot L} = \frac{1919.32}{32 \cdot 70} = 0.86 \text{ kN/cm}^2 = 8.6 \text{ MPa}$$

The bearing plate is under bending and for determining its thickness calculate bending moments on parts 1, 2, and 3.

Part №1 (cantilever overhang)

The formulas for calculating parts and bearing plates available from appendix M table M.2:

$$M_1 = \sigma_f \cdot C_1^2 / 2 = 0.86 \cdot 5^2 / 2 = 10.75 \text{ kN} \cdot \text{cm}$$

Part №2

$$M_2 = \alpha \cdot \sigma_f \cdot b_0^2,$$

where  $\alpha$  – available from table M.2 and depend on ratio  $C_2 / b_0$ ,

$$\text{where } C_2 = (L_{pl} - h) / 2 = (70 - 49.6) / 2 = 10.2 \text{ cm}$$

$$\alpha \Rightarrow C_2 / b_0 = \frac{10.2}{20} = 0.51$$

$$\alpha = 0.060$$

$$M_2 = 0.06 \cdot 0.86 \cdot 20^2 = 20.64 \text{ kN} \cdot \text{cm}$$

Part №3 (supported by 4 sides)

$$M_3 = \alpha \cdot \sigma_f \cdot \left( \frac{b_0 - t_w}{2} \right)^2$$

$$\alpha \Rightarrow b / a = 49.6 / 9.54 = 5.2 > 2$$

$$\alpha = 0.125 \text{ (M.2)}$$

$50B2 t_w = 9.2 \text{ mm}$  (in accord with catalogue)

$$M_3 = 0.125 \cdot 0.86 \cdot \left( \frac{20 - 0.92}{2} \right)^2 = 9.78 \text{ kN} \cdot \text{cm}$$

For determination necessary thickness of plate we choose maximum bending moment from part №2:



$$t_{pl} = \sqrt{\frac{6M_{\max}}{R_y \gamma_c}} = \sqrt{\frac{6 \cdot 20.64}{23 \cdot 1.2}} = 2.12 \text{ cm}$$

$\gamma_c$  – in this case equals 1.2 – its coefficient of working condition for bearing plates;

$R_y = 230 \text{ MPa}$  – its for grade of C255 (20...40mm).

Assume  $t_{pl} = 22 \text{ mm}$  from sheet steel 30mm – 2mm for milling.

### Calculation of the traverse

Its necessary to determine: efforts in traverse, height of traverse and check up normal and tangential stresses:

$$l_k = C_1 + 0.5t_{tr} = 50 + 0.5 \cdot 10 = 55 \text{ mm} = 5.5 \text{ cm}$$

$$b_1 = b_0 + t_{tr} = 200 + 10 = 210 \text{ mm} = 21 \text{ cm}$$

$$a = C_2 + 0.5t_f = 102 + 0.5 \cdot 14 = 109 \text{ mm} = 10.9 \text{ cm}$$

Linear evenly distributed load acting on traverse is calculated by the formula:

$$q_{tr} = \sigma_f (l_k + 0.25b_1) = 0.86 \cdot (5.5 + 0.25 \cdot 21) = 9.245 \text{ kN/cm}$$

Concentrated load acting on traverse is calculated by the formula:

$$N_{tr} = q_{tr} \cdot L = 9.245 \cdot 70 = 647.15 \text{ kN}$$

Minimum leg of fillet weld is calculated by the formula (there are two fillet welds for fastening one traverse to the column):

$$k_f = \frac{1}{\beta_f} \sqrt{\frac{N_{tr}}{n \cdot 85 R_{wf} \gamma_{wf} \gamma_c}},$$

$$R_{wf} = 180 \text{ MPa}, \quad \beta_f = 0.9$$

$$k_f = \frac{1}{0.9} \sqrt{\frac{647.15}{2 \cdot 85 \cdot 18 \cdot 1.1}} = 0.51$$

Assume  $k_f = 8 \text{ mm}$  and this leg met the requirements.

$$\min k_f = 5 \text{ mm} (16.1) < k_f = 8 \text{ mm} < \max k_f = 1.2t_{\min} = 12 \text{ mm}$$



$$h_{tr} = l_{w,nec} + 1.0 \text{ cm} = \frac{N_{tr} \cdot 10}{2\beta_f \cdot k_f \cdot R_{wf} \cdot \gamma_c} + 1.0 \text{ cm} \leq 85\beta_f k_f$$

$85\beta_f k_f$  – maximum length of fillet weld.

$$h_{tr} = \frac{647.15 \cdot 10}{2 \cdot 0.9 \cdot 0.8 \cdot 180 \cdot 1.0} + 1 \text{ cm} = 24.97 + 1 \text{ cm} = 25.97 \text{ cm}$$

Assume  $h_{tr} = 26 \text{ cm}$ .

The leg of fillet welds for connecting traverse to the bearing plate assume (without calculations) from the table 16.1.

Rating efforts of separation for calculating anchor bolts we use with maximum bending moment (+) in cross-section 3-3.

$$N_a = \frac{1185.05}{0.9} - \frac{1205.193}{2} = 714.13 \text{ kN}$$

Assume 4 bolts  $N_b = \frac{N_a}{4} = 178.53 \text{ kN}$

$$R_{ba} = 185 \text{ MPa}$$

$$A_{bn} = \frac{N_b}{R_{ba}} = \frac{178.53}{18.5} = 9.65 \text{ cm}^2$$

Assume anchor bolts  $\varnothing 42 \text{ mm}$ .

Rating scheme of traverse:

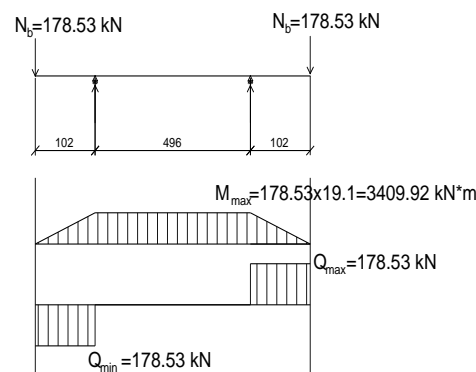

Cross-sectional characteristics of traverse:

$$A_{tr} = 26 \cdot 1 = 26 \text{ cm}^2$$

$$W_{tr} = \frac{1 \cdot 26^2}{6} = 112.67 \text{ cm}^3$$



$$\sigma = \frac{M}{W} \leq R_y \gamma_c$$

$$\sigma = \frac{3409.92}{112.67} = 30.26 \text{ kN/cm}^2 > R_y \gamma_c = 24 \text{ kN/cm}^2$$

Conclusion: the condition is not provided.

Enlarge traverse up to 300x12.

$$A_{tr} = 30 \cdot 1.2 = 36 \text{ cm}^2$$

$$W_{tr} = \frac{1.2 \cdot 30^2}{6} = 180 \text{ cm}^3$$

$$\sigma = \frac{3409.92}{180} = 18.94 \text{ kN/cm}^2 < R_y \gamma_c = 24 \text{ kN/cm}^2$$

$$\tau = \frac{1.5Q}{A_{tr}} = \frac{1.5 \cdot 178.53}{36} = 7.44 \text{ kN/cm}^2$$

$$\sigma_{red} = \sqrt{\sigma^2 + 3\tau^2} \leq 1.15 R_y \gamma_c$$

$$\sigma_{red} = \sqrt{18.94^2 + 3 \cdot 7.44^2} = 22.91 \text{ kN/cm}^2 < 1.15 \cdot 24 \cdot 1 = 27.6 \text{ kN/cm}^2$$

Conclusion: the strength of traverse is provided.

### Calculation of anchor plates

Anchor plates are calculated on carrying capacity of bolts.

Rating scheme of anchor plates:

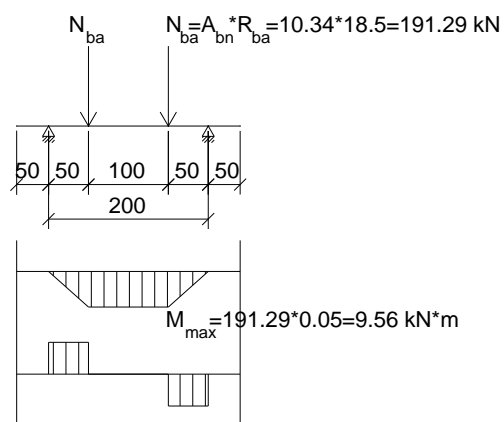

Assume width of anchor plate 200mm.



$$W_{nec} = \frac{M}{R_y \gamma_c} = \frac{9.56}{24 \cdot 1} = 0.4 \text{ cm}^2$$

$$C255 (10 \dots 20 \text{ mm}) R_y = 240 \text{ MPa}$$

$$t_{a,p} = \sqrt{\frac{6M}{b_{a,p}}} = \sqrt{\frac{6 \cdot 0.4}{20}} = 0.35 \text{ cm}$$

Assume  $t_{a,p} = 10 \text{ mm}$  (sheet steel 12 mm – 2 mm for milling).

#### 4.2.5. Conclusions

The use of pre-stress significantly increases the load-bearing capacity of the truss and its rigidity, and therefore allows you to reduce the construction height of the structure and get steel savings of up to 25-30 % compared to the traditional solution. But at the same time, the complexity of manufacturing the farm increases, since the work on pre-tension is transferred to the construction site.

#### 4.3. Calculation of the truss prestressed by tendon

Calculate the values of tendon of tensioning forces and of forces due to external load for an arch-type truss (Table 4.1) subjected to a multi-stage test. First, it is necessary to assume, as for any statically indeterminate system, the cross sections and to determine the load-carrying capacity of bars of the top  $N_t$  and the bottom  $N_b$  chords (see two first columns in Table 4.1). The following columns of the table list the forces due to unit tensioning and to unit load.

It is readily apparent from Table 2.2 that the check bars will be the member f-g of the top chord and the member n-o of the bottom chord, in which  $C_t=13.57$  and  $C_b=4.34$ .

Compute coefficients of relief  $k_1$  and  $k_2$  for the check bars:

$$k_1 = 1 - Q_1 = 1 - \frac{4.34 - 2.71}{4.34} = 0.625$$

$$k_2 = 1 - Q_2 = 1 - \frac{13.57 - 5.46}{13.57} = 0.404 .$$



Calculate the tensioning forces from formulas (2.24) and (2.25):

$$X_1 = \frac{N_b}{C_b} = \frac{352}{4.34} = 81 \text{ kN}$$

$$X_2 = \frac{1}{4.34} (352 \times 0.625 + 395) 0.404 = 57 \text{ kN}$$

$$X_3 = \frac{1}{4.34} (352 \times 0.625 + 395) 0.625 \times 0.404 = 14.3 \text{ kN}$$

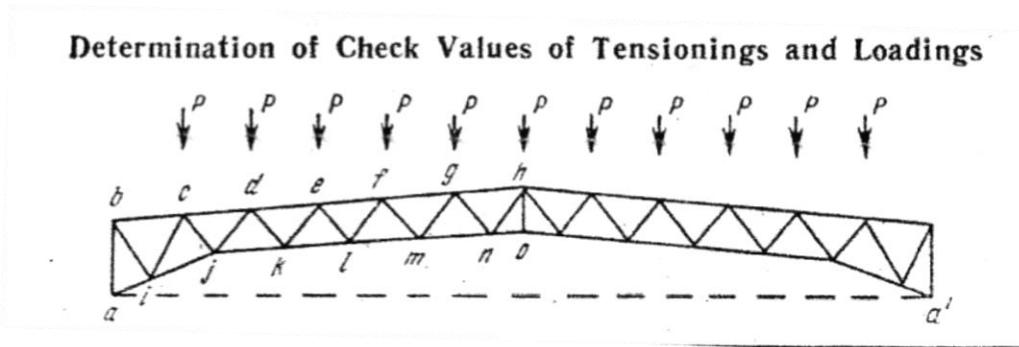

Table 4.1

| Designation of bars |      | Capacity of bars in tension mRF, kN | Capacity of bars in compression mRF, kN | Force from unit tensioning of tendon N=1 | Forces from unit loads P=1 | $X_1 = \frac{N_b}{C_b} = 81 \text{ kN}$ | $P_1 = \frac{395 + 219}{13.57} = 45.2 \text{ kN}$ | Total force, kN | $X_2 = \frac{352 - 105}{4.34} = 57 \text{ kN}$ | $P_2 = \frac{154}{13.57} = 11.3 \text{ kN}$ | Total force, kN | $X_3 = \frac{352 - 290}{4.34} = 14.3 \text{ kN}$ | $P_3 = \frac{39}{13.57} = 2.9 \text{ kN}$ | Final force in bars, kN |
|---------------------|------|-------------------------------------|---|--|----------------------------|---|---|-----------------|--|---|-----------------|--|---|-------------------------|
| Top chords          | a-a' | +520                                | -                                       | +1                                       | +5.71                      | -81                                     | +268  | +349            | +57  | +64.5                                       | +470.5          | +14.3  | +16.4                                     | +501.2                  |
|                     | b-c  | +483                                | -395                                    | +0.4                                     | -1.82                      | +32.4                                   | -82.2   | -49.9           | +22.8  | -20.  | -47.7           | +5.7   | -5.3                                      | -47.3                   |
|                     | c-d  | +483                                | -395                                    | +1.48                                    | -5.41                      | +120                                    | -244  | -124            | +84  | -62   | -101            | +21  | -15.5                                     | -95.5                   |
|                     | d-e  | +483                                | -395                                    | +1.89                                    | -9.38                      | +153                                    | -424  | -271            | +108   | -106  | -269            | +27  | -27                                       | -269                    |
|                     | e-f  | +483                                | -395                                    | +2.3                                     | -12.12                     | +186                                    | -549  | -363            | +131   | -137  | -369            | -33  | -35                                       | -371                    |
|                     | f-g  | +483                                | -395                                    | +2.71                                    | -13.57                     | +219                                    | -614  | -395            | +154   | -154  | -305            | +39  | -39                                       | -395                    |
|                     | g-h  | +483                                | -395                                    | +3.12                                    | -12.46                     | +252                                    | -564  | -312            | +177   | -141  | -276            | +45  | -36                                       | -267                    |
| Bottom chors        | a-i  | +584                                | -548                                    | -1.08                                    | -6.1                       | -87.5                                   | -279  | -366.5          | -61.5  | -69.6                                       | -497.6          | -154   | -17.8                                     | -531.8                  |
|                     | i-j  | +584                                | -530                                    | -1.89                                    | -2.45                      | -153                                    | -110.8  | -263.8          | -107.8   | -27.7                                       | -399.3          | -27  | -7.1                                      | -433.4                  |
|                     | j-k  | +358                                | -318                                    | -2.7                                     | +2.24                      | -218                                    | +101  | -117            | -153   | +25   | -245            | -39  | +6  | -278                    |
|                     | k-l  | +358                                | -318                                    | -3.11                                    | +4.96                      | -252                                    | +224  | -28             | -177   | +56   | -139            | -45  | +14                                       | -170                    |
|                     | l-m  | +358                                | -318                                    | -3.52                                    | +7.67                      | -285                                    | +347  | +62             | -200   | +87   | -51             | -50  | +22                                       | -79                     |
|                     | m-n  | +358                                | -318                                    | -3.93                                    | +7.86                      | -318                                    | +355  | +37             | -223   | +89   | -97             | -56  | +23                                       | -130                    |
|                     | n-o  | +358                                | -352                                    | -4.34                                    | +5.46                      | -352                                    | +247  | -105            | -247   | +62   | -290            | -62  | +16                                       | -336                    |



Calculate the loads upon a single joint with the aid of formula (2.23):

$$P_1 = \frac{1}{13.57} (352 \times 0.625 + 395) 1 = 45.2 \text{ kN}$$

$$P_2 = \frac{1}{13.57} (352 \times 0.625 + 395) 0.625 \times 0.404 = 11.3 \text{ kN}$$

$$P_3 = \frac{1}{13.57} (352 \times 0.625 + 395) (0.625 \times 0.404)^2 = 2.9 \text{ kN}$$

Value  $p_3$  is small, and it is evident that further tensioning and loading stages will be ineffective.

The total load upon the truss joint

$$\Sigma P = 45.2 + 11.3 + 2.9 = 59.4 \text{ kN}$$

The ultimate load upon the truss after an infinite number of pre-stressing cycles, as given by formula (5.36), is

$$P_{\text{lim}} = \frac{395 + 0.625 \times 352}{13.57(1 - 0.625 \times 0.404)} = 60.7 \text{ kN}$$

It is readily apparent that three loading stages suffice to exhaust fully the limit load-carrying capacity of the truss.



## Statical calculation of 2D truss

The statical calculation of the frame is done with the help of program complex LIRA-SAPR [45], [46].

Загружение 1

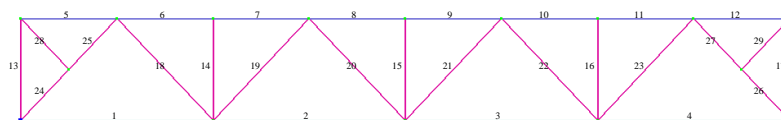

**Fig. 4.10.** Scheme of the truss

Загружение 1

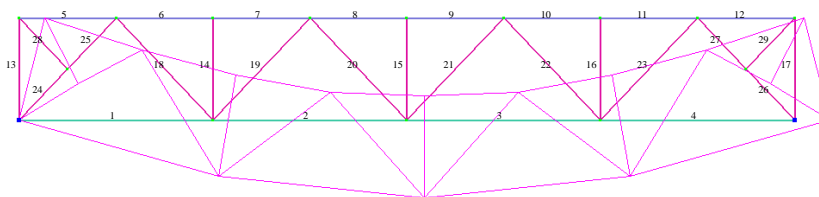

**Fig. 4.11.** Deformed scheme of the truss

Загружение 1  
Эшера N  
Единица измерения - кН

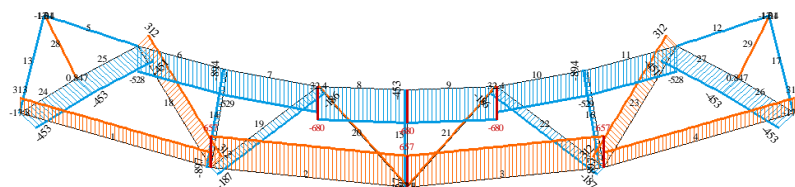

Минимальное усилие -679.606; Максимальное усилие 657.312

**Fig. 4.12.** Load case 1, diagram N







Загружение 1  
Эпюра N  
Единицы измерения - кН

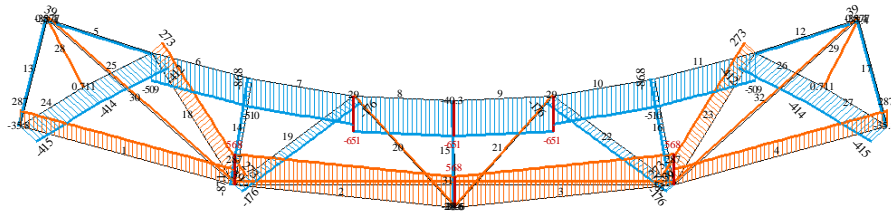

Минимальное усилие -650.73; Максимальное усилие 567.693

**Fig. 4.16.** Load case 1, diagram N

Загружение 1  
Эпюра M<sub>y</sub>  
Единицы измерения - кН\*м

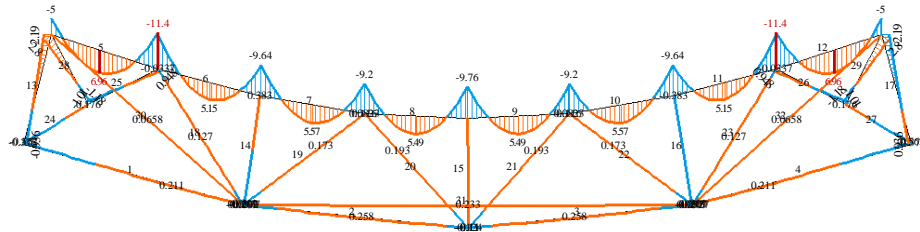

Минимальное усилие -11.3733; Максимальное усилие 6.95628

**Fig. 4.17.** Load case 1, diagram M

**Analysis of steel framework of the structure by using the program complex  
LIRA-SAPR**



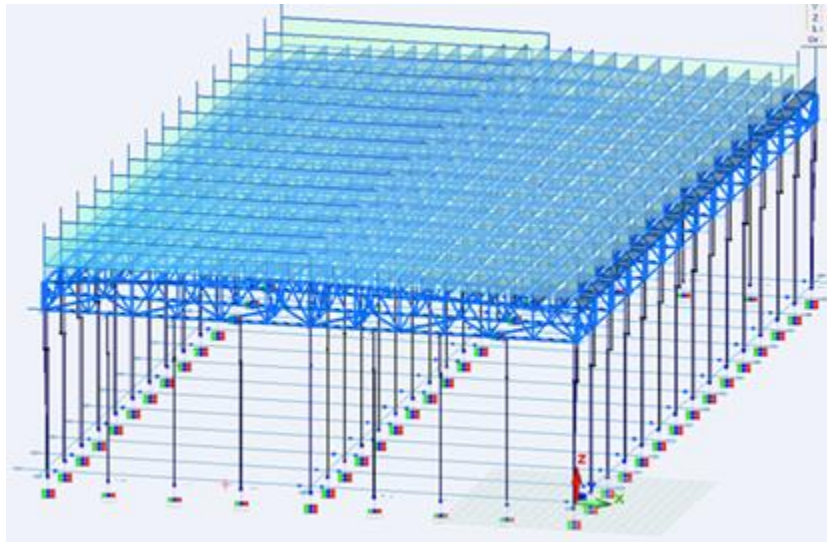

**Fig. 4.18.** Calculation model

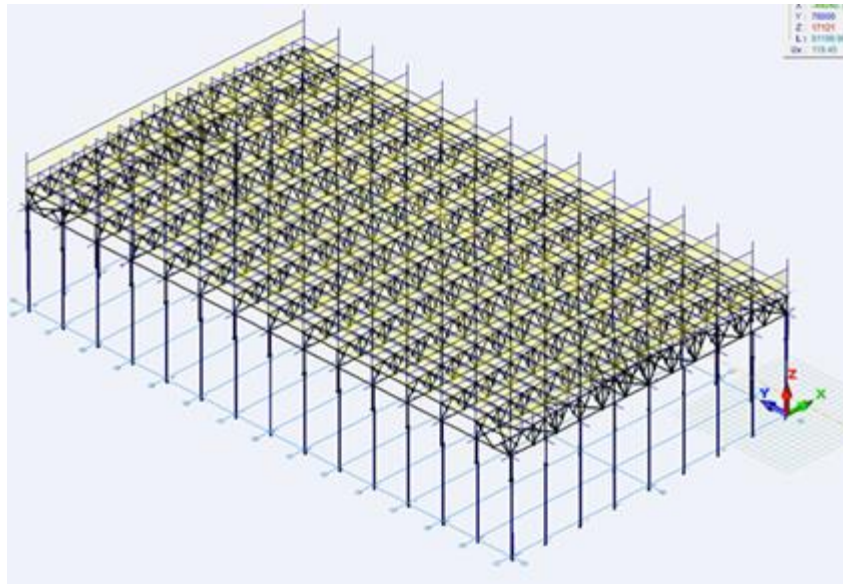

**Fig. 4.18.** Analytical model



**CHAPTER 5**  
**BASES AND FOUNDATIONS**



## 5.1. Calculation of the pile foundation

To calculate eccentrically loaded pile foundation under column of civil building according to the initial data:

1. Geological data is given below.
2. The landform of the area under design is natural slope directed to west.
3. Seismic zone of region is 5.
4. Water has not corrosive condition to the concrete.
5. The soil freezing depth is 1.2m.
6. Building without basement.
7. Cross-section of column 496x1100 mm.
8. The load, which acts on the foundation  $M = -369.86 \text{ kN}\cdot\text{m}$ ,  $N = 1622.44 \text{ kN}$ ,  $V = 66.12 \text{ kN}$ .

### Calculation

#### 5.1.1. Determine the foundation depth:

- From geological conditions:  $d_1 = h_f + 0.5 = 0.3 + 0.5 = 0.8 \text{ m}$ ;
- From climatic conditions: the normative freezing depth -  $d_{fn} = 1.2 \text{ m}$ . Considering the structure of floor and temperature in the room  $t = 10^\circ \text{ C}$  determine that  $K_h = 0.9$  (table 3.1).

Then the calculated freezing depth is  $d_f = K_h \cdot d_{fn} = 0.9 \cdot 1.2 = 1.08 \text{ m}$ .

The level of the foundation is appointed not less than 20 cm below of calculated freezing depth:  $d_2 = d_f + 0.2 = 1.08 + 0.2 = 1.3 \text{ m}$ .

- By the structural features: the level of upper edge of foundation grill is assumed – 0.6m. The thickness of foundation grill is assumed previously 0.4m and subsequently is specified by the calculation on pressing through.

By the structural requirements  $d_p = 0.6 + 0.4 = 1.0 \text{ m}$ .



Assume depth of foundation grill  $d_p = 1.0m$ .

Considering the obtained data, selecting the largest of calculated values, finally we assume the foundation depth at depth  $d = 1.3m$  from the surface.

### 5.1.2. Determine bearing capacity of pile along the soil.

Determine the length of pile. Analyzing the soil conditions and physical and mechanical properties of soils it's possible make sure that plastic sandy clay has small calculating resistance under вістря of the pile, thus it must be cut deepening the pile in middle-sized sand minimum on 0.8...1.0m.

Then the necessary length of pile must be  $l_{pile} = 0.3 + (6.7 - 1.3) + 1.0 = 6.7m$ .

Assume by the ГОСТ (appendix 3) pile C70-30 (length 70dm, cross-section 30x30cm).

Make the calculating scheme near geological column (figure 1) and determine the bearing capacity of pile along the soil [47].

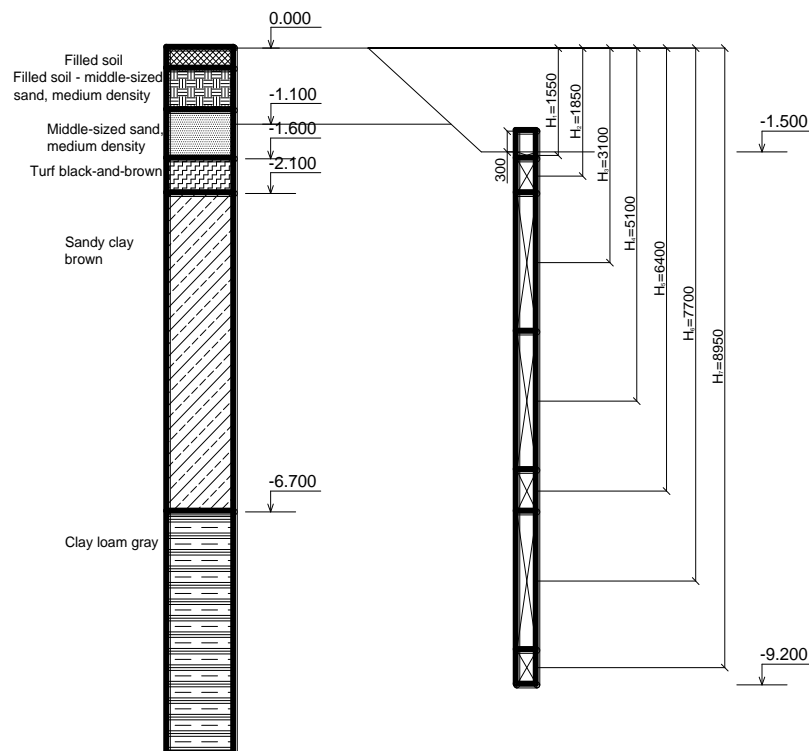

The bearing capacity of friction pile is determined by the formula:

$$F_d = \gamma_c \left( \gamma_{cR} RA + u \sum_{i=1}^u \gamma_{cf,i} \cdot h_i \cdot f_i \right)$$



where  $\gamma_c = 1$ ;  $\gamma_{cR} = 1$ ;  $\gamma_{cf}$  – at deepening of piles by diesel-hammers (table 4.1).

$A = 0.3 \cdot 0.3 = 0.09 \text{ m}^2$  – area of transversal cross-section of pile;

$U = 4 \cdot 0.3 = 1.2 \text{ m}$  – external perimeter of pile;

Depth of the bottom end of pile from natural relief  $H = 8.0 \text{ m}$ .

The calculating resistance  $R$  of soil under bottom end of pile determine from the table 5.1 (for middle-sized sand with the interpolation along the depth).

Table 5.1

| Depth of deepening of pile end, m |             |                | Formula of interpolation   |
|-----------------------------------|-------------|----------------|--|
| 7 ( $y_1$ )                       | 8.0 ( $y$ ) | 10 ( $y_2$ )   | $\frac{x - x_1}{x_1 - x_2} = \frac{y - y_1}{y_1 - y_2}$                      |
| 850 ( $x_1$ )                     | $x$         | 1050 ( $x_2$ ) | $R_x = 850 + \frac{1050 - 850}{10 - 7} \cdot (8.0 - 7) = 916.67 \text{ kPa}$ |

Calculating resistance of soil along the lateral surface of pile determine from the table 4.3. For this divide the thickness into layers (not more than 2.0m) and determine average depth of location of layer from the soil surface. The layer of middle-sized soil is divided into one layer – 0.3m, turf black-and-brown – 0.5m, sandy clay with thickness 4.6m divide into three parts, clay loam gray – into one layer – 1.3m:

$$h_1 = 0.3 \text{ m}; h_2 = 0.5 \text{ m}; h_3 = 2.0 \text{ m}; h_4 = 2.0 \text{ m}; h_5 = 0.6 \text{ m}; h_6 = 1.3 \text{ m}.$$

Pile is deepening in clay loam on  $h_6 = 1.3 \text{ m} < 2 \text{ m}$ .

The average depth of location of elementary layers will be:

$$H_1 = 1.3 + \frac{0.3}{2} = 1.45 \text{ m};$$

$$H_2 = 1.3 + 0.3 + \frac{0.5}{2} = 1.85 \text{ m}; \quad (\text{see figure 1})$$

$$H_3 = 1.3 + 0.3 + 0.5 + \frac{2.0}{2} = 3.1 \text{ m};$$

$$H_4 = 1.3 + 0.3 + 0.5 + 2.0 + \frac{2.0}{2} = 5.1 \text{ m};$$



$$H_5 = 1.3 + 0.3 + 0.5 + 2.0 + 2.0 + \frac{0.6}{2} = 6.4 m;$$

$$H_6 = 1.3 + 0.3 + 0.5 + 2.0 + 2.0 + 0.6 + \frac{1.3}{2} = 7.35 m.$$

The value of specific friction along the lateral side  $f_i$  for each calculating element within layer of sandy clay determine by double interpolation at first by the flow index  $I_L$ , and then by the depth of layer location of soil  $H_i$  (analogically to the determining of quantity  $R_0$  for clay loam by п.Б.5.2 example №1). Interpolation is doing for sand only by  $H$ .

Table 5.2

| Depth of deepening of pile end, m |              |              | Formula of interpolation  |
|-----------------------------------|--------------|--------------|---|
| 1 ( $y_1$ )                       | 1.45 ( $y$ ) | 2 ( $y_2$ )  | $\frac{x - x_1}{x_1 - x_2} = \frac{y - y_1}{y_1 - y_2}$         |
| 23 ( $x_1$ )                      | $x$          | 30 ( $x_2$ ) | $R_x = 23 + \frac{30 - 23}{2 - 1} \cdot (1.45 - 1) = 26.15 kPa$ |
| 1 ( $y_1$ )                       | 1.85 ( $y$ ) | 2 ( $y_2$ )  |   |
| 23 ( $x_1$ )                      | $x$          | 30 ( $x_2$ ) | $R_x = 23 + \frac{30 - 23}{2 - 1} \cdot (1.85 - 1) = 28.95 kPa$ |

Table 5.3

| Depth of deepening of pile end, m | Flow index    |              |               | Formula of interpolation   |
|-----------------------------------|---------------|--------------|---------------|--|
|                                   | 0.3 ( $y_1$ ) | 0.32 ( $y$ ) | 0.4 ( $y_2$ ) |  |
| 3 ( $H_1$ )                       | 35 ( $x_1$ )  | $x$ or $f_3$ | 25 ( $x_2$ )  | $x = f_3 = 35 + \frac{0.32 - 0.3}{0.3 - 0.4} \cdot (30 - 21) = 33.2 kPa$ |
| 3.1 ( $H_{3.1}$ )                 |               | $f_{3.1}$    |               | $f_{3.1} = 33.2 + \frac{35.8 - 33.2}{4 - 3} \cdot (3.1 - 3) = 33.46 kPa$ |





|             |              |              |              |  |
|-------------|--------------|--------------|--------------|--|
| 4 ( $H_4$ ) | 38 ( $x_1$ ) | $x$ or $f_4$ | 27 ( $x_2$ ) | $x = f_4 = 38 + \frac{0.32 - 0.3}{0.3 - 0.4} \cdot (38 - 27) = 35.8 \text{ kPa}$ |
|-------------|--------------|--------------|--------------|--|

Table 5.4

| Depth of deepening of pile end, m | Flow index    |              |               | Formula of interpolation<br>$\frac{x - x_1}{x_1 - x_2} = \frac{y - y_1}{y_1 - y_2}; \frac{f_{5.1(6.4),(7.7)} - f_5}{f_5 - f_8} = \frac{H_{5.1(6.4),(7.7)} - H_5}{H_5 - H_8}$ |
|-----------------------------------|---------------|--------------|---------------|--|
|                                   | 0.3 ( $y_1$ ) | 0.32 ( $y$ ) | 0.4 ( $y_2$ ) |  |
| 5 ( $H_5$ )                       | 40 ( $x_1$ )  | $x$ or $f_5$ | 29 ( $x_2$ )  | $x = f_5 = 40 + \frac{0.32 - 0.3}{0.3 - 0.4} \cdot (42 - 29) = 37.4 \text{ kPa}$   |
| 5.1 ( $H_{5.1}$ )                 |               | $f_{5.1}$    |               | $f_{5.1} = 37.4 + \frac{5.1 - 5}{5 - 8} \cdot (37.4 - 41.8) = 37.55 \text{ kPa}$   |
| 6.4 ( $H_{6.4}$ )                 |               | $f_{6.4}$    |               | $f_{6.4} = 37.4 + \frac{6.4 - 5}{5 - 8} \cdot (37.4 - 41.8) = 39.45 \text{ kPa}$   |
| 7.35 ( $H_{7.35}$ )               |               | $f_{7.35}$   |               | $f_{7.35} = 37.4 + \frac{7.35 - 5}{5 - 8} \cdot (37.4 - 41.8) = 40.85 \text{ kPa}$   |
| 8 ( $H_8$ )                       | 44 ( $x_1$ )  | $x$ or $f_8$ | 33 ( $x_2$ )  | $x = f_8 = 44 + \frac{0.32 - 0.3}{0.3 - 0.4} \cdot (44 - 33) = 41.8 \text{ kPa}$   |

Table 5.5

| Sandy loam, porosity index, $e$ | Flow index    |              |               | Formula of interpolation<br>$\frac{x - x_1}{x_1 - x_2} = \frac{y - y_1}{y_1 - y_2}; \frac{x_0 - x_A}{x_A - x_B} = \frac{y_0 - y_A}{y_A - y_B}$ |
|---------------------------------|---------------|--------------|---------------|--|
|                                 | 0.0 ( $y_1$ ) | 0.23 ( $y$ ) | 0.1 ( $y_2$ ) |  |
| 0.5 ( $y_A$ )                   | 300 ( $x_1$ ) | $x(x_A)$     | 250 ( $x_2$ ) | $R_A = 300 + \frac{0.23 - 0.0}{0.0 - 1.0} \cdot (300 - 250) = 288.5 \text{ kPa}$   |
| 0.61 ( $y_0$ )                  |               | $x_0$        |               | $R_0 = 288.5 + \frac{0.61 - 0.5}{0.5 - 0.7} \cdot (288.5 - 233.9) = 258.47 \text{ kPa}$  |
| 0.7 ( $y_B$ )                   | 250 ( $x_1$ ) | $x(x_B)$     | 180 ( $x_2$ ) | $R_A = 250 + \frac{0.23 - 0.0}{0.0 - 1.0} \cdot (250 - 180) = 233.9 \text{ kPa}$   |



Table 5.6

| Depth of deepening of pile end, m |             |              | Formula of interpolation   |
|-----------------------------------|-------------|--------------|--|
| 8 ( $y_1$ )                       | 8.0 ( $y$ ) | 10 ( $y_2$ ) | $\frac{x - x_1}{x_1 - x_2} = \frac{y - y_1}{y_1 - y_2}$                      |
| 62 ( $x_1$ )                      | $x$         | 65 ( $x_2$ ) | $R_x = 3700 + \frac{4000 - 3700}{10 - 7} \cdot (8.0 - 7) = 3800 \text{ kPa}$ |

Obtained results enter in the table 5.7.

Table 5.7

| Number of calculating element                              | $H_i, m$ | $f_i, kPa$ | $h_i, m$ | $\gamma \cdot c \cdot f$ | $f_i \cdot h_i \cdot \gamma \cdot c \cdot f, kN/m$ |
|--|----------|------------|----------|--------------------------|--|
| 1  | 1.45     | 26.15      | 0.3      | 1.0                      | 7.85   |
| 2  | 1.85     | 28.95      | 0.5      | 1.0                      | 14.48  |
| 3  | 3.1      | 33.46      | 2.0      | 1.0                      | 66.92  |
| 4  | 5.1      | 37.55      | 2.0      | 1.0                      | 75.1   |
| 5  | 6.4      | 39.45      | 0.6      | 1.0                      | 23.67  |
| 6  | 7.35     | 40.85      | 1.3      | 1.0                      | 53.11  |
| Total: $\sum f_i \cdot h_i \cdot \gamma \cdot c \cdot f =$ |          |            |          |                          | 240.83   |

Determine the bearing capacity of pile along the soil:

$$F_d = 1 \cdot (1 \cdot 3800 \cdot 0.09 + 1.2(1 \cdot 26.15 \cdot 0.3 + 1 \cdot 28.95 \cdot 0.5 + 1 \cdot 33.46 \cdot 2.0 + 1 \cdot 37.55 \cdot 2.0 + 1 \cdot 39.45 \cdot 0.6 + 1 \cdot 40.85 \cdot 1.3)) = 342 + 1.2 \cdot 251.2 = 631 \text{ kN}$$

Because at determining of quantities  $R$  and  $f$  were used the normative table values, according to the requirements [4] inclusive of coefficient of reliability along the soil  $\gamma_g = 1.4$  the guaranteed bearing capacity of pile constitutes:



$$F_{d.g} = \frac{F_d}{\gamma_g} = \frac{631}{1.4} = 450.71 \text{ kN}.$$

Pile foundation is calculated by the 1-st limiting state, thus load is determined at average coefficient of reliability by load which is equal  $\gamma_f = 1.2$ :

$$N_1 = N_n \cdot \gamma_f = 1622.44 \cdot 1.2 = 1946.93 \text{ kN};$$

$$M_1 = M_n \cdot \gamma_f = 369.86 \cdot 1.2 = 443.83 \text{ kN};$$

$$T_1 = T_n \cdot \gamma_f = 66.12 \cdot 1.2 = 79.34 \text{ kN}.$$

Determine the quantity of piles in the foundation:

$$n = \frac{N_1 \cdot k_m}{F_{d.g}} = \frac{1946.93 \cdot 1.09}{451.71} = 4.7 \text{ units};$$

$$\text{where } k_m = 1 + \frac{\sum M_1}{3 \cdot N_1} = 1 + \frac{443.83 + 79.34 \cdot (1.5 - 0.5)}{3 \cdot 1946.93} = 1.09 \text{ – coefficient that takes into}$$

consideration eccentric load.

Assume 5 piles in the foundation and set their on the minimum distance  $3d$  (figure 1).

The distance between axes of piles is:

$$L_{oc} \frac{3d}{\sqrt{2}} = \frac{900}{1.41} = 638 \text{ mm}. \text{ Assume } L_{oc} = 650 \text{ mm}; \text{ multiple } 50 \text{ mm}.$$

Assume ledges of foundation grill for lateral sides of pile  $0.1 \text{ m}$ , that is more than  $(0.05 + 0.15 \cdot 0.3) = 0.095 \text{ m}$ .

The dimensions of foundation grill in plan:

$$b = a = 2 \cdot L_{oc} + d + 2 \cdot 100 = 2 \cdot 650 + 300 + 200 = 1800 \text{ mm}.$$

Construct the pile foundation and check the load on pile – see formulas (4.9...4.11).

Determine weight of foundation grill and soil on its edges:

$$F_{1,p} = 2.6 \cdot 2.6 \cdot 1.3 \cdot 1.1 \cdot 20 = 193.34 \text{ kN}.$$

General load:

$$\sum N_1 = N_1 + F_{1,p} = 1946.93 + 193.34 = 2140.27 \text{ kN}$$

$$\sum M_1 = M_1 + T_1 \cdot h_p = 443.83 + 79.34 \cdot (1.3 - 0.6) = 500 \text{ kN}$$



$$N_{\max, \min} = \frac{2140.27}{5} \pm \frac{500 \cdot 0.1}{0.1^2 \cdot 4} = 428.05 \pm 113.64 \text{ kN} \cdot \text{m}$$

$$N_{\text{average}} = 428.05 \text{ kN} < F_{d.g} = 450.71 \text{ kN}$$

$$N_{\max} = 428.05 + 113.64 = 541.69 \text{ kN} < 1.2 \cdot 450.71 = 542.05 \text{ kN}$$

$$N_{\min} = 428.05 - 113.64 = 314.41 \text{ kN} > 0$$

All checkups are used. So, the foundation is designed correctly.

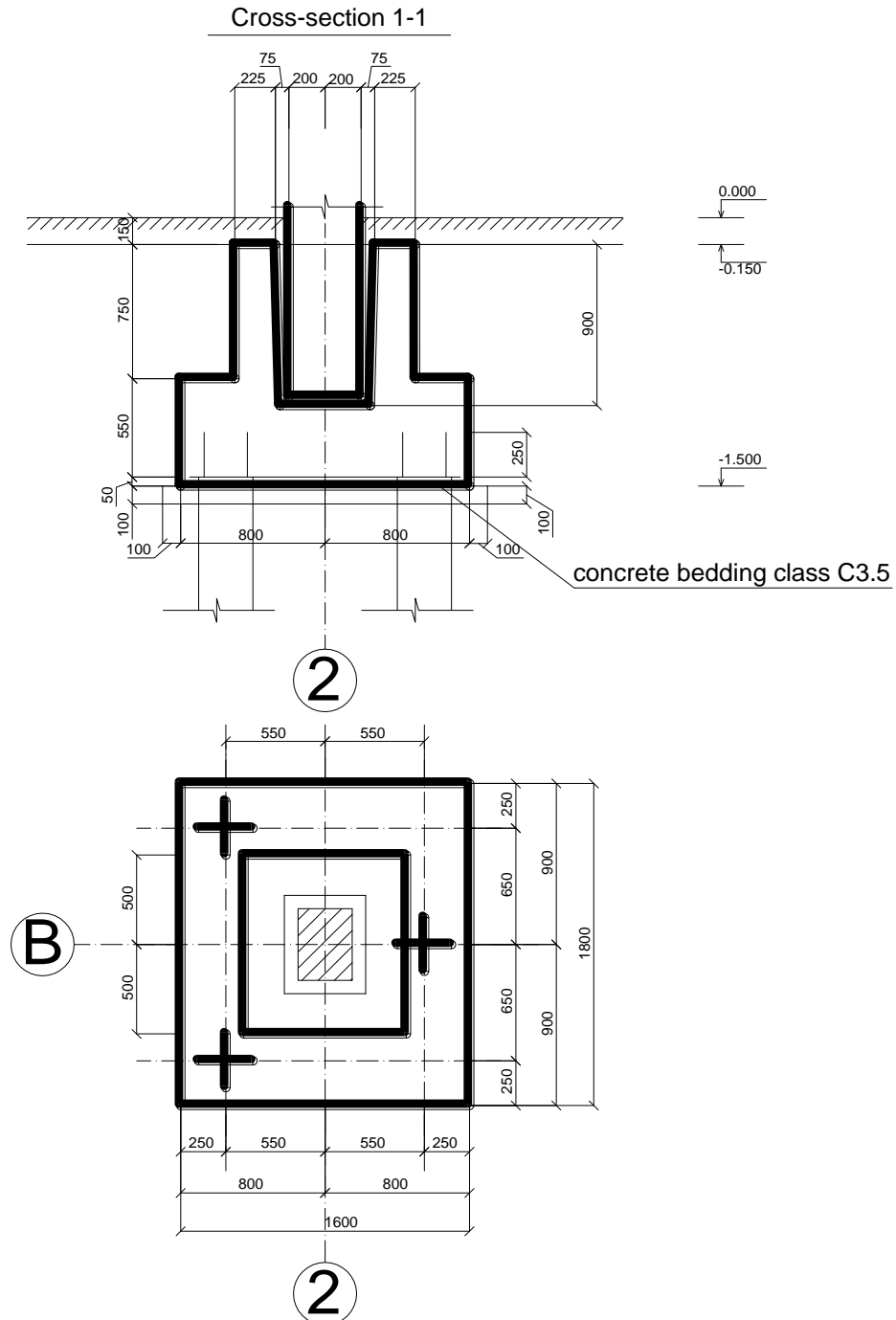

**Figure 5.2.** The scheme of the assumed variant of the foundation



## 5.2. Checking of weak underlying layer of sandy loam

For sandy loam:  $\varphi=17^\circ$ ,  $c_{II}=5$  kPa.

The condition should be:

$$\sigma_{zp} + \sigma_{zq} \leq R_z$$

Vertical stress from dead load of soil at the depth 8.0 m from level of design by cutting:

$$\sigma_{zq} = \gamma \cdot z = 18.91 \cdot 3.65 = 69 \text{ kPa}$$

Additional pressure at the depth z from the foundation base:

$$\sigma_{zp} = \alpha(p_{average} - \sigma_{zq}), \text{ where } \alpha - \text{coefficient defined by the table B.4. appendix B}$$

according to:

$$\xi = \frac{2z}{b} = \frac{2 \cdot 1.55}{2.4} = 1.29 \text{ and } \eta = \frac{l}{b} = \frac{2.6}{2.6} = 1.0,$$

$$\alpha = 0.607$$

$$\sigma_{zp} = 0.607 \cdot (231.37 - 69) = 98.56 \text{ kPa}$$

Area of conditional foundation:

$$A_z = \frac{N'}{\sigma_{zp}} = \frac{N + d_1 \cdot \rho \cdot b \cdot l}{\sigma_{zp}} = 20.08 \text{ m}^2$$

Width of conditional foundation:

$$b_z = \sqrt{A_z + a^2} - a = \sqrt{20.08 + 0.45^2} - 0.45 = 4.05 \text{ m},$$

$$\text{where } a = \frac{l - b}{2} = \frac{3.3 - 2.4}{2} = 0.45 \text{ m}.$$

Calculated soil resistance under the base of conditional foundation:



$$R_z = \frac{\gamma_{c1} \cdot \gamma_{c2}}{k} (M_\gamma k_z b_z \gamma_{II} + M_q d_z \gamma'_{II} + M_c c_{II}) =$$

$$= \frac{1.1 \cdot 1}{1} \cdot (0.39 \cdot 1 \cdot 4.05 \cdot 17.93 + 2.57 \cdot 2.25 \cdot 18.91 + 5.15 \cdot 5) = 179.76 \text{ kPa}$$

where  $\gamma_{c1}=1,1$ ;

$M_c=5,15$ ;

$\gamma_{c2}=1$ ;

$k_z=1$ ;

$k=1$ ;

$\gamma_{II}=17,93 \text{ kN/m}^3$ ;

$M_\gamma=0,39$ ;

$\gamma'_{II} = 18.91 \text{ kN/m}^3$ ;

$M_q=2,57$ ;

$c_{II}=5 \text{ kPa}$ ;

$d_z=2.25 \text{ m}$ .

$$\sigma_{zp} + \sigma_{zq} = 167.56 \text{ kPa} \leq R_z = 179.76 \text{ kPa}$$

The condition is satisfied that accepted dimensions of the foundation are retained without changes.

### 5.3. Determination of final settlement of the foundation base by the method of layered summation

Calculation is made on the assumption of condition:

$$S \leq S_u,$$

where  $S$  – mutual deformation of the base and structure determined by calculation,

$S_u$  – limit value of mutual deformation of the base and structure accepted by [1].

Settlements of the base are calculated by method of method of layered summation by the formula:

$$S = \beta \cdot \sum_{i=1}^n \frac{\sigma_{zp,i} \cdot h_i}{E_i},$$

where  $\beta=0,8$  – non-dimensional coefficient,



$\sigma_{zp,i}$  – average value of additional stress in i layer of soil equaled semisum of indicated stresses bon upper and bottom limits of layer;

$h_i$  and  $E_i$  – correspondently thickness and modulus of deformation of soil layer;

$n$  – number of layers on which compressed thick of the base is broken.

Vertical stress from dead load of soil at the limit of layer located at the depth  $z$  from foundation base is defined by the formula [25]:

$$\sigma_{zg} = \sigma_{zq,0} + \sum_{i=1}^n \gamma_i \cdot h_i = \gamma' \cdot d_n + \sum_{i=1}^n \gamma_i \cdot h_i,$$

where  $\gamma'$  - specific weight of soil located above the foundation base;

$\gamma_i$  and  $h_i$  - specific weight and thickness of i soil layer;

$\sigma_{zg,0}$  - vertical stress from dead load of soil at the level of foundation base;

$d_n$  – depth of foundation from the surface of natural relief.

Additional vertical stresses at the level  $z$  from the foundation base are determined by the formula [24]:

$$\sigma_{zp} = \alpha \cdot p_0,$$

where  $\alpha$  – coefficient, accepted by the table 8 (appendix 2) [1] in dependence from relative depth  $\xi = \frac{2z}{b}$  and correspondence of sides of rectangle foundation  $\eta$ ;

$p_0$  – additional vertical pressure under base of foundation:

$$p_0 = p_{average} - \sigma_{zg,0}.$$

Bottom limit of compressed thickness of the base to which is made summation of settlements accept at the depth where is fulfilled condition:  $\sigma_{zp} = 0.2\sigma_{zg}$



Uniform layers of the base lower the foundation base are broken by layers with thickness  $h_i \leq 0.4 \cdot b = 0.4 \cdot 2.6 = 1.04 \text{ m}$ .

$$\sigma_{z_g,0} = 18.91 \cdot 8.0 = 151.28 \text{ kPa},$$

$$p_0 = 231.37 - 151.28 = 80.09 \text{ kPa}$$

1.  $z=0.5$

$$\sigma_{z_g} = \sigma_{z_g} + \sum \gamma \cdot h = 151.28 + 18.91 \cdot 0.5 = 160.74 \text{ kPa}$$

$$\xi = 2 \cdot \frac{z}{b} = 2 \cdot \frac{0.5}{2.6} = 0.4, \quad \eta = \frac{l}{b} = 1.0 \rightarrow \text{by ДБН } \alpha = 0.96$$

$$\sigma_{z_p} = \alpha \cdot p_0 = 0.96 \cdot 80.09 = 76.89 \text{ kPa}$$

2.  $z=1.0\text{m}$

$$\sigma_{z_g} = \sigma_{z_g} + \sum \gamma \cdot h = 151.28 + 18.91 \cdot 1.0 = 170.19 \text{ kPa}$$

$$\xi = 2 \cdot \frac{z}{b} = 2 \cdot \frac{1.0}{2.6} = 0.8, \quad \eta = \frac{l}{b} = 1.0 \rightarrow \text{by ДБН } \alpha = 0.8$$

$$\sigma_{z_p} = \alpha \cdot p_0 = 0.8 \cdot 80.09 = 64.07 \text{ kPa}$$

3.  $z=1.5\text{m}$

$$\sigma_{z_g} = \sigma_{z_g} + \sum \gamma \cdot h = 151.28 + 18.91 \cdot 1.5 = 179.65 \text{ kPa}$$

$$\xi = 2 \cdot \frac{z}{b} = 2 \cdot \frac{1.5}{2.6} = 1.2, \quad \eta = \frac{l}{b} = 1.0 \rightarrow \text{by ДБН } \alpha = 0.606$$

$$\sigma_{z_p} = \alpha \cdot p_0 = 0.606 \cdot 80.09 = 48.53 \text{ kPa}$$

4.  $z=2.0\text{m}$

$$\sigma_{z_g} = \sigma_{z_g} + \sum \gamma \cdot h = 151.28 + 18.91 \cdot 2.0 = 189.1 \text{ kPa}$$

$$\xi = 2 \cdot \frac{z}{b} = 2 \cdot \frac{2.0}{2.6} = 1.6, \quad \eta = \frac{l}{b} = 1.0 \rightarrow \text{by ДБН } \alpha = 0.449$$





$$\sigma_{zp} = \alpha \cdot p_0 = 0.449 \cdot 80.09 = 35.96 \text{ kPa}$$

Bottom limit of compressed thickness to which is made summation of settlements accept at the depth where is fulfilled condition:

$$0.2 \cdot \sigma_{zg} = 0.2 \cdot 189.1 = 37.8 \text{ kPa} > \sigma_{zp} = 35.96 \text{ kPa}$$

Results of calculation are carried to the table 5.8.

Table 5.8.

| Z, m | $\gamma$ ,<br>kN/m <sup>3</sup> | $\gamma_{sb}$ ,<br>kN/m <sup>3</sup> | $\sigma_{zg,0}$ , kPa | $\xi$ | $\alpha$ | $0.2\sigma_{zg,0}$ | $\sigma_{zp}$ , kPa | $\sigma_{zpi}$ , kPa | E,<br>kPa | S, m   |
|------|---------------------------------|--------------------------------------|-----------------------|-------|----------|--------------------|---------------------|----------------------|-----------|--------|
| 0    | 18.91                           | -                                    | 151.28                | 0     | 1        | 30.26              | 80.09               |                      |           |        |
|      |                                 |                                      |                       |       |          |                    |                     | 79.99                | 12890     |        |
| 0.5  | 18.91                           | -                                    | 160.74                | 0.4   | 0.960    | 32.15              | 79.89               |                      |           | 0.0031 |
|      |                                 |                                      |                       |       |          |                    |                     | 71.98                | 12890     |        |
| 1.0  | 18.91                           | -                                    | 170.19                | 0.8   | 0.8      | 34.04              | 64.07               |                      |           | 0.0045 |
|      |                                 |                                      |                       |       |          |                    |                     | 56.3                 | 12890     |        |
| 1.5  | 18.91                           | -                                    | 179.65                | 1.2   | 0.606    | 35.93              | 48.53               |                      |           | 0.0052 |
|      |                                 |                                      |                       |       |          |                    |                     | 42.25                | 12890     |        |
| 2.0  | 18.91                           | -                                    | 189.1                 | 1.6   | 0.449    | 37.82              | 35.96               |                      |           | 0.0052 |
|      |                                 |                                      |                       |       |          |                    |                     |                      |           |        |
|      |                                 |                                      |                       |       |          |                    |                     |                      | $\Sigma$  | 0.018  |

Settlement of the base:

$$S = 0.018 \text{ m} = 1.8 \text{ cm} < S_u = 8 \text{ cm}$$

**Conclusion:** requirements of ДБН are satisfied [23].



**CHAPTER 6**  
**OCCUPATIONAL SAFETY**



## 6.1. Analysis of harmful and dangerous production factors

Productivity and safety largely depend on the organization of the construction site and the order on it. Therefore, the organization of the construction site for the placement of cars, vehicles, driveways, unloading sites, warehouses, workshops, sanitary facilities and devices should be treated with special care.

All elements of fences are marked. The construction site, work areas, workplaces, driveways and approaches to them in the dark are provided with lighting. Lighting should be uniform, should not blind workers. It is forbidden to perform work in unlit places. Spotlights above the work site are installed at a height of at least 6 m on metal mobile inventory supports.

Various sanitary and administrative and economic premises (passages, control room, offices of engineering and technical workers, dressing rooms, showers, dining rooms) are located at the entrance to the construction site.

In the working area of construction and road machines that can be used during earthworks, it is not allowed to perform other work and stay workers. The boundary of the danger zone of the moving working body is 5 m. Soil from the excavation (trenches, ditches), working tools and materials are placed at a distance of not less than 0.5 m from the edge (outer edge), where other engineering communications take place. Therefore, the placement of the movement of road construction machines is carried out outside the prism of the possible collapse of the excavation soil.

According to the standard ГОСТ 12.0.003-74 there are the following harmful and dangerous production factors that may affect the employee:

- the increased dustiness and gassiness of air of a working zone - a physical harmful factor;
- increased noise in the workplace - a physical harmful factor ДСН 3.3.6.037-99 [33].
- increased vibration level - a physical harmful factor ДСН 3.3.6.039-99;
- high or low humidity - a physical harmful factor;



- increased or decreased air temperature of the working area - a physical harmful factor ДСН 3.3.6.042-99 [32], [33];
- physical overload - a psychophysiological harmful factor.

## **6.2. Measures to reduce the impact of harmful and dangerous production factors**

The main cause of accidents when performing earthworks is the blockage of the walls of pits and trenches when the permissible depth of vertical walls is exceeded, instability of slopes, insufficient strength of fastening. The causes of blockage can be: changes in the ground water regime, temperature, vibration and shocks from running machines, soil heterogeneity, and so on.

Technological maps and diagrams for earthworks provide for measures to prevent blockages, ensure soil stability and safety of work, for which horizontal fastening of trenches with boards or shields, risers and spacers is provided.

In order to prevent injuries when performing work in recesses, the calculation of fasteners is necessary if the recess depth is more than 1.5 m.

ДСН А. 3.2-2-2009 [32] system of labor safety standards. Industrial safety in construction involves the development of recesses with vertical walls without fasteners in non-rocky and thawed soils, above the ground water level at a depth of no more than:

- 1.00 m - in loose soils;
- 1.25 m - in sandy loam;
- 1.50 m - in loam and clay.

In the presence of ground water in these conditions, fasteners are mandatory.

According to the requirements of ДСН А. 3.2-2-2009 [32], the production of earth works for the excavation of the pit is carried out in compliance with the following provisions:



- pits and trenches developed in places where people or vehicles are moving are equipped with a protective fence according to ДСТУ Б В. 2.8-43:2011 [34] with warning signs and signal lighting at night;

- transition bridges with lighting at night are being built;

- the soil of the excavation is located no closer than 0.5 m from the edge of the excavation;

- it is not allowed to develop pits and trenches using the "digging " method";

- boulders and stones on the slopes should be removed;

- if it is impossible to use inventory fasteners for the walls of pits and trenches, it is necessary to use fasteners made according to individual projects;

- the upper part of the mount must protrude at least 15 cm above the edge;

- install fasteners from top to bottom as the recess is developed with a gripper depth of no more than 0.5 m;

- development by rotary and trench excavators in connected soils is allowed without attachment to a depth of no more than 3.0 m;

- before allowing workers to enter a pit or trench with a depth of more than 1.3 m, the stability of the slopes and wall fasteners are checked;

- if electric heating of the soil is necessary, the requirements of ГОСТ 12.1.013-78 "Electrical safety. General requirements";

- when developing the soil with buckets, protective canopies are installed over the diggers workplaces and over the aisles;

- loading of soil on dump trucks is carried out from the rear or side;

- it is not allowed to create canopies from the ground;



- when developing, transporting or compacting the soil by two or more self-propelled or trailed vehicles following each other, the distance between them must be at least 10.0 m.

**Noise prevention measures.**

The project envisages:

- when working with power tools and equipment, noise levels exceeding 80DB should be enclosed with acoustic screens.

- Various measures are used to reduce noise levels in the workplace [58; 59; 60; 61]. To combat industrial noise, the following basic measures are used: noise reduction in its source, sound insulation, sound absorption, silencers, architectural and planning measures, personal protective equipment.

**Example**

Determine the required noise reduction. In the workshop there are several noise sources, the characteristics of which are given in Table. 6.1.

**Solution**

The total noise level is determined by the formula:

$$\sum L = 10 \lg(10^{0.1L_1} + 10^{0.1L_2} + \dots + 10^{0.1L_n}), \tag{6.1}$$

where  $L_1, L_2, \dots, L_n$  is the noise level of each source, taking into account their distance to the calculated point, DB.

Table 6.1 - Characteristics of noise sources

| Noise source | Sound Power level, dBA | Distance to the calculated Point, m |
|--------------|------------------------|-------------------------------------|
| 1            | 119                    | 10                                  |
| 2            | 112                    | 8                                   |
| 3            | 122                    | 12                                  |
| 4            | 115                    | 12                                  |
| 5            | 114                    | 9                                   |



Let's calculate the noise level in each source based on the distance to the calculated point using the formula:

$$L_r = L_i - 10 \lg 2\pi r^2, \quad (6.2)$$

$$L_1 = 119 - 10 \lg \cdot 2 \cdot 3.14 \cdot 6^2 = 95.5 \text{ dB}$$

$$L_2 = 112 - 10 \lg \cdot 2 \cdot 3.14 \cdot 8^2 = 86 \text{ dB}$$

$$L_3 = 122 - 10 \lg \cdot 2 \cdot 3.14 \cdot 12^2 = 119 \text{ dB}$$

$$L_4 = 115 - 10 \lg \cdot 2 \cdot 3.14 \cdot 6^2 = 91.5 \text{ dB}$$

$$L_1 = 114 - 10 \lg \cdot 2 \cdot 3.14 \cdot 4^2 = 94 \text{ dB}$$

where  $L_r$  is the noise level at the calculated point, dB;

$L_i$  - noise level in the source located at a distance  $r$  (m) from the design point, dB.

The total noise level is determined by the formula (6.1):

$$\sum L = 10 \lg (10^{0.1 \cdot 95.5} + 10^{0.1 \cdot 86} + 10^{0.1 \cdot 119} + 10^{0.1 \cdot 91.5} + 10^{0.1 \cdot 94}) = 99.7 \text{ dB}$$

As a result, we get that the noise level at the calculated point is 99.7 dBA, which significantly exceeds the permissible level (table. B. 1 Annex B). Calculate the required noise reduction:

$$\Delta L = 99.7 - 80 = 19.7 \text{ dB.}$$

### **Measures of prevention of exposure to harmful substances.**

The project envisages:

- use personal protective equipment in accordance with ДСТУ 7239:2011;
- when performing welding;
- when performing finishing works related to the use of volatile pollutants, perform control of these substances and use personal protective equipment of workers in accordance with ДСТУ 7239:2011 [34].

### **6.3. Occupational Safety Instruction**

The instruction is structured according to the following:

#### **1. General safety requirements**

1.1. Persons at least 18 years of age who have passed through earthworks are allowed to work:



- medical examination and recognized as fit for work in this profession;
- introductory instruction on labor protection, industrial sanitation and fire safety;
- initial training at the workplace;
- checking the knowledge of current workplace instructions and labor protection rules in the Qualification Commission.

1.2. Repeated instruction is conducted in six months. Periodic verification of knowledge on labor protection is carried out at least once a year.

1.3. When new or revised safety rules are put into effect, after an accident or accident that occurred at the enterprise or in the shop (site) due to violation of labor protection rules by employees, and when establishing the facts of unsatisfactory knowledge of labor protection instructions by employees, an extraordinary knowledge check may be appointed.

1.4. The digger is not allowed to work in the following cases::

- when appearing at work under the influence of alcohol or drugs;
- in the absence of workwear, safety shoes and other personal protective equipment in accordance with the current labor protection standards and regulations;
- in case of a painful condition;
- in case of violation of the rules, norms and instructions on labor protection;

1.6. The digger is subordinate to the foreman of the site, and in the process of work – to the foreman and performs only the work that is assigned to him.

1.7. The digger must:

- perform the work on which the master has been instructed and approved, efficiently and on time;
- keep tools, equipment and workplace clean and tidy;





- work only with serviceable tools, devices and mechanisms;
- comply with the internal Labor Regulations, rules for safe work and fire safety.

1.8. The digger worker must be familiar with the dangerous and harmful production factors affecting the employee (risk of injury, falling objects, dustiness of the work area, etc.).

1.9. The digger worker is issued workwear, safety shoes and other personal protective equipment in accordance with standard industry standards.

1.10. For violation of labor protection rules and these instructions, the perpetrators are liable in accordance with the procedure established by the legislation and internal labor regulations.

## **2. Safety Requirements before starting work**

2.1. Earthworks in construction are carried out in a mechanized way. The use of manual labor on earthworks is allowed only in exceptional cases – if they cannot be performed using mechanisms or if the amount of work is insignificant.

2.2. Prior to the start of earthworks on the construction site, geological and hydrogeological surveys are carried out in order to identify the properties of the soil, the regime of ground water, etc.

2.3. On the construction site, all kinds of communications can be located in the ground at different depths: electric cables, gas pipeline, water supply, sewerage, communication line, etc. therefore, it is necessary to obtain a special written permission (order) for the right to perform earthworks from those organizations that include underground communications.

2.4. If there are underground utilities in the earthworks area, work should be carried out with extreme caution under the supervision of the foreman or Master and a representative of the organization to which these communications belong.



2.5. Soil development in the immediate vicinity of underground communication lines is allowed only with the help of diggers. It is forbidden to use crowbars, picks, jackhammers and other tools.

2.6. If any underground utilities or structures that are not shown in the drawings are detected, the work must be stopped immediately, the identified structures must be carefully examined to establish their origin, and with the participation of representatives of interested organizations, the issue of the possibility of continuing earthworks should be resolved.

2.7. When performing earthworks, there are cases of harmful gases appearing in pits and trenches. In these cases, work should be stopped immediately, and workers should be removed from dangerous places until the latter are neutralized and the causes of gas appearance are identified. Only after complete security is established can you continue working. It is forbidden to smoke or use fire in such places, as this may cause an explosion in a dangerous gas-filled area.

2.8. If ammunition is detected, earthworks can be resumed only after checking the site and removing ammunition by sappers.

2.9. When performing preparatory work, mechanisms are used to divert surface and ground water, remove trees, plants, etc. when performing these works, check the serviceability of bulldozers, uprooting machines, the presence of fences in them, the condition of ropes, cables, and braking devices. The presence of unauthorized persons is prohibited.

### **3. Safety Requirements during operation**

3.1. The greatest danger is the digging of ditches and trenches with vertical walls without fastening.

3.2. The depth of holes without fasteners should not exceed:

1 m – in sandy and gravelly soils,



1.25 m – in sandy loam, clay and dry forest soils,

2 m – in particularly dense soils, when developing which manually it is necessary to use crowbars, picks and wedges.

3.3. Digging trenches with Rotary or trench excavators in dense connected soils is allowed with vertical walls without fastening to a depth of no more than 3 m. at the same time, it is not allowed to lower workers into the trench, as vertical walls may collapse.

3.4. In the places of the trench where it is necessary to stay workers, fasteners or slopes should be arranged.

3.5. In soils with a disturbed structure with a high level of ground water, the presence of underground utilities, as well as at a depth of more than 2 m, the vertical walls of pits and trenches must be fixed.

3.6. When digging trenches, ditches and Wells in places of heavy traffic – on streets, in courtyards, squares – around the work sites at a distance of 0.8-1 m from the edge, fence posts with a height of at least 1 m with warning signs are installed.

3.7. Fences should be illuminated at night.

3.8. It is recommended to install side boards at ground level at the edge of a trench or pit.

3.9. Open pits and trenches near roads and residential buildings should be fenced.

3.10. For crossing ditches and trenches, mystics with a width of at least 0.8 m, for one-way traffic, and a width of 1.5 m with railings with a height of at least 1 M, A side board and barriers, for two-way traffic must be arranged. The crossing must be illuminated at night.

3.11. Within the construction site, prepare the paths along which excavators will move. The movement of excavators on artificial structures (bridges, overpasses, pipes under embankments, etc.) is allowed only after a preliminary check of the density of these



structures and obtaining permission for the excavator to pass through the structures from the organizations to which they belong.

3.12. During the movement of the excavator, its boom should be installed strictly in the direction of travel, and the bucket should be raised above the ground by 0.5-0.7 m. It is forbidden to move the excavator with a loaded bucket.

3.13. After preparing the path and passage of the excavator to the place of work, excavation begins in accordance with the technological map and the project of work.

3.14. To prevent unauthorized movement of the excavator during Operation, it must be fixed with portable supports. It is forbidden to put boards, logs, stones, or other objects under the tracks or rollers.

3.15. During the operation of the excavator, it is forbidden to be a worker under the bucket or boom. You cannot perform any other work from the side of the face. Pay special attention to the fact that there are no electrical line wires within the range of the excavator.

3.16. It is not allowed to lift and move pieces of rock, logs, beams, stones, etc. oversized loads with a bucket, as this may wake up the excavator. Load the developed soil on the vehicle with an excavator from the rear or side of the vehicle.

3.17. It should not be allowed that people are between the earthmoving machine and vehicles during soil loading.

3.18. During breaks in work, regardless of their causes and duration, the excavator boom should be moved away from the face at a distance of at least 2 m from the edge of the open trench, and the bucket should be lowered to the ground.

3.19. Earthworks can be performed by tractor scrapers or bulldozers. To prevent scrapers from spilling out, do not approach the pit slopes at a distance of less than 0.5 M and the slopes of a freshly filled embankment at a distance of less than 1 m.

3.20. When working with several scrapers, a distance of at least 20 M must always be maintained between them.



3.21. It is forbidden to move the soil with a bulldozer up or down a slope of more than 30°, as well as to extend the bulldozer knife to the edge of the recess slope.

3.22. Compact the soil with rollers in layers no more than 30 cm thick.

3.23. The soil thrown out of the pit or trench should be placed no closer than 0.5 m from the edge.

#### **4. Safety Requirements after work**

4.1. During a break in work or at the end of a shift, do not sit at the base of the slope, as this may lead to an accident.

4.2. At the end of the work, move the excavator to a distance of at least 2 m from the edge of the trench or send it to the parking place of equipment, lower the bucket to the ground.

4.3. Clean the unit from dust and dirt perform Inter-shift maintenance.

4.4. Inform the Wizard about any shortcomings that have occurred during operation.

4.5. Remove work clothes, arrange them, and hang them in the designated place.

4.6. Wash your hands with soap and water or take a shower.

#### **5. Safety Requirements at emergency situations**

5.1. If any underground utilities or structures that are not shown in the drawings are detected, work must be stopped immediately, and the identified structures must be carefully inspected to establish their origin.

5.2. When performing earthworks, harmful gases may appear in pits and trenches. In these cases, work should be stopped immediately, and workers should be removed from dangerous places until the latter are neutralized and the causes of gas appearance are identified.

5.3. If ammunition is detected, earthworks can be resumed only after checking the site and removing ammunition by sappers.



5.4. About each accident, occurrence of an accident, fire and the appearance of other hazards that threaten an accident or accident, inform the foreman of the site, organize first aid to the victims and send him to a medical institution, keep the situation at the workplace and the condition of the equipment as they were at the time of the incident, and do not start work until it is eliminated.

5.4. First aid.



**CHAPTER 7**  
**ENVIRONMENT PROTECTION**



## **7.1. Impact of construction works on soil and geological environment**

During construction, the ecosystem is destroyed and an artificial system for human life is created in its place. How acceptable it will be for a person who is part of the ecosystem, rather than the man-made environment, will depend on the art of the architect and builder not to upset the balance in the natural environment, ensuring its sustainability, harmoniously combining buildings and structures with natural ecosystem components. It has become a frequent phenomenon when a person in a place artificially created by architects and builders feels ecological discomfort.

Construction is a clear example of anthropogenic activity, which often has a serious negative impact not only on individual components of the environment and their conservation, but also on the resilience of ecosystems as a whole.

Today, one of the main tasks in construction is the accounting and analysis of all anthropogenic pressures on the environment and the assessment of actions on it to preserve and maintain ecological balance. There is a high level of air, water and soil pollution at construction sites, which ultimately leads to a decrease in biodiversity. This occurs at all stages: during the design and survey work, when arranging roads and quarries, directly when performing work on the construction site. Therefore, the issue of the impact of construction projects on the environment is extremely relevant.

All types of impact of construction on the environment can be classified according to the following environmental characteristics: removal from the environment and introduction into the environment. Sources of impact on ecosystems during construction are: new material objects located on the construction site; elements of the main and auxiliary technologies, the functioning of which is the cause of landscape change and environmental pollution; facilities whose life cycle is associated with construction or operation in the future. All these actions affect the resilience of ecosystems and reduce the quality of the environment, either directly or indirectly.

The main sources of pollution during construction works are: blasting, construction of ditches and trenches, deforestation and shrubs, damage to the soil layer and washing





away contaminants from the construction site, the formation of construction waste dumps and more.

Construction creates an additional environmental burden and causes deterioration of human health. Already built buildings also have a negative impact on the environment: the terrain changes, the vegetation changes, artificial plantings are replaced by artificial ones.

In addition to the negative effect on vegetation and soil, the consolidated object changes the conditions of insolation. Buildings shade the territory, the mode of evaporation of moisture changes.

It should also be noted that on construction sites during the preparation and actual construction accumulates a huge amount of construction debris, which creates an additional burden on urban ecosystems.

To date, there are two ways to dispose of construction waste:

- burial in specially designated landfills and dumps;
- complete processing with the help of special crushing equipment.

Until recently, the only option for recycling construction waste was the first option. But this method of disposal creates a lot of environmental problems. First of all - the alienation of land for construction landfills. In addition, the cost of receiving construction waste at landfills ranges from 6 to 10.0 dollars per 1 m<sup>3</sup>, excluding transportation costs. Therefore, we suggest the use of construction waste recycling as the most environmentally friendly way.

One of the main advantages of the mobile crushing plant is the possibility of its use directly on the site of construction waste. In this case, the mobile crushing and sorting complex is delivered to the construction site, where it immediately begins work. The most important factors of competitiveness of works on processing of construction waste on the mobile crushing installation are:

- low cost of this method of waste disposal compared to landfills;



- the possibility of processing waste at the place of their formation;
- obtaining cheap crushed stone in an environmentally friendly way;
- receipt of commodity scrap metal;
- solving numerous environmental problems.

Tasks and constructive program actions on environmental protection are an integral part of project work, starting from the general scheme of resettlement in the country, region, city and ending with projects of detailed planning of individual elements of the city, reconstruction of buildings and structures. This requires the urban planner to have a deep knowledge of the relationships between the objects being designed, their functional-spatial structure and the ecological situation that develops on the territory of these objects.

Thus, the ecological and economic aspects of construction and architecture become relevant and require a strategic vision and consideration of the ecological situation in all elements of the urban ecosystem. To prevent the destruction of the natural environment, to preserve biological diversity and to ensure the priority of ecology in all types of construction activities.

Construction begins with the alienation of land, clearing areas, cutting vegetation and earthworks. The area of land that can be used for agricultural purposes is limited and almost exhausted. During the development of construction sites, the fertile layer of soil and vegetation is destroyed, and the radical destruction of biogeocenoses takes place.

The upper fertile layer of soil is destroyed in areas that are used temporarily. Unfortunately, the ДБН requirements for soil conservation apply only to agricultural land (they are recultivated), because soil conservation increases the cost of construction. Thus, when landscaping, instead of the destroyed layer, soil is imported from the lands. As a result of earthworks, billions of cubic meters of soil are developed per year. Most of the developed soil goes to dumps. Development and transportation lead to air pollution by dust, toxic exhaust gases from construction, road machinery and transport. Dumps of



excavated soil change the natural landscape, morphology of the earth's surface, contribute to erosion and so on. All this creates unfavorable conditions for people's lives.

The environment is also affected by the building materials themselves (radioactivity, toxicity, dust formation) used in construction; construction machinery and transport; organization and culture of production (destruction of the soil layer by temporary access roads, toxic emissions from machinery and transport, noise, vibration, electromagnetic fields).

In addition, construction is accompanied by a large amount of construction waste. Together with garbage, more than 1 million tons of metal are lost annually in construction, 30% of glass, up to 15% of cement, up to 17% of bricks are turned into rubble and go to waste, and 40% of bricks have some damage. Up to 2 million tons of asphalt concrete containing up to 120,000 tons of bitumen, as well as sand, gravel and other materials are dumped in landfills per year [2]. Some wastes are taken to landfills located around the city, some are incinerated on construction sites or in landfills, some are buried, which has a negative impact on soil, air, and water bodies.

Work on the construction sites of various facilities has a negative impact on the environment. The degree of impact depends on the type of materials used, the technology of construction of the object, the technological equipment of construction production, the type and quality of machines, mechanisms and vehicles, types and power of engines, the organization of technological processes.

Construction machinery and equipment - the basis of any technological process of construction of buildings, structures, roads, airfields, etc. They perform work, interact with the environment and negatively affect the air, soil, biosphere, surface, groundwater and more.

The negative impacts of construction machinery on the environment include:

1. Emissions of exhaust gases, the components of which, depending on the condition, belong to different hazard classes.



2. In the construction zone there are sites for storage of materials, construction and track machines and equipment (CTMaE), sometimes fuels and lubricants.

3. In the course of work there is a leakage of fuels and lubricants due to malfunction of CTMaE, negligence, indiscipline and ignorance of workers.

4. When moving construction machinery, the soil layer is destroyed, which is practically not restored.

5. A layer of soil from construction sites, distribution strips, etc. is removed with streams of rain and melt water.

6. Parking lots, stops, platforms, exits near watercourses are arranged, polluted waters and garbage are dumped within water protection zones.

7. CTMaE have a physical impact on the environment, create vibration, noise, electromagnetic fields.

#### **7.1.1. Impact on land, soils**

Construction works are related to the impact on soils - soil disturbance during planning works, digging trenches, possible soil contamination by construction, household waste and garbage.

The total amount of waste generated during the works is:

- household: 1.2 m<sup>3</sup>;

- industrial: 0,168t.

During the operation of the facility, waste from lighting fixtures (LED lamps) and maintenance of four trucks (greasy rags, greasy sand, used batteries, filters, tires) will be generated.

The total amount of waste generated during the works is:

- household: 51.72 m<sup>3</sup>;



- industrial: 0.458 t.

Household waste is disposed of as it accumulates at the landfill. Industrial waste will be transferred to specialized enterprises for processing, disposal, utilization, according to existing agreements.

In order to prevent a negative impact on land resources, it is planned to equip workplaces and construction sites with containers for household and construction waste with subsequent removal to landfills.

Washing of machines and mechanisms is carried out in a specially allotted and equipped place.

In addition to the mandatory implementation of design decisions for soil protection, the construction organization must perform a number of measures:

- mandatory compliance with the boundaries of the territory allocated for construction;

- draining of fuels and lubricants in specially designated areas. Impact on soils under the conditions of this project during construction works is moderate, and during operation - absent.

The inspection of the area of the object, any recreational areas, lands of the nature reserve fund and other environmental purposes, monuments of architecture, culture and art were not found.

#### Impact on landscape and geological environment

The facility provides measures to eliminate soaking of soils by emergency leaks from utilities, process equipment and surface runoff:

- vertical planning of the construction site is solved in conjunction with the existing terrain;



- organization of surface water runoff with storm sewer installation with sewage treatment in local treatment facilities;

- installation of waterproof paving around the perimeter of the operator's building;

- laying of external and internal water communications with the exception of leaks from them;

During the implementation of protective measures, the state of the geological environment in the area of the new construction of industrial buildings and structures will not change significantly.

In compliance with the rules of operation, when performing all measures to prevent pollution, negative impacts on the geological environment are not expected.

### **7.1.2. Impact on landscape and geological environment**

The facility provides measures to eliminate soaking of soils by emergency leaks from utilities, process equipment and surface runoff:

- vertical planning of the construction site is solved in conjunction with the existing terrain;

- organization of surface water runoff with storm sewer installation with sewage treatment in local treatment facilities;

- installation of waterproof paving around the perimeter of the operator's building;

- laying of external and internal water communications with the exception of leaks from them;

During the implementation of protective measures, the state of the geological environment in the area of the new construction of industrial buildings and structures will not change significantly.

In compliance with the rules of operation, when performing all measures to prevent pollution, negative impacts on the geological environment are not expected.



## **7.2. Description of the provided measures aimed at preventing, avoiding, reducing, removing significant negative effects on the country for people**

The impact on the environment of the planned activity is possible only in case of serious violations of the technology of work, use of faulty equipment.

Violation of technological processes from the planned activities is not expected, as such a violation will also reduce productivity, and after detection will threaten the company with significant financial losses to eliminate environmental threats and to pay penalties.

Also, all construction works are planned to be carried out with serviceable equipment, which eliminates the possibility of soil or subsoil contamination with oil products. It is planned to refuel and repair equipment at local gas stations and service stations.

In the event of extreme weather conditions, the company will be required to enforce production restrictions in accordance with the law, which will minimize the impact of construction on environmental degradation.

### **7.2.1. Measures to minimize the impact on the geological environment**

The technology of construction works is developed taking into account the requirements of sanitary norms and rules, as well as safety rules.

### **7.2.2. Protection and rational use of soils and land resources**

Protective and resource-saving measures for protection against pollution and rational use of land resources are provided.

Protective measures include:

- collection of industrial waste separately by type and their transfer to specialized enterprises for disposal.

Resource-saving measures include:



- removal and storage of the soil layer and associated sedimentary rocks (up to a depth of 1.9 m) should be carried out without mixing, followed by use when backfilling the foundations after construction (with the location of the soil in the upper layer).

Vibration safety measures:

- selection of equipment and tools with the least vibration;
- measures to reduce vibration on the propagation paths from the excitation source (vibration-insulating foundations, vibration-insulating flanges on air ducts);
- selection of individual means of protection;
- for vibration-hazardous occupations, a rational mode of work is provided in accordance with Annex 8 of ДСТУ ГОСТ 12.1.012: 2008 [51], which establishes the duration of work and rest.

In accordance with the "Hygienic classification of labor (according to the indicators of harmfulness and danger of factors of the production environment, severity and intensity of the labor process") [21], working conditions for vibration safety belong to the second class, ie are within acceptable values.

### **7.2.3. Conclusion**

Therefore, from the above material I can conclude that the impact of construction on ecosystems at all stages is negative and ultimately leads to a decrease in biodiversity. The research has shown that the properties of soils that are exposed to construction are significantly different from the properties of the reference natural soils. The number of entomofauna within the influence of construction sites is significantly reduced compared to undisturbed areas. During the preparation and construction itself, a huge amount of construction waste accumulates on construction sites, which creates an additional burden on urban ecosystems. In order to reduce the anthropogenic load on the environment, I offer a method of processing construction waste at the sites of their formation using special crushing equipment.





## CONCLUSION

In master thesis is performed the analytical review of the literature with comparative analysis of calculation methods of metal prestressed load-bearing structures and selected the optimal method for roof truss calculation of industrial building. In proposed methodology of task calculation the determination of truss optimal parameters and geometrical characteristics of cross-section is carried with taking into account the influence of self-stressing.

In the work the calculation of roof truss prestressed by tendon is presented. The main purpose of pre-stressing is that the structure is pre-created stress-strain state, which is inverse in sign to what will take place during operation of the structure. Therefore, when the load is applied, the forces that were created in the process of pre-stressing are first overcome, and only then at the subsequent load (at 25 operations) there are inverse signs of force, in the process of growth of which comes one of the limit states of the structure.

Pre-stressing allows to apply concretes of the increased durability and accordingly to reduce own weight of designs.

During performing of diploma project the statical calculation was carried by means of program complex LIRA-SAPR after which results of statical calculation of the spatial frame during the process of which are determined forces  $M$ ,  $N$  for each load case.

At the estimation of engineering-geological conditions all given and calculated characteristics of soils are tabulated. Engineering-geological cross-section is developed. Conclusion about construction site is done in which it is said that soils of the base have layering strata. Existence at the depth 6.7 m of plastic sandy loam close to strongly compressed soils make worse soil conditions of the site.

The pile foundation with small loads may be laid within the limits of sandy loam with obligatory checking of the strength of underlying layer of sandy loam. Ground water are at the level 136 m and will not cause on the selection of foundation in this case.



Then was checked average pressure from calculated vertical forces under the foundation base. This pressure should be not more than calculated resistance of foundation soil. The maximum pressure under the foundation is not more than  $1.2R$  minimum. Then is done checking of weak underlaying layer of sandy loam. All conditions are satisfied that accepted dimensions of the foundation are retained without changes.

The next step was defining of final settlements of the foundation base by the method of layered summation. And the obtained settlements of the base 1.8 cm are less than limit value of mutual deformation of the base and structure 8 cm. Its mean that the requirements are satisfied.

In the chapter of occupational safety is performed analysis of harmful and dangerous production factors, there are proposed the measures to reduce the impact of harmful and dangerous production factors and occupational safety instruction.

In the chapter of environment protection the impact of construction works on soil and geological environment and measures aimed at preventing, avoiding, reducing, removing significant negative effects on the country for people are described.



## LITERATURE

1. Вимоги до оформлення документів: ДСТУ 4163-2003. - [Чинний з 2003-04-07]. – Державний комітет України з питань технічного регулювання та споживчої політики. 2003р. – (Національний стандарт України).
2. Правила виконання архітектурно – будівельних робочих креслень: ДСТУ Б А.2.4-7:2009. - [Чинний з 2009-01-24] – К.: Мінгеріонбуд України, 2011. – (Національний стандарт України).
3. Барашиков А.Я. Будівельні конструкції: підручник для студ. ВНЗ / А.Я. Барашиков, В.М. Колякова. – К.: Видавничий дім «Слово», 2011. – 256 с.
4. Городецкий А.С. Информационные технологии расчета и проектирования строительных конструкций / А.С. Городецкий, В.С. Шмуклер, А.В. Бондарев. – Киев-Харьков, 2003. – 889 с.
5. Верюжский Ю.В. Компьютерные технологии проектирования конструкций: учебно-методическое пособие / Ю.В. Верюжский, М.С. Барабаш, Ю.В. Гензерский. – К.: Книжкове видавництво НАУ, 2006. – 807 с.
6. Городецкий А.С. Компьютерные модели конструкций / А.С. Городецкий, И.Д. Еврезов. – К.: Изд-во «Факт», 2005. – 344 с.
7. Мельников Н.П. Проблема экономии стали в стальных конструкциях промышленных зданий, сооружений и мостов. Проектстальконструкция. Материалы по стальным конструкциям, №2, 1958.
8. Magnel G. Long prestressed steel truss erected for Belgien Hangar. «Civil engineering» №10, 1953.
9. Prestressed steel structures (Discussion) «The Structural Engineer» №7, 1951.
10. Клепиков С.Н. К расчету предварительно напряженных стальных ферм. «Известия высших учебных заведений. Строительство и архитектура». 1958.
11. Клепиков С.Н. Расчет предварительно напряженных стальных ферм. «Строительная промышленность» №7, 1958.
12. Сперанский Б.А. Стальные предварительно напряженные ферм производственных зданий и сооружений. «Промышленное строительство» №10, 1960.



13. Сперанский Б.А., Шавшукова Г.Н., Ольков Я.И. Способы предварительного напряжения стальных конструкций с высокопрочными напрягающими элементами. Проектирование и строительство промышленных зданий и сооружений. НИИПС АСИА СССР, Сб. №5. Гостройиздат, 1961.
14. Сперанский Б.А. Стальные фермы с отдельными предварительно напряженными стержнями. «Строительные конструкции промышленных зданий». Труды Уральского политехнического института им. С.М. Кирова. Свердловск, 1963.
15. Сперанский Б.А. Напрягающие элементы из стальных высокопрочных канатов для металлических предварительно напряженных конструкций. «Строительные конструкции промышленных зданий». Труды Уральского политехнического института им. С.М. Кирова. Свердловск, 1963.
16. Клименко Є.В. Технічна експлуатація і реконструкція будівель та споруд / Є.В. Клименко. – Полтава: ПолНТУ, 2004. – 280 с.
17. MacGregor, J.G. Reinforced Concrete: mechanics and design [Electronic resource] / James G. MacGregor, James K. Wight. – New Jersey: Upper Saddle River, 2005. – 1132 p. – Access mode: <http://www.twirpx.com/file/89289/>.
18. McCormac James C. Design of Reinforced Concrete / James C. McCormac, James K. Nelson. – Hoboken, NJ: John Wiley & Sons, 2006. – 725 p.
19. Методи визначення призмової міцності, модуля пружності і коефіцієнта Пуассона: ДСТУ Б В.2.7-217:2009. – [Чинний з 2009-09-01]. – К.: Мінрегіонбуд України, 2010. – 16 с. – (Національний стандарт України).
20. Шерешевский И.А. Конструирование промышленных зданий и сооружений. – М.: «Архитектура-С», 2005. – 186 с.
21. ДСТУ Б В.1.2-2:2006 Система забезпечення надійності та безпеки будівельних об'єктів. Прогини і переміщення. Вимоги проектування. – К.: МІНБУД України, 2006. – 14 с.
22. Samuelli F., Struct E. Structural prestressing. «The Structural Engineer» №2, v 39, 1955.



23. Szilard R. Design of prestressed composite steel structures. «Structural devision». November, 1959.
24. Ansari F. Stress-Strain Response and Failure Surface of High Strength Concrete Under Generalized State Stress. Innovations and Developments in Concrete Materials and Constructions. Proc. of Int. Conf. held at the Dundee, Scotland, UK, 9-11 September, 2002. – Thomas Telford, London.
25. СЕВ-FIP Model Code 1990. Design Code // Comite Euro-International du Beton. 1991, 437 p.
26. Будівельна біоніка. Закони розвитку технічних систем. Будівельні конструкції: навчальний посібник. – К.: Сталь, 2010.
27. ДБН В.1.2-2:2006 Система забезпечення надійності та безпеки будівельних об'єктів. Навантаження і впливи. Норми проектування. – К.: МІНБУД України, 2006.
28. ДБН В.2.6-198:2014. Сталеві конструкції. Норми проектування, виготовлення і монтажу.
29. Н.С. Примак “Расчет рамных конструкций одноэтажных промышленных зданий”.
30. А.А.Нилов, В.А.Пермяков, А.Я. Прицкер. Стальные конструкции производственных зданий. Справочник. Киев ”Будівельник” 1986.
31. Муханов К.К. Металлические конструкции. Учебник для вузов. Изд. 3-е, испр. и доп. М., Стройиздат, 1978.
32. ДБН А.3.2-2-2009 Система стандартів безпеки праці. Охорона праці і промислова безпека у будівництві. Основні положення (НПАОП 45.2-7.02-12)
33. ДСН 3.3.6.037-99 Санитарные нормы производственного шума, ультразвука и инфразвука.
34. ДСТУ 7239:2011 Система стандартів безпеки праці. Средства индивидуальной защиты. Общие требования и классификация.
35. ДБН В.1.2-14-2009. Загальні принципи забезпечення надійності та конструктивної безпеки будівель, споруд, будівельних конструкцій та основ. Норми проектування. – К.: Мінбуд України, 2009.



36. Гвоздев А.А. Дмитриев С.А. К расчету предварительно напряженных, обычных железобетонных и бетонных сечений по образованию трещин// Бетон и железобетон.— 1957.— №5.—С.17-22
37. ГОСТ 12004-81. Сталь арматурная. Методы испытания на растяжение. — Введ. 01.07.81.
38. Долидзе Д. Е. Испытание конструкций и сооружений.— М.: Высш. шк., 1975.— 252 с.
39. Л.Е. Линович. “Расчет и конструирование частей гражданских зданий”.
40. Зедгенидзе В.А. Экспериментальное исследование деформаций 159 изгибаемых железобетонных балок с преднапряженной арматурой при длительном действии нагрузок// Строительные конструкции: Сб. тр.— Вып. 29.— К.: Будівельник, 1977.—С 60-68
41. Пащенко А.М. Чисельний метод статичного розрахунку в імовірнісних задачах будівельних конструкцій// Збірник наукових праць (галузеве машинобудування, будівництво)/Полт. держ. техн. ун-т ім. Юрія Кондратюка.- Полтава: ПДТУ ім. Юрія Кондратюка, 1998.- Вип. 3.- С. 132-138.
42. Пащенко А.М. Метод скінченних елементів у розрахунку надійності статично невизначених металевих конструкцій// Збірник наукових праць (галузеве машинобудування, будівництво)/Полт. держ. техн. ун-т ім. Юрія Кондратюка.- Полтава: ПДТУ ім. Юрія Кондратюка, 2000.- Вип. 5.- С. 174-178.
43. Пічугін С.Ф., Трусів Г.М., Пащенко А.М. Чисельний метод розрахунку сталевих стиснуто-зігнутих елементів// Проблеми терії і практики будівництва: Зб. наук. ст.- Т.П.- Львів, 1997.- С.84-89.
44. Методи визначення призмової міцності, модуля пружності і коефіцієнта Пуассона: ДСТУ Б В.2.7-217:2009. – [Чинний з 2009-09-01]. – К.: Мінрегіонбуд України, 2010. – 16 с. – (Національний стандарт України).
45. ЛИРА 9.4. Примеры расчета и проектирования: учеб. Пособие / Ю.В. Гензерский, Ю.Д. Гераймович, А.Н. Куценко [и др.]. – К.: Факт, 2008. – 280 с.



46. Метод конечных элементов: теория и численная реализация. Программный комплекс «ЛИРА-Windows» / А.С. Городецкий, И.Д. Евзеров, Е.Б. Стрелец-Стрелецкий [и др.]. – К.: ФАКТ, 1997. – 138 с.
47. ДСТУ Б В.2.1-2-96 (ГОСТ 25100-95). Грунти. Класифікація. Державний комітет України у справах містобудування і архітектури. – К.: 1997.
48. Система забезпечення надійності та безпеки будівельних об'єктів. Загальні принципи забезпечення надійності та конструктивної безпеки будівель, споруд, будівельних конструкцій та основ: ДБН В.1.2- 14-2009 / Міністерство регіонального розвитку та будівництва України. – К.: Мінрегіонбуд України, 2009. – 37 с.
49. Павліков А.М. Розрахунок міцності нормальних перерізів балкових елементів за нелінійною деформаційною моделлю (на основі ДБН В.2.6-98:2009) : навчальний посібник / А.М. Павліков, О.В. Бойко. За ред. А.М. Павлікова. – Полтава: ПолтНТУ, 2012. – 85 с.
50. Hayhurst D.R., Brown P.R., Morrison C.J. The role of continuum damage in creep crack growth// Phil. Trans. Roy. Soc.- London, 1984.-№ 1516.-P. 131-158.
51. Шерешевский И.А. Конструирование промышленных зданий и сооружений. – М.: «Архитектура-С», 2005. – 186 с.
52. Двутавры стальные горячекатаные. Сортамент: Межгосударственный стандарт: ГОСТ 8239-89 [Введ. 1989-09-27]. – М.: Госкомитет по стандартам, 1989. – 4 с.
53. Металлические конструкции. Общий курс: учеб. для вузов / [Е.И. Беленя, В.А. Балдин, В.А. Балдин, Г.С. Ведеников и др.]; под. ред. Е.И. Беленя. – [6-е изд.]. – М.: Стройиздат, 1986. – 560 с.
54. Металеві конструкції: підруч. / [В.О. Пермяков, О.О. Нілов, О.В. Шимановский та ін.]; за заг. ред. В.О. Пермякова, О.В. Шимановського. К.: Сталь, 2008. – 812 с.
55. Лихтарников Я.М. Расчет стальных конструкций: справочное пособие / Я.М. Лихтарников, В.М.Клыков, Д.В. Ладыженский – К.: Будівельник, 1984. – 368 с.
56. Васильченко В.Т. Справочник конструктора металлических конструкций / В.Т. Васильченко, А.Н. Рутман, Е.П. Лукьяненко. – К.: Будівельник, 1980. – 288 с.



57. Нілов О.О. Металеві конструкції. Балки. Колони: навч. посіб. для студентів будівельних спеціальностей / О.О. Нілов. – К. : ІЗМН, 1997. – 232 с.
58. Безопасность труда в промышленности: справочник / К. Н. Ткачук [и др.] – К.: Техника, 1982. – 231 с.
59. Виноградов, Б. В. Безопасность труда и производственная санитария в машиностроении: сборник расчетов / Б. В. Виноградов. – М.: Машиностроение, 1963. – 264 с.
60. Інженерні рішення з охорони праці при розробці дипломних проектів інженерно-будівельних спеціальностей: навч. посіб. / за ред. В. В. Сафонова. – К.: Основа, 2000. – 336 с. – ISBN 966-7233-23-5.
61. Сивко, В. Й. Розрахунки з охорони праці / В. Й. Сивко. – Житомир: ЖІТІ, 2001. – 152 с. – ISBN 966-7570-90-8.
62. Средства защиты в машиностроении. Расчет и проектирование: справочник / Под ред. С. В. Белова. – М.: Машиностроение, 1989. – 368 с. – ISBN 5-217-00407-X.
63. Абовская С. Н. Новые пространственные сталежелезобетонные конструкции покрытия [Текст] / С. Н. Абовская.- Красноярск: Стройиздат, 1992. – 238 с.
64. Бельський Г.Е. Основные положения расчета стальных конструкций по стандарту СЭВ 3972-88 / Г.Е. Бельський // Строит. механика и расчет сооружений. – 1984. - № 4. – С. 8-18.
65. Клименко Ф.Є. Сталебетонные конструкции – эффективный вид строительных конструкций / Ф.Е. Клименко // Пром. Стр-во – 1979 – №6 – С. 13-16.
66. Костиков Л. М. История создания железобетона [Текст] / Л. М. Костиков // Материалы по истории строительной техники : сб. статей ; под. ред. Г. М. Людвига. – М.: Госстройиздат, 1962. – № 2. – С. 67-119.
67. Бліхарський З.Я. Реконструкція та підсилення будівель та споруд /З.Я. Бліхарський. – Львів: Вид-во Львівської політехніки, 2008. – 106 с.
68. Ференчик П. Предварительно напряженные стальные конструкции (перевод с немецкого) / П. Ференчик, М. Тохачек. – М.: Стройиздат, 1979. – 423 с.





69. Іваник Ю.І. Дослідження напружено-деформованого стану сталезалізобетонних попередньо напружених шпренгельних конструкцій в умовах постадійної роботи / Б.Г. Демчина, Ю.І. Іваник // Містобудування та територіальне планування: Наук.-техн. збірник. – К., КНУБА, 2016. – №61– С. 50-61. 73.
70. Іваник Ю.І. Експериментальні дослідження міцності й деформативності сталезалізобетонної статично невизначеної комбінованої шпренгельної конструкції / Б.Г. Демчина, Ю.І. Іваник, Б.Л. Назаревич // Nowoczesne rozwiązania materialowe i konstrukcyjne oraz problemy eksploatacyjne dotyczące budownictwa ogólnego i hydrotechnicznego: Monografia jubileuszowa. - Poznan, 2016.- p. 453-464.



**APPENDIX 1**  
**(Album of drawings)**

